



RHV090-150 Product Specifications

SINGLE PACKAGE HEAT PUMP ROOFTOP UNITS WITH X-VANE™ FAN TECHNOLOGY WITH OPTIONAL ELECTRIC HEAT (RHV) 7.5-12.5 TONS

The new 7.5 to 12.5 ton RHV090-150 packaged heat pump rooftop units (RTU) with X-Vane Fan Technology provides value added benefits never seen in this type of equipment before. New major design features include:

- Patented, industry's first efficient indoor fan system using Vane Axial fan with electronically commutated variable speed motor. As compared to today's typically used belt drive with forward curve fans, system provides reliable operation with:
 - 75% fewer moving parts
 - No fan belts, pulleys, shaft, and shaft bearings
 - 40% more efficient than traditional belt drive forward curve fans
 - Slow ramp up capability for better sound and comfort control
 - Internal protection from phase reversal and phase loss situations
 - High external static capability
 - Slide out blower assembly design
- Reliable 2 stage cooling with tandem scroll compressors technology, fully active evaporator coil, and mixed air temperature protection on all models
- New unit control board with intuitive indoor fan adjustment that uses simple dial and switch adjustments
- Reliable copper tube/aluminum fin condenser coil with 5/16 in. tubing to help reduce refrigerant charge and reduce weight versus prior designs

RHV units up to 12.5 tons are designed to fit on our roof curbs that were installed back to 1989, which makes replacement easy and eliminates the need for curb adapters, changing utility connections or supporting curb overhang situations.

2 speed Vane Axial indoor fan speed control helps deliver IEERs up to 15.0.

All models are capable of either vertical or horizontal airflow without dedicated models or field-installed kits. The 150 size models require a field installed supply air kit.

With "no-strip" screw collars, handled access panels, and more, the unit is easy to install, easy to maintain, and easy to use. Your new 7.5 to 12.5 ton RHV rooftop unit (RTU) provides optimum comfort and control from a packaged rooftop.

Installation ease

All RHV units are field-convertible to horizontal airflow, which makes it easy to adjust to unexpected jobsite complications. Lighter units make for easy replacement and aid in the structural approval process. Units have simple, fast plug-in connections to the standard integrated unit control board (UCB). Clearly labeled connections points to reduce installation time. Also, a large control box provides room to work.

Easy to maintain

With the new X-Vane Fan Vane Axial fan system and direct drive ECM motor, there is no longer a need to adjust or replace belts or pulleys as in past designs. This frees up maintenance, installation, and commissioning time.

Easy access handles provide quick and easy access to all normally serviced components. Our "no-strip" screw system has superior holding power and guides screws into position while preventing the screw from stripping the unit's metal.

Sloped, corrosion resistant composite drain pan sheds water; and won't rust.



RHV090-150

X-Vane™ Fan

Table of contents

	Page
Features/Benefits	1
Model number nomenclature	3
Capacity ratings	4
Physical data	6
Options and accessories	7
Base unit dimensions	11
Accessory dimensions	20
Performance data	22
Fan data	35
Electrical data	52
Typical wiring diagrams	70
Sequence of operation	77
Application data	79
Guide Specifications	80

Easy to use

The newly re-designed Unit Control Board puts all connections and troubleshooting points in one convenient place. Most low voltage connections are made to the same board and make it easy to access it. Setting up the fan is simple by an intuitive switch and rotary dial arrangement. RHV rooftops have high and low pressure switches, a new mixed air temperature switch, a filter drier, and 2-in. filters standard.

X-Vane Fan Technology

Direct drive X-Vane Fan Technology indoor fan system uses Vane Axial fan design and electrically commutated motors. This new Vane Axial design over past belt drive systems has 75% fewer moving parts, uses up to 40% less energy and has no fan belts, blower bearings and shaft. Full fan and motor assembly also slides out for easier maintenance and service.

Features/Benefits

Value-added features include:

- Single point electrical connections
- 7.5 to 12.5 ton models use fixed TXV refrigerant metering devices
- Scroll compressors with internal line-break overload protection
- Units come with an easy access tool-less filter door. Filter track tilts out for filter removal and replacement. All filters are the same size in each unit

Operating efficiency and flexibility

These RHV packaged rooftops meet the Department of Energy (DOE) 2023 efficiency standard, as well as the latest ASHRAE (American Society of Heating, Refrigerating, and Air-Conditioning Engineers) 90.1 and IECC¹ (International Energy Conservation Code) minimum IEER efficiency requirements.

Field convertible airflow

All RHV 7.5 to 12.5 ton units are field-convertible to horizontal airflow, which makes it easy to adjust to unexpected jobsite complications. 12.5 ton models require a simple supply duct cover kit to field convert from factory vertical to horizontal.

1. IECC is a registered trademark of the International Code Council, Inc.

Model number nomenclature

RHV090-150 Model Number Nomenclature

MODEL SERIES	R	H	V	0	9	0	L	0	2	A	0	A	A	A
Position Number	1	2	3	4	5	6	7	8	9	10	11	12	13	14
R = Rooftop														
H = Heat Pump with Electric Heat	Type													
V = R-410A with X-Vane™ Fan	Standard Efficiency													
090 = 90,000 BTUH = 7.5 Tons 102 = 102,000 BTUH = 8.5 Tons 120 = 120,000 BTUH = 10 Tons 150 = 150,000 BTUH = 12.5 Tons	Nominal Cooling Capacity													
H = 208/230-3-60 L = 460-3-60 S = 575-3-60	Voltage													
0 = No Heat (Field-Installed Only)	Electric Heating Capacity													
2 = Standard/Medium Static Direct Drive ECM with X-Vane Fan 3 = High Static Direct Drive ECM with X-Vane Fan 5 = Standard/Medium Static, Vertical Supply and Filter Status Switch 6 = High Static, Vertical Supply and Filter Status Switch	Motor Option (Indoor Fan)													
A = None B = Low Leak Economizer with Barometric Relief, OA Temperature Sensor E = Low Leak Economizer with Barometric Relief + CO ₂ Sensor, OA Temperature Sensor H = Low Leak Economizer with Barometric Relief and Enthalpy Sensor L = Economizer with Barometric Relief + CO ₂ Sensor, Enthalpy Sensor U = Ultra Low Leak Economizer with Barometric Relief, OA Temperature Sensor W = Ultra Low Leak Economizer with Barometric Relief, Enthalpy Sensor	Outdoor Air Options / Control													
0A = Standard 4B = Non Fused Disconnect Switch AA = Hinged Access Panels AT = Un-Powered Convenience Outlet BB = Powered Convenience Outlet BP = Return Air Smoke Detector BR = Supply Air Smoke Detector CJ = Condensate Overflow Switch	Factory-Installed Options													
A = Aluminum / Copper Cond and Evap Coil B = Precoat Alum/Copper Cond with Alum / Copper Evap C = E-Coated Alum/Copper Cond with Alum / Copper Evap D = E-Coated Alum / Copper Cond and Evap E = Copper/Copper Cond and Alum/Copper Evap F = Copper/Copper Cond and Evap	Condenser / Evaporator Coil Configuration													
A = Economizer controls for EconoMiZer® IV and others (except for factory-installed EconoMiZer X) B = Economizer controls for factory-installed EconoMiZer X	Economizer Control													

Capacity ratings

RHV AHRI Ratings

COOLING MODE							
UNIT	Cooling Stages	Nominal Capacity (tons)	Net Cooling Capacity (Btuh)	Total Power (kW)	EER	IEER with 2-Speed Indoor Fan Motor	AHRI Rating cfm
RHV090	2	7.5	86,000	7.7	11.20	15.0	3000
RHV102	2	8.5	96,000	8.7	11.00	15.0	3400
RHV120	2	10.0	118,000	10.7	11.00	15.0	4000
RHV150	2	12.5	144,000	13.6	10.60	15.0	5500

HEATING MODE					
UNIT	Heating, Low 17°F(-8°C) Ambient		Heating, High 47°F(8°C) Ambient		AHRI Rating cfm
	Net Capacity (Btuh)	COP	Net Capacity (Btuh)	COP	
RHV090	48,000	2.30	83,000	3.40	3000
RHV102	55,000	2.30	91,000	3.40	3400
RHV120	66,000	2.25	115,000	3.40	4000
RHV150	82,000	2.30	132,000	3.30	5500

NOTE(S):

1. Rated in accordance with AHRI Standards 340/360.
2. Rating are based on:
Cooling Standard: 80°F (27°C) db, 67°F (19°C) wb indoor air temperature and 95°F (35°C) db outdoor air temperature.
IEER Standard: A measure that expresses cooling part-load EER efficiency for commercial unitary air-conditioning and heat pump equipment on the basis of weighted operation at various load capacities.
3. All RHV units comply with ASHRAE 90.1-2019 (American Society of Heating, Refrigerating, and Air-Conditioning Engineers) and DOE-2023 (Department of Energy) Energy Standard for minimum IEER requirements.

LEGEND

- AHRI** — Air-Conditioning, Heating and Refrigeration Institute
COP — Coefficient of Performance
EER — Energy Efficiency Ratio
IEER — Integrated Energy Efficiency Ratio



Capacity ratings (cont)

Sound Rating Tables

RHV UNIT	COOLING STAGES	OUTDOOR SOUND (dB) AT 60Hz								
		A-Weighted	63	125	250	500	1000	2000	4000	8000
090	2	82	89.7	81.5	80.5	79.2	77.1	73.2	70.2	67.4
102	2	84	90.8	85.2	81.6	79.5	78.1	74.0	70.4	66.5
120	2	87	88.1	90.0	85.9	83.0	81.6	78.5	76.4	75.5
150	2	83	89.3	85.2	80.3	78.0	77.0	74.4	73.7	68.9

NOTES:

1. Outdoor sound data is measured in accordance with AHRI.
2. Measurements are expressed in terms of sound power. Do not compare these values to sound pressure values because sound pressure depends on specific environmental factors which normally do not match individual applications. Sound power values are independent of the environment and therefore more accurate.
3. A-weighted sound ratings filter out very high and very low frequencies, to better approximate the response of "average" human ear. A-weighted measurements for RHV units are taken in accordance with AHRI.

LEGEND

dB — Decibel

Minimum - Maximum Airflow Ratings (cfm) — Cooling Units and Accessory Electric Heat

UNIT	COOLING			ELECTRIC HEAT ^a	
	Minimum 2-Speed Airflow (Low Speed)	Minimum 2-Speed Airflow (High Speed)	Maximum Airflow cfm	Minimum Airflow cfm	Maximum Airflow cfm
RHV090	1350	2250	3750	2250	3750
RHV102	1275	2550	4250	2550	4250
RHV120	1800	3000	5000	3000	5000
RHV150	2250	3750	6250	3750	6250

NOTE(S):

- a. Electric heat modules and single point kits are available as field-installed accessories for RHV units.

Physical data

RHV090-150 Physical Data

RHV UNIT	RHV090	RHV102	RHV120	RHV150
NOMINAL TONS	7.5	8.5	10.0	12.5
BASE UNIT OPERATING WT (lb)^a	805	812	955	1250
REFRIGERATION SYSTEM				
No. Circuits/No. Compressors/Type	1/2/Scroll	1/2/Scroll	1/2/Scroll	1/2/Scroll
R-410A Charge (lb-oz)	17-8	21-2	21-5	24-14
Cooling Metering Device	TXV	TXV	TXV	TXV
Heating Metering Device	TXV	TXV	TXV	TXV
High-Pressure Trip/Reset (psig)	630/505	630/505	630/505	630/505
Loss of Charge Trip/Reset	27/44	27/44	27/44	27/44
EVAPORATOR COIL				
Material (Tube/Fin)	Cu/Al	Cu/Al	Cu/Al	Cu/Al
Coil Type	3/8 in. RTPF	3/8 in. RTPF	3/8 in. RTPF	3/8 in. RTPF
Rows/FPI	3/15	4/15	4/15	3/15
Total Face Area (ft²)	11.1	11.1	11.1	17.5
Condensate Drain Connection Size	3/4 in.	3/4 in.	3/4 in.	3/4 in.
CONDENSER COIL				
Material (Tube/Fin)	Cu/Al	Cu/Al	Cu/Al	Cu/Al
Coil Type	5/16 in. RTPF	5/16 in. RTPF	5/16 in. RTPF	5/16 in. RTPF
Rows/FPI	2/18	2/18	3/18	2/18
Total Face Area (ft²)	25.1	25.1	25.1	36.1
EVAPORATOR FAN AND MOTOR				
Standard/Medium Static 3 Phase				
Motor Qty / Drive Type	1 / Direct	1 / Direct	1 / Direct	1 / Direct
Max Cont bhp	2.4	2.4	2.4	3.0
Range (rpm)	250-2000	250-2000	250-2000	250-2200
Fan Qty / Type	1 / Vane Axial	1 / Vane Axial	1 / Vane Axial	1 / Vane Axial
Fan Diameter (in.)	22	22	22	22
High Static 3 Phase				
Motor Qty / Drive Type	1 / Direct	1 / Direct	1 / Direct	1 / Direct
Max Cont bhp	3	3	5	5
Range (rpm)	250-2200	250-2200	250-2200	250-2200
Fan Qty / Type	1 / Vane Axial	1 / Vane Axial	1 / Vane Axial	1 / Vane Axial
Fan Diameter (in.)	22	22	22	22
CONDENSER FAN AND MOTOR				
Qty / Motor Drive Type	2 / Direct	2 / Direct	1 / Direct	3 / Direct
Motor hp / rpm	1/4 / 1100	1/4 / 1100	1 / Multiple Speeds	1/4 / 1100
Fan Diameter (in.)	22	22	30	22
FILTERS				
RA Filter Qty / Size (in.)	4 / 20x20x2	4 / 20x20x2	4 / 20x20x2	6 / 18x24x2
OA Inlet Screen Qty / Size (in.)	1 / 20x24x1	1 / 20x24x1	1 / 20x24x1	Vertical: 2 / 24x27x1 Horizontal: 1 / 30x39x1

NOTE(S):

a. Base unit operating weight does not include weight of options.

LEGEND

bhp — Brake Horsepower
FPI — Fins Per Inch
OA — Outdoor Air
RA — Return Air

Options and accessories

ITEM	OPTION ^a	ACCESSORY ^b
ELECTRIC HEAT		
Electric Resistance Heaters		X
Single Point Kits		X
CABINET		
Hinged Access Panels	X	
UV-C Ultraviolet Lamp		X
4 in. Filter Rack (filters not included)		X
Louvered Hail Guard		X
COIL OPTIONS		
Cu/Cu Indoor and/or Outdoor Coils	X	
Pre-Coated Outdoor Coils	X	
Premium, E-Coated Outdoor Coils	X	
CONTROLS		
Thermostats, Temperature Sensors, and Subbases		X
Smoke Detector (supply and/or return air)		X
Horn Strobe Annunciator ^c		X
Time Guard II Compressor Delay Control Circuit		X
Phase Monitor	X	X
ECONOMIZERS AND OUTDOOR AIR DAMPERS		
EconoMi\$er [®] IV for Electro-mechanical Controls — Non-FDD (Standard air leak damper models) ^d		X
EconoMi\$er X for Electro-mechanical Controls, complies with FDD (Low and Ultra Low Leak damper models) ^d	X	X
Motorized Two-Position Outdoor-Air Damper		X
Manual Outdoor-Air Damper (25% and 50%)		X
Barometric Relief ^e	X	X
Power Exhaust — Prop Design		X
Condensate Overflow Switch	X	X
ECONOMIZER SENSORS AND IAQ DEVICES		
Single Dry Bulb Temperature Sensors ^f	X	X
Differential Dry Bulb Temperature Sensors ^f		X
Single Enthalpy Sensors ^f	X	X
Differential Enthalpy Sensors ^f		X
CO ₂ Sensor (wall, duct, or unit mounted) ^f	X	X

ITEM	OPTION ^a	ACCESSORY ^b
INDOOR MOTOR AND DRIVE		
Multiple Motor and Drive Packages	X	
LOW AMBIENT CONTROLS		
Winter Start Kits ^g		X
Low Ambient Controller to 0°F (-18°C) ^g		X
POWER OPTIONS		
Convenience Outlet (powered)	X	
Convenience Outlet (unpowered)	X	
Convenience Outlet, 20 amp (unpowered)		X
Non-fused Disconnect ^h	X	
ROOF CURBS		
Roof Curb 14 in. (356 mm)		X
Roof Curb 24 in. (610 mm)		X

NOTE(S):

- a. Factory-installed option.
- b. Field-installed accessory.
- c. Requires a field-supplied 24V transformer for each application.
- d. FDD (Fault Detection and Diagnostic) capability per California Title 24 section 120.2.
- e. Included with economizer.
- f. Sensors used to optimize economizer performance.
- g. See application data for assistance.
- h. Non-fused disconnect switch cannot be used when unit FLA electrical rating exceeds –
 - Sizes 090-120: 80 amps, all voltages.
 - Size 150: 100 amps, all voltages.

Options and accessories (cont)

Factory-installed options

Economizer (dry-bulb or enthalpy)

Economizers save money. They bring in fresh, outside air for ventilation; and provide cool, outside air to cool your building. This is the preferred method of low-ambient cooling. When coupled to CO₂ sensors, economizers can provide even more savings by coupling the ventilation air to only that amount required.

Economizers are available, installed and tested by the factory, with either enthalpy or dry-bulb temperature inputs. Additional sensors are available as accessories to optimize the economizers. Economizers include a powered exhaust system to help equalize building pressures.

Economizers can be factory-installed or easily field-installed.

Unit mounted CO₂ sensor

The CO₂ sensor works with the economizer to intake only the correct amount of outside air for ventilation. As occupants fill your building, the CO₂ sensor detects their presence through increasing CO₂ levels, and opens the economizer appropriately. When the occupants leave, the CO₂ levels decrease, and the sensor appropriately closes the economizer. This intelligent control of the ventilation air, called demand controlled ventilation (DCV), reduces the overall load on the rooftop, saving money. It is also available as a field-installed accessory.

Smoke detector (supply and/or return air)

Smoke detectors make your application safer and your job easier. Our smoke detectors immediately shut down the rooftop unit when smoke is detected. They are available, installed by the factory, for supply air, return air, or both.

Thru-the-base connections

Thru-the-base connections, available as a factory option, are necessary to ensure proper connection and seal when routing wire and piping through the rooftop's base-pan and curb. These couplings eliminate roof penetration and should be considered for gas lines, main power lines, as well as control power.

Hinged access panels

Allows access to unit's major components with specifically designed hinged access panels. Panels are filter, control box access, and indoor fan motor access.

Cu/Cu (indoor) coils

Copper fins and copper tubes are mechanically bonded to copper tubes and copper tube sheets. A polymer strip prevents coil assembly from contacting the sheet metal coil pan to minimize potential for galvanic corrosion between coil and pan.

E-coated (outdoor and indoor) coils

A flexible epoxy polymer coating uniformly applied to all coil surface areas without material bridging between fins. Coating process shall ensure complete coil encapsulation of tubes, fins and headers.

Pre-coated outdoor coils

A durable epoxy-phenolic coating to provide protection in mildly corrosive coastal environments. The coating minimizes galvanic action between dissimilar metals. Coating is applied to the aluminum fin stock prior to the fin stamping process to create an inert barrier between the aluminum fin and copper tube.

Condenser coil hail guard

Sleek, louvered panels protect the condenser coil from hail damage, foreign objects, and incidental contact.

Convenience outlet (powered or un-powered)

Reduce service and/or installation costs by including a convenience outlet in your specification. We will install this service feature at our factory. Provides a convenient, 15 amp, 115v GFCI receptacle with "Wet in Use" cover. The "powered" option allows the installer to power the outlet from the line side of the disconnect or load side as required by code. The "unpowered" option is to be powered from a separate 115/120v power source.

The unpowered convenience outlet is available as a 15 amp factory-installed option or a 20 amp field-installed accessory.

Non-fused disconnect

This OSHA-compliant, factory-installed, safety switch allows a service technician to locally secure power to the rooftop. When selecting a factory-installed non-fused disconnect, note they are sized for the unit as ordered from the factory. The sizing of these do not accommodate field-installed items such as power exhaust devices, etc. If field installing electric heat with factory-installed non-fused disconnect switch, a single point kit may or may not be required.

Condensate overflow switch

This sensor and related controller monitors the condensate level in the drain pan and shuts down compression operation when overflow conditions occur. It includes:

- Indicator light – solid red (more than 10 seconds on water contact – compressors disabled), blinking red (sensor disconnected)
- 10-second delay to break – eliminates nuisance trips from splashing or waves in pan (sensor needs 10 seconds of constant water contact before tripping)
- Disables the compressors operation when condensate plug is detected, but still allows fans to run for economizer.

Options and accessories (cont)

Field-installed accessories

Filter maintenance indicator

When the optional factory-installed filter maintenance indicator is used, a factory-installed differential pressure switch measures pressure drop across the outside air filter and activates a field-supplied dry contact indicator when the pressure differential exceeds the adjustable switch setpoint.

Condenser coil hail guard

Sleek, louvered panels protect the condenser coil from hail damage, foreign objects, and incidental contact. This can be purchased as a factory-installed option or as a field-installed accessory.

Differential enthalpy sensor

The differential enthalpy sensor is comprised of an outdoor and return air enthalpy sensors to provide differential enthalpy control. The sensor allows the unit to determine if outside air is suitable for free cooling.

Wall or duct mounted CO₂ sensor

The IAQ sensor shall be available in duct or wall mount. The sensor provides demand ventilation indoor air quality (IAQ) control.

4 in. filter rack kit

The 4 in. filter rack accessory kit is designed to hold 4 in. MERV-8 or MERV-13 filters. Filters not included in kit.

UV-C ultraviolet lamp kit

High-output, low temperature ultraviolet lamp. Accessory kit includes lamp, interlock switch, mounting brackets, necessary wires, wire ties, screws and labels to field install kit in unit return air plenum. Separate dedicated 115v power source required. See appropriate installation instructions.

Phase monitor protection

The Phase Monitor Control will monitor the sequence of 3 phase electrical system to provide a phase reversal protection; and monitor the 3 phase voltage inputs to provide a phase loss protection for the 3 phase device. It will work on either a Delta or Wye power connection.

Winter start kit

The winter start kit extends the low ambient limit of your rooftop to 25°F (−4°C). The kit bypasses the low pressure switch, preventing nuisance tripping of the low pressure switch. Other low ambient precautions may still be prudent.

Low ambient controller

The low ambient controller is a head pressure controller kit that is designed to maintain the unit's condenser head pressure during periods of low ambient cooling operation. This device should be used as an alternative to

economizer free cooling when economizer usage is either not appropriate or desired. The low ambient controller will either cycle the outdoor fan motors or operate them at reduced speed to maintain the unit operation, depending on the model. This controller allows cooling operation down to 0°F (−18°C) ambient conditions.

NOTE: 0°F (−18°C) is standard on size 120 models.

Roof curb (14 in./356 mm or 24 in./610 mm)

Full perimeter roof curb with exhaust capability provides separate air streams for energy recovery from the exhaust air without supply air contamination.

Filter status indicator accessory

Monitors static pressure across supply and exhaust filters and provides indication when filters become clogged.

Power exhaust

Superior internal building pressure control. This field-installed accessory may eliminate the need for costly, external pressure control fans.

Manual OA damper

Manual outdoor air dampers are an economical way to bring in ventilation air. The dampers are available in 25% and 50% versions.

NOTE: See application tip "ROOFTOP-18-01" prior to use of this damper on 090-150 size models.

Motorized Two-Position damper

The two-position, motorized outdoor air damper admits up to 100% outside air. Using reliable, gear-driven technology, the two-position damper opens to allow ventilation air and closes when the rooftop stops, stopping unwanted infiltration.

NOTE: See application tip "ROOFTOP-18-01" prior to use of this damper on 090-150 size models.

Electric heaters

We offer a full-line of field-installed accessory heaters. The heaters are very easy to use, install and are all pre-engineered and certified.

Time Guard II control circuit

This accessory protects your compressor by preventing short-cycling in the event of some other failure, prevents the compressor from restarting for 30 seconds after stopping. Not required with authorized commercial thermostats.

Disconnect switch bracket

Provides a pre-engineered and sized mounting bracket for applications requiring a unit mounted fused and non-fused disconnect of greater than 100 amps. Bracket assures that no damage will occur to coils when mounting with screws and other fasteners (150 size only).

Options and accessories (cont)

Options and Accessory Weights^a

OPTION / ACCESSORY NAME	RHV UNIT WEIGHT							
	090		102		120		150	
	lb	kg	lb	kg	lb	kg	lb	kg
Power Exhaust — Vertical	75	34	75	34	75	34	85	39
Power Exhaust — Horizontal	30	14	30	14	30	14	75	34
EconoMi\$er® (X or IV)	55	25	55	25	55	25	85	39
Two-Position Damper	58	26	58	26	58	26	65	29
Manual Damper	18	8	18	8	18	8	25	11
Hail Guard (louvered)	17	8	17	8	17	8	17	8
Cu/Cu Condenser Coil	85	39	85	39	100	46	150	68
Cu/Cu Evaporator Coil	50	23	100	46	100	46	100	46
Roof Curb (14 in. curb)	143	65	143	65	143	65	180	82
Roof Curb (24 in. curb)	245	112	245	112	245	112	255	116
CO ₂ Sensor	2	1	2	1	2	1	2	1
Optional Indoor Motor ^b	30	14	30	14	30	14	0	0
Low Ambient Controller	9	4	9	4	N/A	N/A	9	4
Winter Start Kit	5	2	5	2	5	2	5	2
Return Air Smoke Detector	7	3	7	3	7	3	7	3
Supply Air Smoke Detector	7	3	7	3	7	3	7	3
Fan Filter Switch	2	1	2	1	2	1	2	1
Non-Fused Disconnect	15	7	15	7	15	7	15	7
Powered Convenience Outlet	36	16	36	16	36	16	36	16
Unpowered Convenience Outlet	4	2	4	2	4	2	4	2
Enthalpy Sensor	2	1	2	1	2	1	2	1
Differential Enthalpy Sensor	3	1	3	1	3	1	3	1

NOTE(S):

- a. Where multiple variations are available, the heaviest combination is listed.
- b. Add the Optional Indoor Motor weight to the weight of the base unit.

RHV090-102 Base Unit Dimensions

- NOTES:
1. DIMENSIONS ARE IN INCHES. DIMENSIONS IN [] ARE IN MILLIMETERS.
 2. CENTER OF GRAVITY
 3. DIRECTION OF AIR FLOW
 4. ALL VIEW DRAWN USING 3RD ANGLE

UNIT	OUTDOOR COIL TYPE	J	K	H
RHV090	RTPF	49 3/8 [1253]	36 3/8 [925]	15 7/8 [403]
RHV102	RTPF	49 3/8 [1253]	36 3/8 [925]	15 7/8 [403]

RTPF - ROUND TUBE, PLATE FIN (COPPER/ALUM)



THIS DOCUMENT IS THE PROPERTY OF CARRIER CORPORATION AND IS DELIVERED UPON THE EXPRESS CONDITION THAT THE CONTENTS WILL NOT BE DISCLOSED OR USED WITHOUT CARRIER CORPORATION'S WRITTEN CONSENT.

SUBMISSION OF THESE DRAWINGS OR DOCUMENTS DOES NOT CONSTITUTE PART PERFORMANCE OR ACCEPTANCE OF CONTRACT.

CONNECTION SIZES	
A	1 3/8" [35] DIA FIELD POWER SUPPLY HOLE
B	2 1/2" [64] DIA POWER SUPPLY KNOCKOUT
C	1 3/4" [51] DIA GAUGE ACCESS PLUG
D	7/8" [22] DIA FIELD CONTROL WIRING HOLE
E	3/4"-14 NPT CONDENSATE DRAIN
G	2" [51] DIA POWER SUPPLY KNOCK-OUT

THRU-THE-BASE CHART (FIELD INST)
THESE HOLES REQUIRED FOR USE WITH ACCY KITS: CRBTMPWR002A01

	THREADED CONDUIT SIZE	WIRE USE	REQ'D HOLE SIZES (MAX.)
W	1/2"	ACC.	7/8" [22.2]
X	1/2"	24V	7/8" [22.2]
Y	1 1/4" (002)	POWER	1 3/4" [44.4]

THRU-THE-BASE CHART (FIOP)
FOR "THRU-THE-BASEPAN" FACTORY OPTION, FITTINGS FOR ONLY X & Y ARE PROVIDED. (1) 1/2" & (1) 1 1/4" ELECTRICAL FITTINGS.

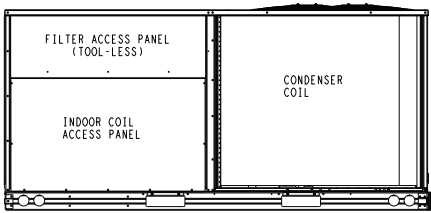

BACK

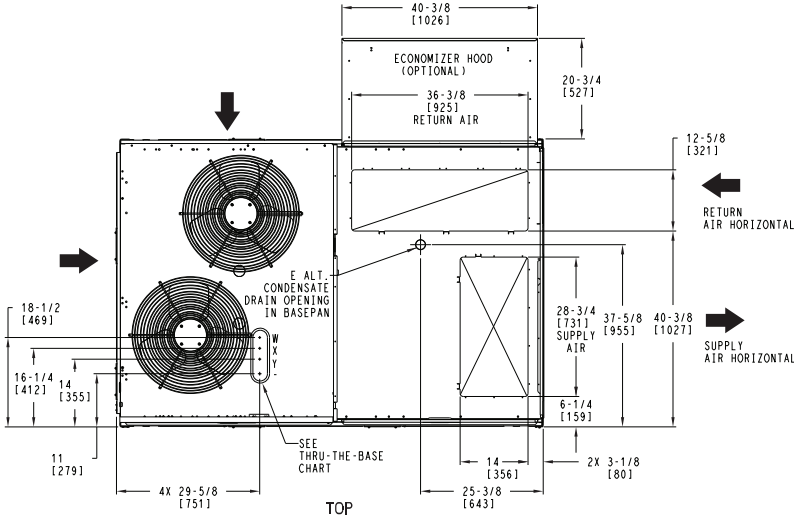

TOP

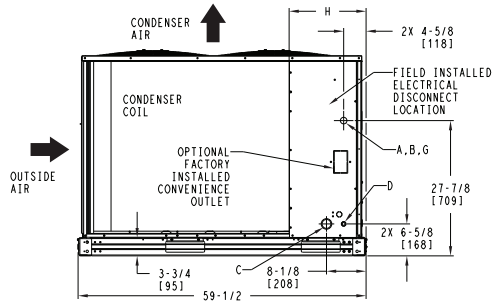

LEFT

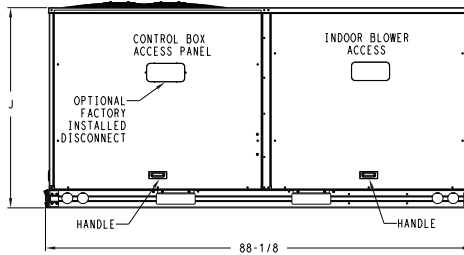

FRONT

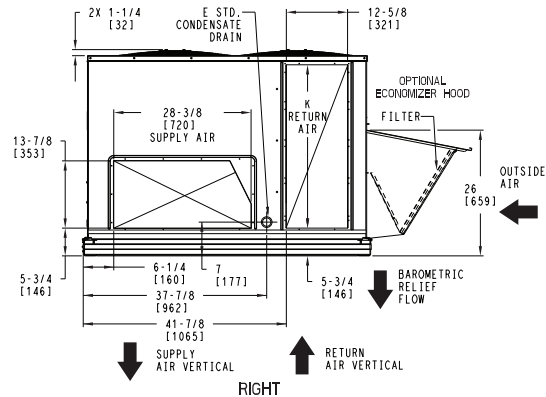

RIGHT

RHV090-102 Base Unit Dimensions (cont)

UNIT	OUTDOOR COIL TYPE	STD. UNIT WEIGHT ***		CORNER WEIGHT (A)		CORNER WEIGHT (B)		CORNER WEIGHT (C)		CORNER WEIGHT (D)		C.G.		
		LBS.	KG.	LBS.	KG.	LBS.	KG.	LBS.	KG.	LBS.	KG.	X	Y	Z
RHV090	RTPF	805	365	163	74	209	95	243	110	190	86	49 1/2 [1257]	32 [813]	19 1/8 [486]
RHV102	RTPF	812	368	164	75	211	96	245	111	191	87	49 1/2 [1257]	32 [813]	19 1/8 [486]

RTPF - ROUND TUBE, PLATE FIN (COPPER/ALUM)



THIS DOCUMENT IS THE PROPERTY OF CARRIER CORPORATION AND IS DELIVERED UPON THE EXPRESS CONDITION THAT THE CONTENTS WILL NOT BE DISCLOSED OR USED WITHOUT CARRIER CORPORATION'S WRITTEN CONSENT.

SUBMISSION OF THESE DRAWINGS OR DOCUMENTS DOES NOT CONSTITUTE PART PERFORMANCE OR ACCEPTANCE OF CONTRACT.

*** STANDARD UNIT WEIGHT IS WITHOUT ELECTRIC HEAT AND WITHOUT PACKAGING. FOR OTHER OPTIONS AND ACCESSORIES, REFER TO THE PRODUCT DATA CATALOG.

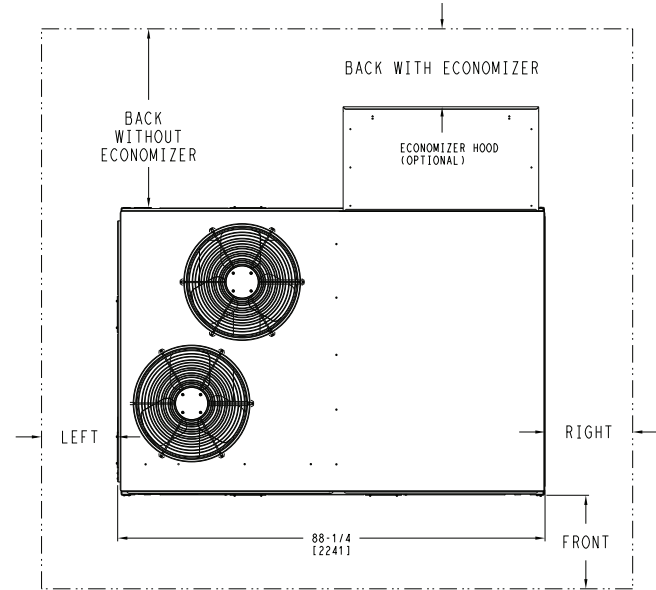
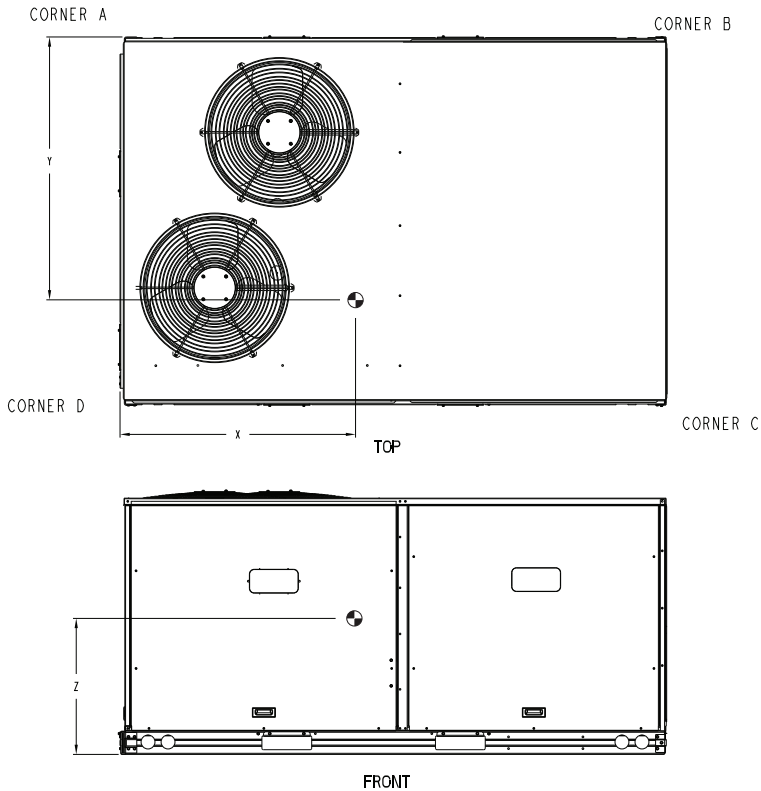

NOTE:

1. FOR ALL MINIMUM CLEARANCES LOCAL CODES OR JURISDICTIONS MAY PREVAIL.

SURFACE	CLEARANCE	
	SERVICE WITH: CONDUCTIVE BARRIER	SERVICE WITH: NONCONDUCTIVE BARRIER
FRONT	48 [1219mm]	36 [914mm]
LEFT	48 [1219mm]	42 [1067mm]
BACK W/O ECON	48 [1219mm]	42 [1067mm]
BACK W/ECON	36 [914mm]	36 [914mm]
RIGHT	36 [914mm]	36 [914mm]
TOP	72 [1829mm]	72 [1829mm]

RHV090-102 Base Unit Dimensions (cont)

IGP THIS DOCUMENT IS THE PROPERTY OF CARRIER CORPORATION AND IS DELIVERED UPON THE EXPRESS CONDITION THAT THE CONTENTS WILL NOT BE DISCLOSED OR USED WITHOUT CARRIER CORPORATION'S WRITTEN CONSENT. SUBMISSION OF THESE DRAWINGS OR DOCUMENTS DOES NOT CONSTITUTE PART PERFORMANCE OR ACCEPTANCE OF CONTRACT.

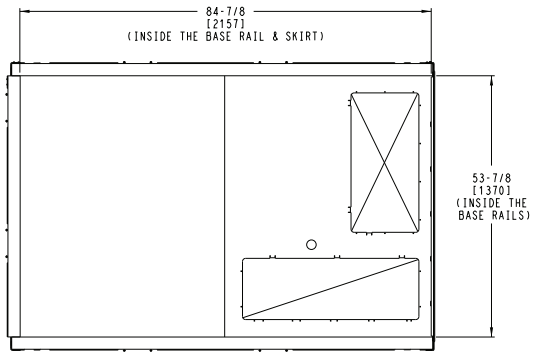
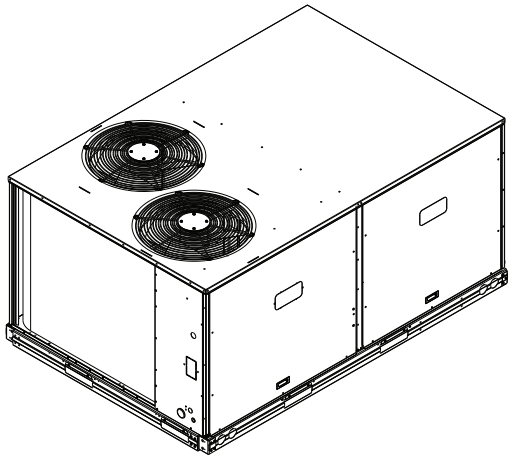

INSIDE BASERAIL DIMENSIONS
BOTTOM

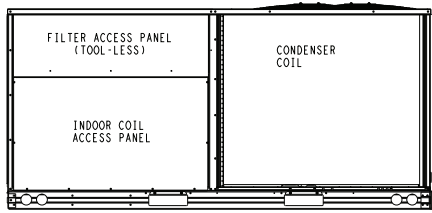
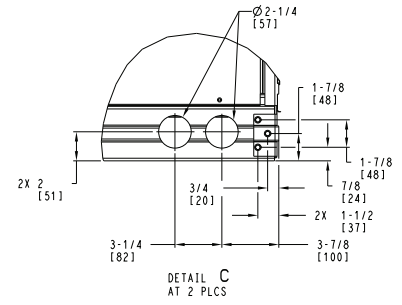
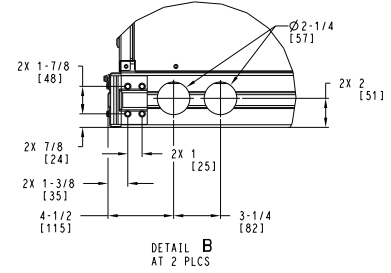

BACK

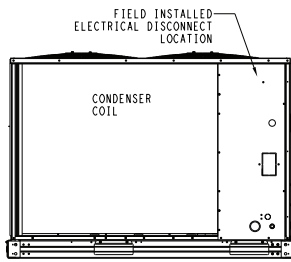

LEFT

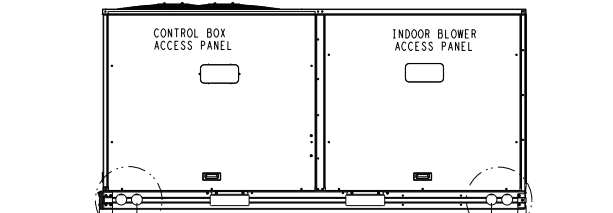

FRONT

RHV120 Base Unit Dimensions

- NOTES:
1. DIMENSIONS ARE IN INCHES, DIMENSIONS IN [] ARE IN MILLIMETERS.
 2. CENTER OF GRAVITY
 3. DIRECTION OF AIR FLOW
 4. ALL VIEW DRAWN USING 3RD ANGLE

UNIT	OUTDOOR COIL TYPE	H
RHV120	RTPF	15 7/8 [403]
RTPF - ROUND TUBE, PLATE FIN (COPPER/ALUM)		

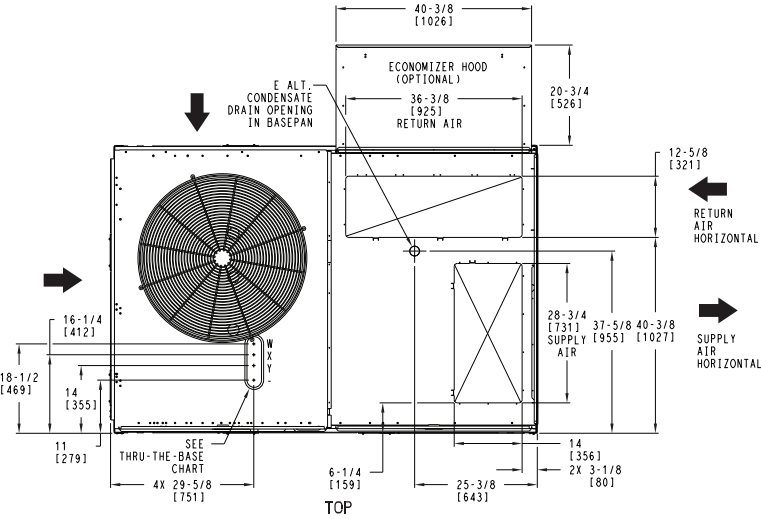
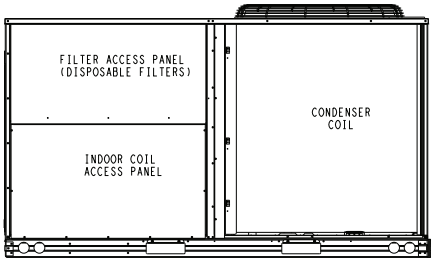

CONNECTION SIZES	
A	1 3/8" [35] DIA FIELD POWER SUPPLY HOLE
B	2 1/2" [64] DIA POWER SUPPLY KNOCKOUT
C	1 3/4" [51] DIA GAUGE ACCESS PLUG
D	7/8" [22] DIA FIELD CONTROL WIRING HOLE
E	3/4"-14 NPT CONDENSATE DRAIN
G	2" [51] DIA POWER SUPPLY KNOCK-OUT

THRU-THE-BASE CHART THESE HOLES REQUIRED FOR USE CRBTMPW002A01			
	THREADED CONDUIT SIZE	WIRE USE	REQ'D HOLE SIZES (MAX.)
W	1/2"	ACC.	7/8" [22.2]
X	1/2"	24V	7/8" [22.2]
Y	1 1/4" [002]	POWER	1 3/4" [44.4]

FOR "THRU-THE-BASEPAN" FACTORY OPTION, FITTINGS FOR ONLY X & Y ARE PROVIDED

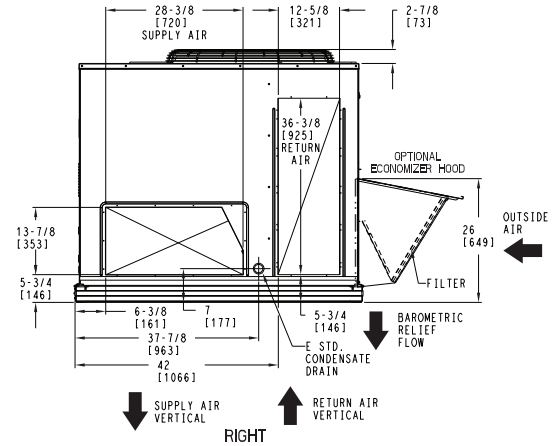
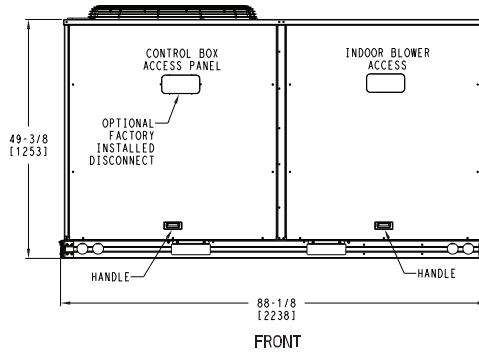
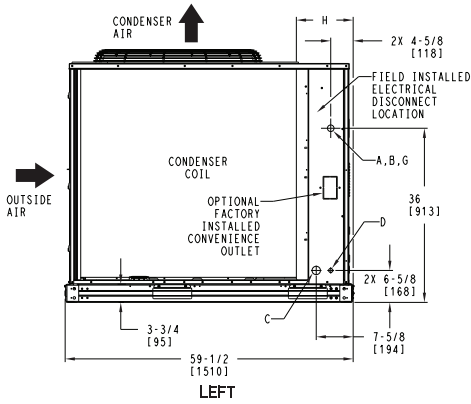

RHV120 Base Unit Dimensions (cont)

UNIT	OUTDOOR COIL TYPE	STD. UNIT WEIGHT***		CORNER WEIGHT (A)		CORNER WEIGHT (B)		CORNER WEIGHT (C)		CORNER WEIGHT (D)		C.G.		
		LBS.	KG.	LBS.	KG.	LBS.	KG.	LBS.	KG.	LBS.	KG.	X	Y	Z
RHV120	RTPF	955	433	190	86	243	110	293	133	229	104	49 1/2 [1257]	32 1/2 [826]	19 1/8 [486]

RTPF - ROUND TUBE, PLATE FIN (COPPER/ALUM)

*** STANDARD UNIT WEIGHT IS WITHOUT ELECTRIC HEAT AND WITHOUT PACKAGING. FOR OTHER OPTIONS AND ACCESSORIES, REFER TO THE PRODUCT DATA CATALOG.



THIS DOCUMENT IS THE PROPERTY OF CARRIER CORPORATION AND IS DELIVERED UPON THE EXPRESS CONDITION THAT THE CONTENTS WILL NOT BE DISCLOSED OR USED WITHOUT CARRIER CORPORATION'S WRITTEN CONSENT.

SUBMISSION OF THESE DRAWINGS OR DOCUMENTS DOES NOT CONSTITUTE PART PERFORMANCE OR ACCEPTANCE OF CONTRACT.

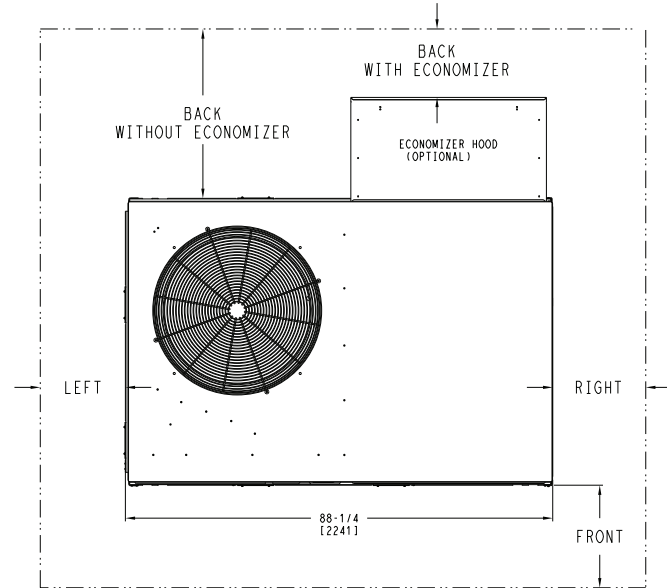
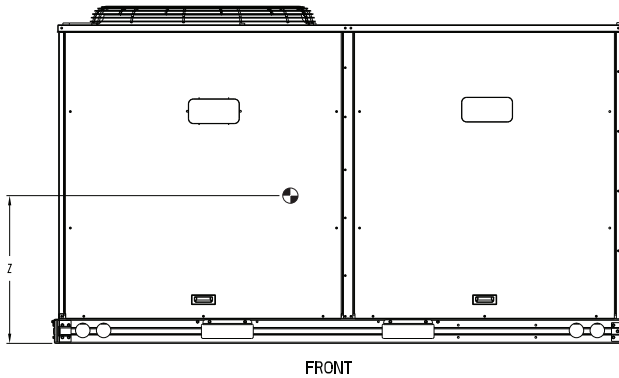
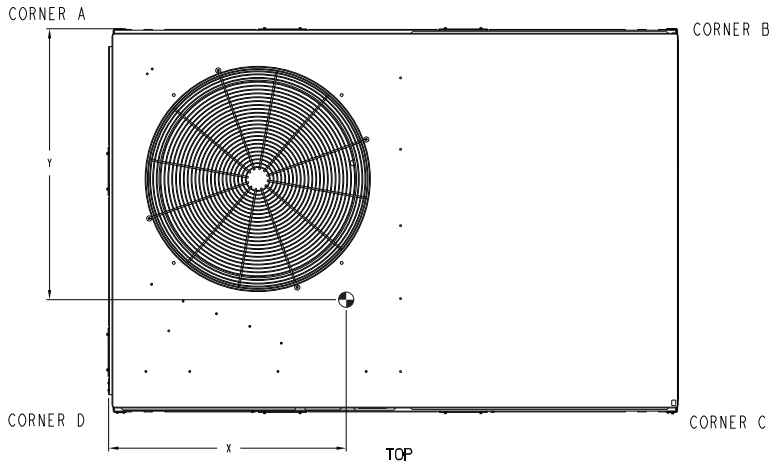

NOTE:

1. FOR ALL MINIMUM CLEARANCES LOCAL CODES OR JURISDICTIONS MAY PREVAIL.

SURFACE	CLEARANCE	
	SERVICE WITH: CONDUCTIVE BARRIER	SERVICE WITH: NONCONDUCTIVE BARRIER
FRONT	48 [1219mm]	36 [914mm]
LEFT	48 [1219mm]	42 [1067mm]
BACK W/O ECON	48 [1219mm]	42 [1067mm]
BACK W/ECON	36 [914mm]	36 [914mm]
RIGHT	36 [914mm]	36 [914mm]
TOP	72 [1829mm]	72 [1829mm]

RHV120 Base Unit Dimensions (cont)



THIS DOCUMENT IS THE PROPERTY OF CARRIER CORPORATION AND IS DELIVERED UPON THE EXPRESS CONDITION THAT THE CONTENTS WILL NOT BE DISCLOSED OR USED WITHOUT CARRIER CORPORATION'S WRITTEN CONSENT.

SUBMISSION OF THESE DRAWINGS OR DOCUMENTS DOES NOT CONSTITUTE PART PERFORMANCE OR ACCEPTANCE OF CONTRACT.

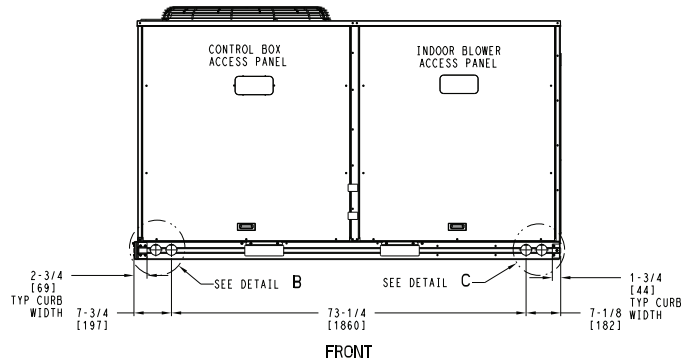
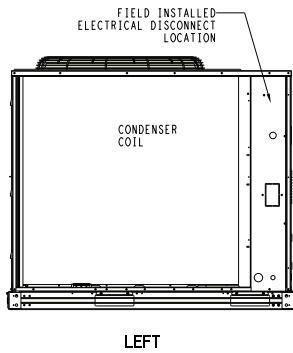
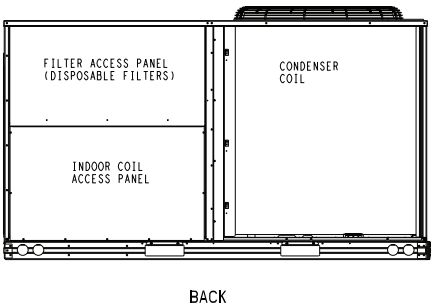
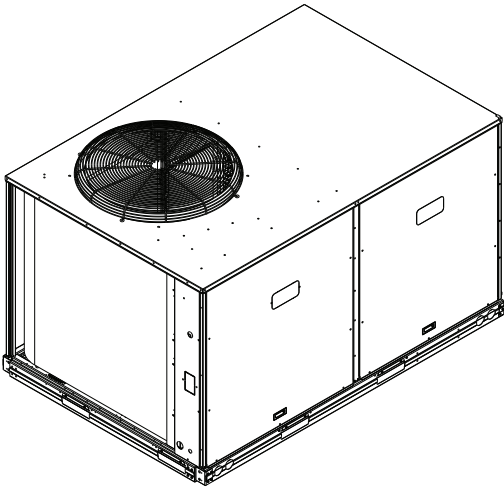
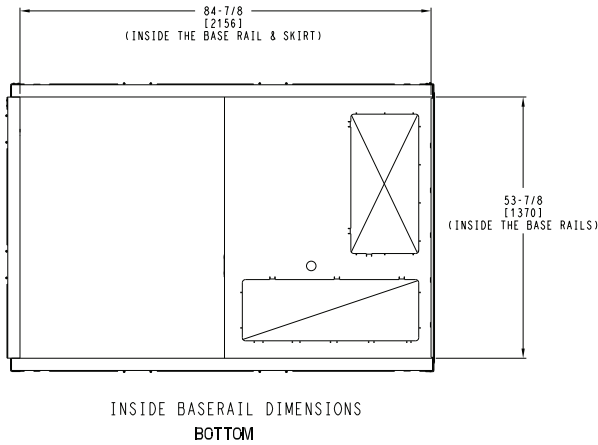
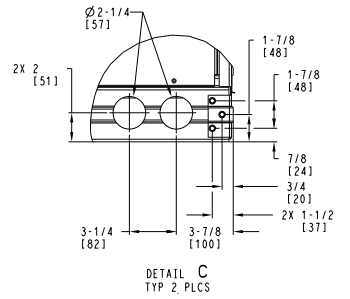
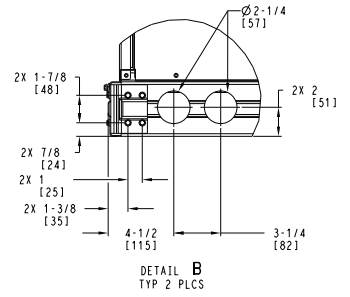

RHV150 Base Unit Dimensions

- NOTES:
1. DIMENSIONS ARE IN INCHES. DIMENSIONS IN [] ARE IN MILLIMETERS.
 2. CENTER OF GRAVITY
 3. DIRECTION OF AIR FLOW



THIS DOCUMENT IS THE PROPERTY OF CARRIER CORPORATION AND IS DELIVERED UPON THE EXPRESS CONDITION THAT THE CONTENTS WILL NOT BE DISCLOSED OR USED WITHOUT WRITTEN CONSENT.

SUBMISSION OF THESE DRAWINGS OR DOCUMENTS DOES NOT CONSTITUTE PART PERFORMANCE OR ACCEPTANCE OF CONTRACT.

CONNECTION SIZES	
B	2 1/2" [64] DIA POWER SUPPLY HOLE
D	7/8" [22] DIA FIELD CONTROL WIRING HOLE
E	3/4"-14 NPT CONDENSATE DRAIN
F	7/8" [22] DIA FIELD CONVENIENCE OUTLET HOLE

THRU-THE-BASE CHART THESE HOLES REQUIRED FOR USE CRBTMPWRO5A00, 006A00, 007A00			
ACCESSORY NO.	THREADED CONDUIT SIZE	WIRE USE	REQ'D HOLE SIZES (MAX.)
005	W 1/2"	ACC.	7/8" [22.2]
	X 1/2"	24V	7/8" [22.2]
	Y 1 1/4"	POWER	1 1/2" [38.1]
006	W 1/2"	ACC.	7/8" [22.2]
	Y 1 1/2"	POWER	2" [50.8]
007	W 1/2"	ACC.	7/8" [22.2]
	X 1/2"	24V	7/8" [22.2]
	Y 2"	POWER	2 1/2" [63.5]

FOR "THRU-THE-BASEPAN" FACTORY OPTION, FITTINGS FOR X & Y ARE PROVIDED AS SPECIFIED ON "006".

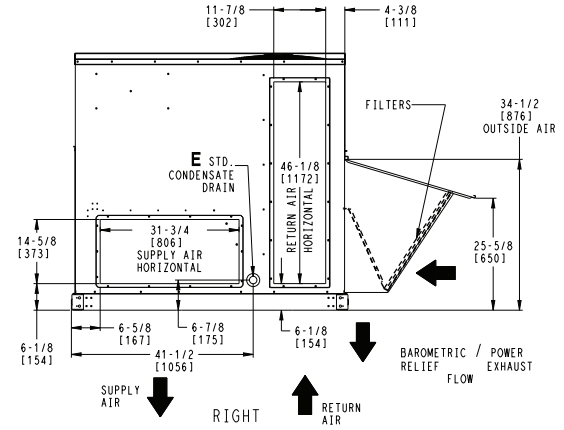
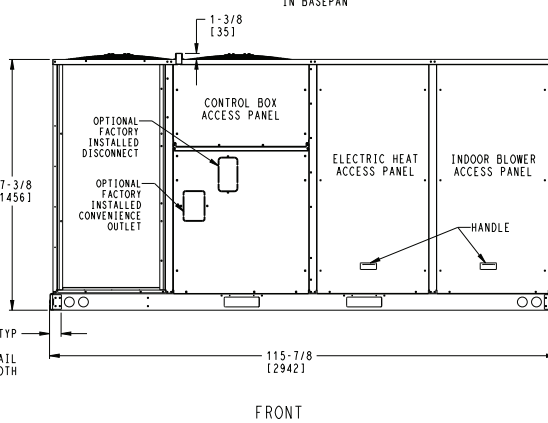
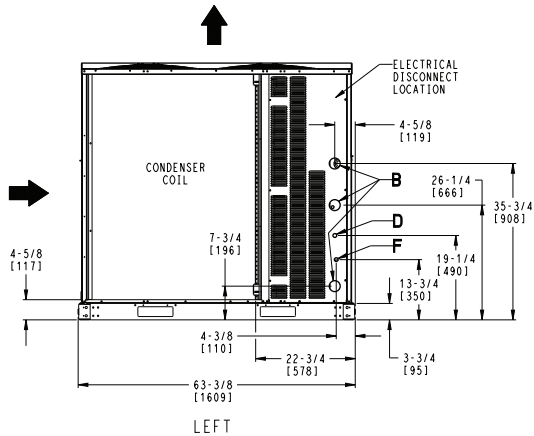
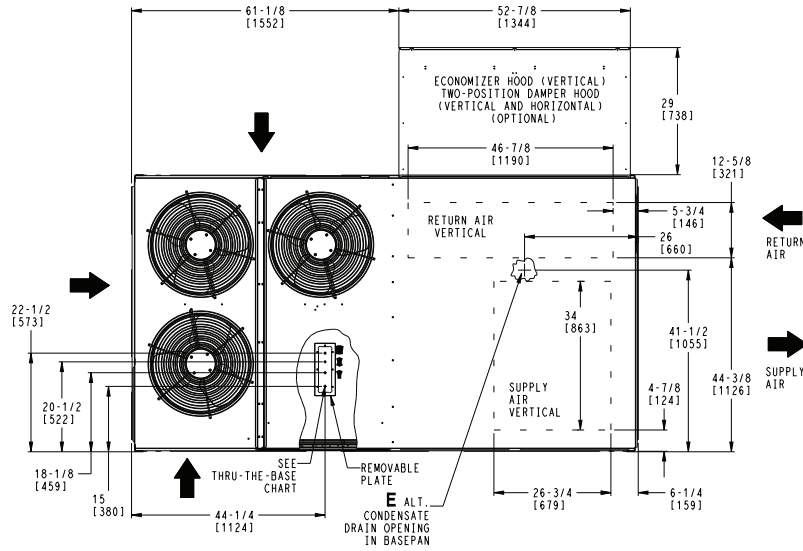
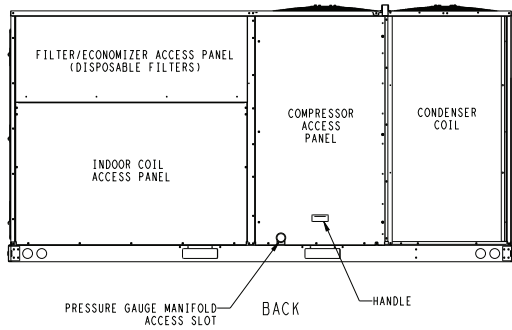

ITC CLASSIFICATION	SHEET	DATE	SUPERCEDES	RHV 150 SINGLE ZONE ELECTRICAL HEAT PUMP	50TM002594	REV
U.S. ECCN:NSR	1 OF 2	5/4/22	-			-

RHV150 Base Unit Dimensions (cont)

UNIT	STD UNIT WEIGHT		CORNER WEIGHT (A)		CORNER WEIGHT (B)		CORNER WEIGHT (C)		CORNER WEIGHT (D)		C.G.		
	LBS.	KG.	LBS.	KG.	LBS.	KG.	LBS.	KG.	LBS.	KG.	X	Y	Z
RHV-150	1250	567	350	159	338	153	277	125	286	130	57 [1448]	28 1/2 [724]	24 [610]

STANDARD UNIT WEIGHT IS WITHOUT ELECTRIC HEAT & WITHOUT PACKAGING. FOR OPTIONS & ACCESSORIES, REFER TO THE PRODUCT DATA CATALOG.

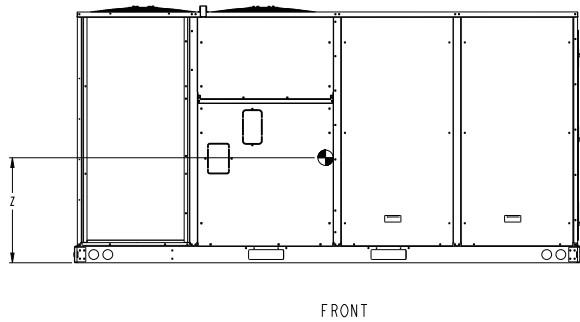
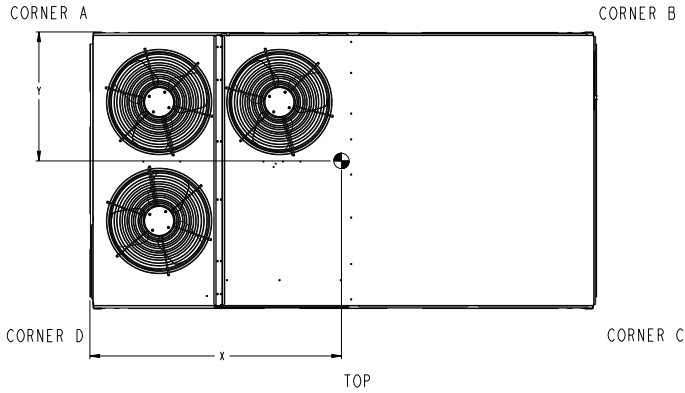

THIS DOCUMENT IS THE PROPERTY OF CARRIER CORPORATION AND IS DELIVERED UPON THE EXPRESS CONDITION THAT THE CONTENTS WILL NOT BE DISCLOSED OR USED WITHOUT WRITTEN CONSENT.

SUBMISSION OF THESE DRAWINGS OR DOCUMENTS DOES NOT CONSTITUTE PART PERFORMANCE OR ACCEPTANCE OF CONTRACT.

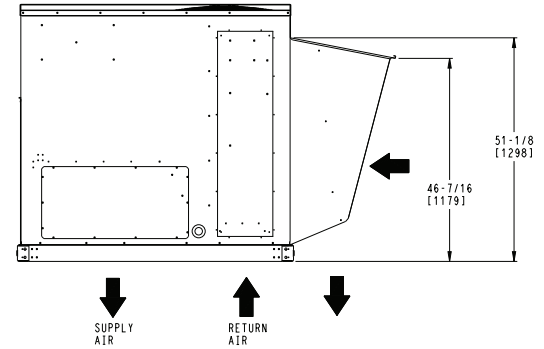
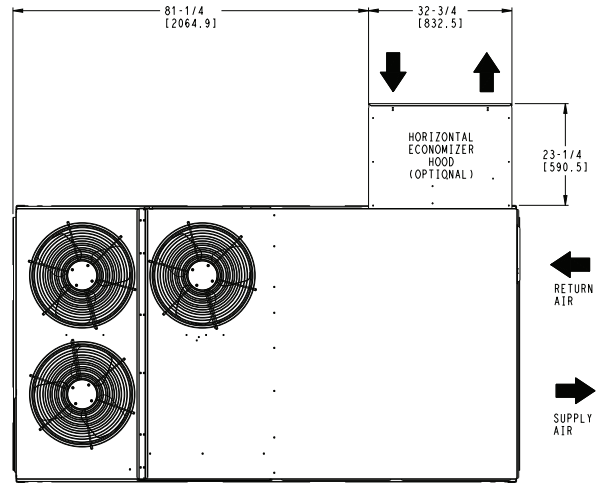

HORIZONTAL ECONOMIZER

ITC CLASSIFICATION U.S. ECCN:NSR	SHEET 2 OF 2	DATE 5/4/22	SUPERCEDES -	RHV 150 SINGLE ZONE ELECTRICAL HEAT PUMP	50TM002594	REV -
-------------------------------------	-----------------	----------------	-----------------	---	------------	----------

Base unit dimensions (cont)

RHV150 Base Unit Dimensions — Clearances

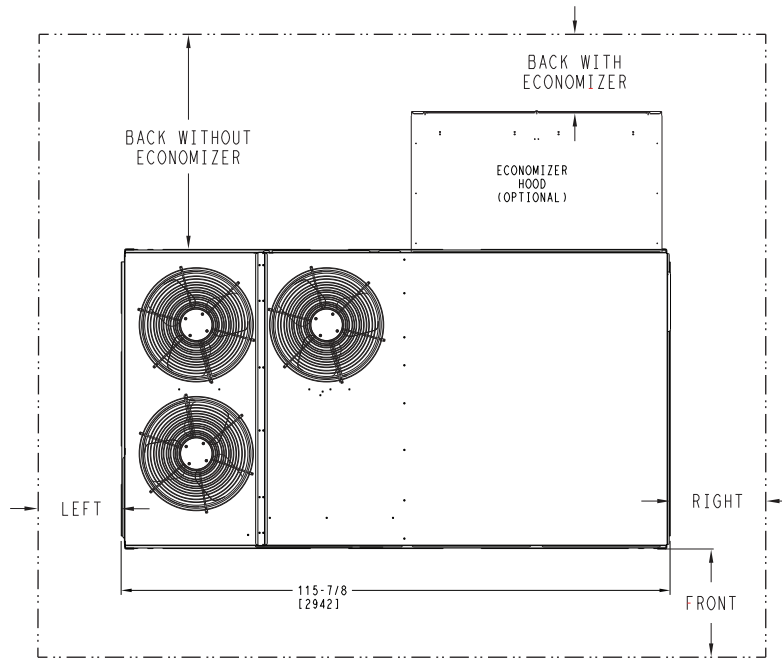

CLEARANCE^{a, b}

SURFACE	Service with Conductive Barrier	Service with Non-conductive Barrier	Operating Clearance
FRONT	48 in. (1219 mm)	36 in. (914 mm)	18 in. (457 mm)
LEFT	48 in. (1219 mm)	42 in. (1067 mm)	18 in. (457 mm)
BACK W/O ECONOMIZER	48 in. (1219 mm)	42 in. (1067 mm)	18 in. (457 mm)
BACK W/ ECONOMIZER	36 in. (914 mm)	36 in. (914 mm)	18 in. (457 mm)
RIGHT	36 in. (914 mm)	36 in. (914 mm)	18 in. (457 mm)
LEFT	72 in. (1829 mm)	72 in. (1829 mm)	72 in. (1829 mm)

NOTE(S):

- a. For all minimum clearances local codes or jurisdictions may prevail.
- b. See page 12 for RHV090-102 clearances. See page 15 for RHV120 clearances.

Roof Curb Dimensions — RHV090-120

ROOF CURB ACCESSORY #	A
CRRFCURB003A01	14" [356]
CRRFCURB004A01	24" [610]

- NOTES:
 1. ROOFCURB ACCESSORY IS SHIPPED DISASSEMBLED.
 2. INSULATED PANELS: 25.4 [1"] THK. POLYURETHANE FOAM, 44.5 [1-3/4] # DENSITY.
 3. DIMENSIONS IN [] ARE IN MILLIMETERS.
 4. ROOFCURB: 18 GAGE STEEL.
 5. ATTACH DUCTWORK TO CURB. (FLANGES OF DUCT REST ON CURB).
 6. SERVICE CLEARANCE 4 FEET ON EACH SIDE.
 7. DIRECTION OF AIR FLOW.
 8. CONNECTOR PACKAGE CRBTMPWR002A01 IS FOR THRU-THE-CURB GAS TYPE PACKAGE CRBTMPWR004A01 IS FOR THRU-THE-BOTTOM TYPE GAS CONNECTIONS.

CONNECTOR PKG. ACC.	GAS CONNECTION TYPE	GAS FITTING	POWER WIRING FITTING	CONTROL WIRING FITTING	ACCESSORY CONVENIENCE OUTLET WIRING CONNECTOR
CRBTMPWR002A01	THRU THE CURB	3/4" [19] NPT	1 1/4" [31.7] NPT	1/2" [12.7] NPT	1/2" [12.7] NPT
CRBTMPWR004A01	THRU THE BOTTOM				

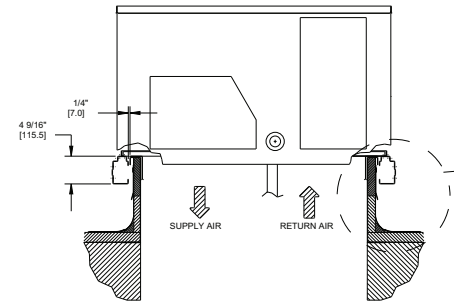
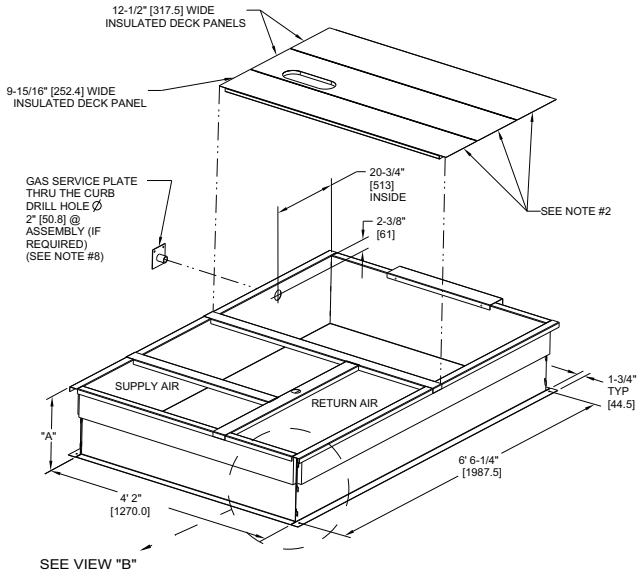
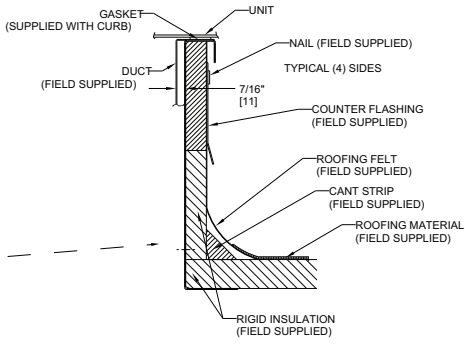
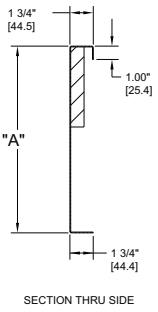
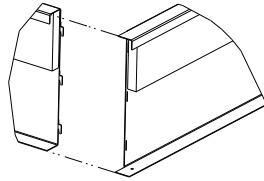
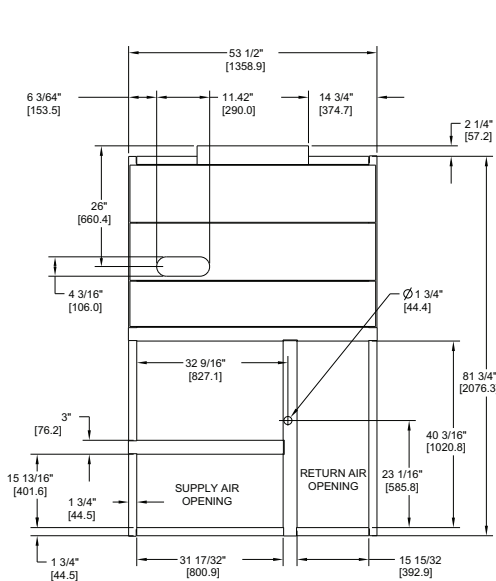

REV	REVISION RECORD	DATE	BY	CHK'D	APP'D	ECN NO.
C	6' 6 1/4" WAS 6' 7 1/8", 4' 2" WAS 4' 2 13/16"; 18 GA WAS 16 GA.; 15 13/16" WAS 15 15/16"; NAIL FIELD SUPPLIED WAS WITH CURB	4/22/13	MMC	-	-	1067898

DRAWING RELEASE LEVEL: PRODUCTION		UNLESS OTHERWISE SPECIFIED DIMENSIONS ARE IN INCHES TOLERANCES ON:		THIS DOCUMENT AND THE INFORMATION CONTAINED THEREIN IS PROPRIETARY TO CARRIER CORPORATION AND SHALL NOT BE USED OR DISCLOSED TO OTHERS, IN WHOLE OR IN PART, WITHOUT THE WRITTEN AUTHORIZATION OF CARRIER CORPORATION.	
THIRD ANGLE PROJECTION		1 DEC	2 DEC	3 DEC	ANG
MATERIAL	-	±	±	±	±
ENGINEERING REQUIREMENTS	T-005, Y-002	AUTHORIZATION NUMBER		TITLE	
WEIGHT	-	1029120		CURB ASY, ROOF	
SURFACE FINISH	MFG/PURCH PURCH	ENGINEERING	MANUFACTURING	SIZE	DRAWING NUMBER
MODEL (INTERNAL USE ONLY)	-	DRAFTER	CHECKER	D	50HJ405012
NEXT DRAWING	SCALE	SHEET 5 OF 5		DISTRI	REV
-	N/A	-		-	C

Roof Curb Dimensions — RHV150

ROOF CURB ACCESSORY #	A
CRRFCURB074A00	14" [356]
CRRFCURB075A00	24" [610]

- NOTES:
1. ROOFCURB ACCESSORY IS SHIPPED DISASSEMBLED.
 2. INSULATED PANELS: 1/2" THK. NEOPRENE FOAM, 1.0# DENSITY.
 3. DIMENSIONS IN [] ARE IN MILLIMETERS.
 4. ROOFCURB SIDEWALLS: 16 GAGE STEEL.
 5. ATTACH DUCTWORK TO CURB. (FLANGES OF DUCT REST ON CURB).
 6. SERVICE CLEARANCE 4 FT ON EACH SIDE.
 7. DIRECTION OF AIR FLOW.
 8. "L" & "S" DESIGNATIONS DENOTE LOCATION OF COMMON CROSS RAIL. (POSITION "L" FOR LARGE DUCT OPENING CURB).

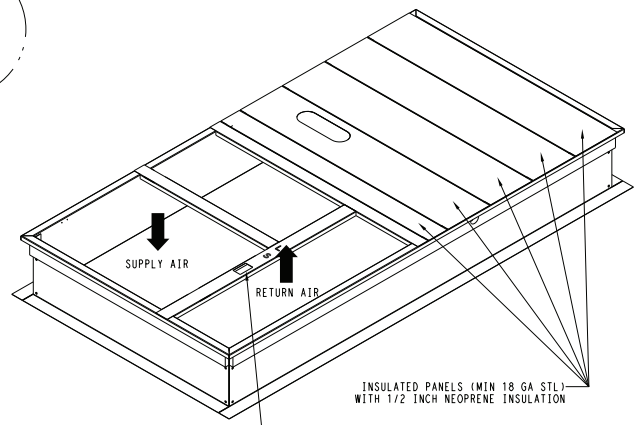
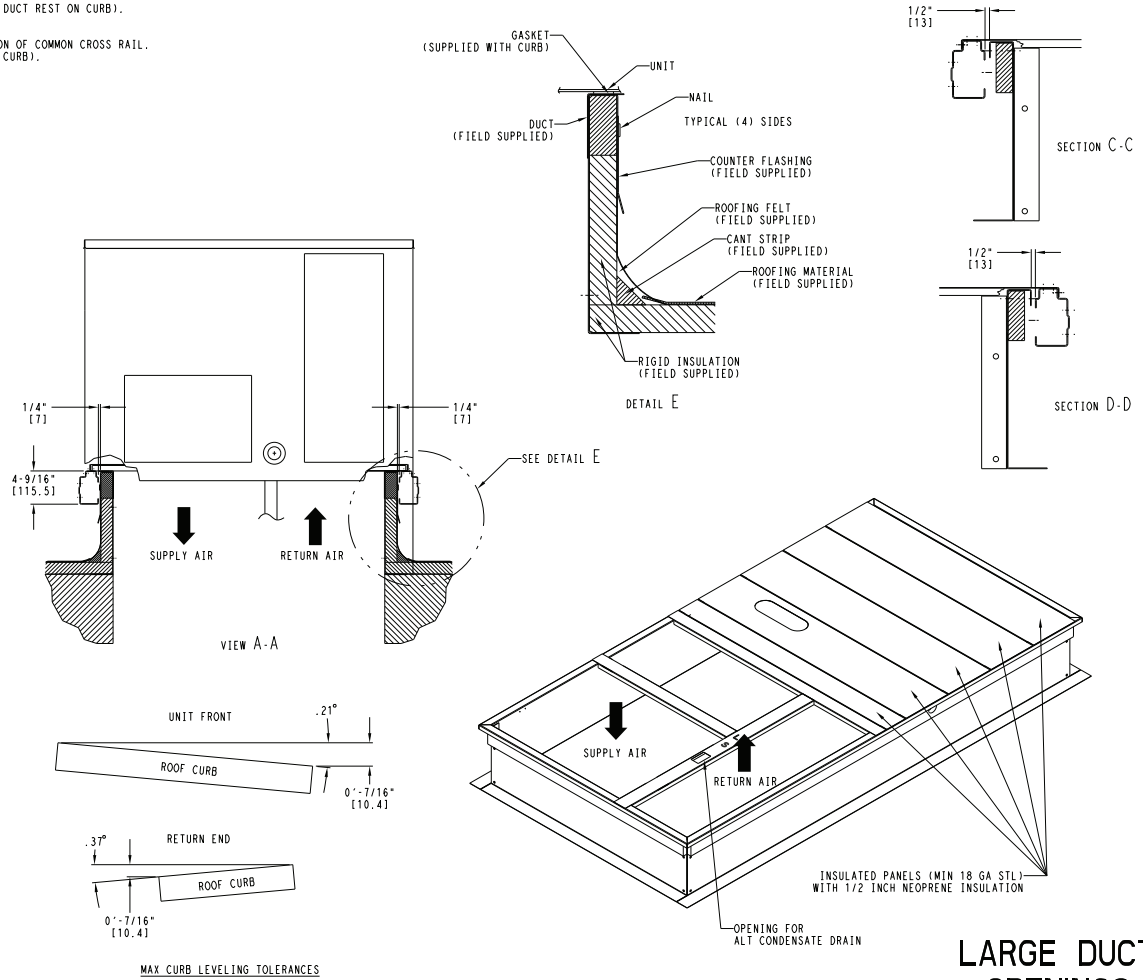
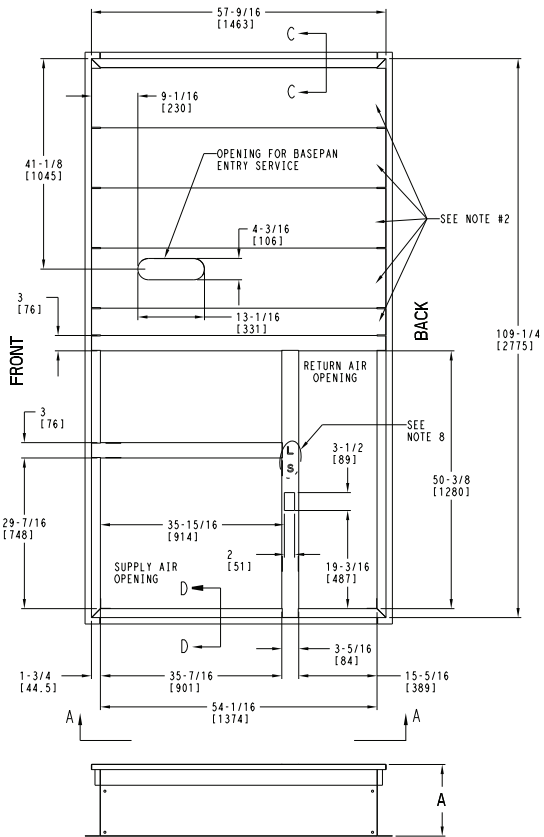

LARGE DUCT OPENINGS

50TM500780	REV B
------------	-------

Performance data

RHV090 Two Stage Cooling Capacities

RHV090			AMBIENT TEMPERATURE (°F)																
			85			95			105			115			125				
			EAT (db)			EAT (db)			EAT (db)			EAT (db)			EAT (db)				
			75	80	85	75	80	85	75	80	85	75	80	85	75	80	85		
2250 cfm	EAT (wb)	58	TC	76.1	76.1	86.7	71.2	71.2	81.4	66.0	66.0	75.8	60.7	60.7	70.0	55.1	55.1	63.9	
			SHC	65.4	76.1	86.7	60.9	71.2	81.4	56.2	66.0	75.8	51.3	60.7	70.0	46.2	55.1	63.9	
		62	TC	80.9	80.9	82.4	75.0	75.0	78.6	68.8	68.8	74.6	62.4	62.4	70.5	55.8	55.8	66.1	
			SHC	58.9	70.6	82.4	55.1	66.8	78.6	51.2	62.9	74.6	47.2	58.8	70.5	43.0	54.5	66.1	
		67	TC	90.6	90.6	90.6	84.3	84.3	84.3	77.6	77.6	77.6	70.8	70.8	70.8	63.6	63.6	63.6	
			SHC	48.2	60.0	71.9	44.5	56.3	68.1	40.6	52.4	64.2	36.6	48.4	60.2	32.6	44.4	56.2	
	72	TC	101.1	101.1	101.1	94.4	94.4	94.4	87.3	87.3	87.3	80.0	80.0	80.0	72.4	72.4	72.4		
		SHC	37.3	49.2	61.1	33.5	45.4	57.4	29.7	41.6	53.5	25.8	37.7	49.5	21.8	33.6	45.5		
	76	TC	—	110.1	110.1	—	103.0	103.0	—	95.6	95.6	—	87.9	87.9	—	79.8	79.8		
		SHC	—	40.4	52.8	—	36.7	49.0	—	32.8	45.1	—	28.9	41.1	—	24.9	37.0		
	2650 cfm	EAT (wb)	58	TC	81.6	81.6	92.8	76.4	76.4	87.2	70.9	70.9	81.3	65.2	65.2	75.1	59.3	59.3	68.6
				SHC	70.3	81.6	92.8	65.5	76.4	87.2	60.6	70.9	81.3	55.4	65.2	75.1	50.0	59.3	68.6
62			TC	84.3	84.3	91.9	78.2	78.2	87.9	71.8	71.8	83.5	66.4	66.4	75.4	59.4	59.4	71.8	
			SHC	64.7	78.3	91.9	60.8	74.3	87.9	56.6	70.1	83.5	50.8	63.1	75.4	46.9	59.4	71.8	
67			TC	94.0	94.0	94.0	87.4	87.4	87.4	80.4	80.4	80.4	73.2	73.2	73.2	65.8	65.8	65.8	
			SHC	52.1	65.9	79.7	48.3	62.0	75.8	44.3	58.1	71.8	40.3	54.1	67.8	36.2	50.0	63.7	
72		TC	104.7	104.7	104.7	97.7	97.7	97.7	90.3	90.3	90.3	82.6	82.6	82.6	74.7	74.7	74.7		
		SHC	39.2	53.0	66.9	35.3	49.2	63.1	31.4	45.2	59.1	27.4	41.2	55.0	23.3	37.1	50.9		
76		TC	—	113.8	113.8	—	106.3	106.3	—	98.6	98.6	—	90.6	90.6	—	82.2	82.2		
		SHC	—	42.6	56.9	—	38.8	53.0	—	34.8	49.0	—	30.8	44.9	—	26.7	40.8		
3000 cfm		EAT (wb)	58	TC	85.6	85.6	97.4	80.2	80.2	91.4	74.5	74.5	85.2	68.5	68.5	78.7	62.3	62.3	72.0
				SHC	73.9	85.6	97.4	68.9	80.2	91.4	63.7	74.5	85.2	58.3	68.5	78.7	52.7	62.3	72.0
	62		TC	86.8	86.8	99.5	80.5	80.5	95.4	74.6	74.6	88.9	68.6	68.6	82.3	62.4	62.4	75.3	
			SHC	69.3	84.4	99.5	65.3	80.3	95.4	60.2	74.6	88.9	55.0	68.6	82.3	49.5	62.4	75.3	
	67		TC	96.3	96.3	96.3	89.5	89.5	89.5	82.3	82.3	82.3	74.9	74.9	74.9	67.2	67.2	69.9	
			SHC	55.3	70.7	86.2	51.4	66.9	82.3	47.4	62.8	78.3	43.4	58.7	74.1	39.2	54.5	69.9	
	72	TC	107.1	107.1	107.1	99.8	99.8	99.8	92.3	92.3	92.3	84.4	84.4	84.4	76.2	76.2	76.2		
		SHC	40.6	56.1	71.7	36.7	52.2	67.7	32.7	48.2	63.7	28.7	44.2	59.6	24.6	40.0	55.4		
	76	TC	—	116.3	116.3	—	108.6	108.6	—	100.6	100.6	—	92.4	92.4	—	—	—		
		SHC	—	44.3	60.2	—	40.4	56.2	—	36.4	52.2	—	32.4	48.1	—	—	—		
	3400 cfm	EAT (wb)	58	TC	89.6	89.6	101.8	83.9	83.9	95.6	77.9	77.9	89.1	71.7	71.7	82.3	65.3	65.3	75.2
				SHC	77.5	89.6	101.8	72.2	83.9	95.6	66.8	77.9	89.1	61.2	71.7	82.3	55.3	65.3	75.2
62			TC	90.8	90.8	102.4	85.0	85.0	96.1	78.0	78.0	92.9	71.8	71.8	86.0	65.3	65.3	78.7	
			SHC	71.8	87.1	102.4	66.8	81.5	96.1	63.2	78.0	92.9	57.7	71.8	86.0	52.0	65.3	78.7	
67			TC	98.4	98.4	98.4	91.4	91.4	91.4	84.0	84.0	85.3	76.4	76.4	81.0	68.6	68.6	76.6	
			SHC	58.7	76.0	93.3	54.8	72.1	89.3	50.8	68.0	85.3	46.6	63.8	81.0	42.4	59.5	76.6	
72		TC	109.3	109.3	109.3	101.8	101.8	101.8	94.0	94.0	94.0	86.0	86.0	86.0	77.6	77.6	77.6		
		SHC	42.0	59.4	76.8	38.1	55.5	72.8	34.1	51.4	68.8	30.0	47.3	64.6	25.8	43.1	60.4		
76		TC	—	118.5	118.5	—	110.7	110.7	—	102.5	102.5	—	—	—	—	—	—		
		SHC	—	46.0	63.7	—	42.0	59.7	—	38.0	55.7	—	—	—	—	—	—		
3750 cfm		EAT (wb)	58	TC	92.6	92.6	105.1	86.7	86.7	98.7	80.6	80.6	92.0	74.1	74.1	85.0	67.4	67.4	77.7
				SHC	80.1	92.6	105.1	74.7	86.7	98.7	69.1	80.6	92.0	63.3	74.1	85.0	57.2	67.4	77.7
	62		TC	92.7	92.7	109.4	86.8	86.8	102.8	80.6	80.6	95.9	74.2	74.2	88.7	67.5	67.5	81.2	
			SHC	76.0	92.7	109.4	70.8	86.8	102.8	65.4	80.6	95.9	59.7	74.2	88.7	53.9	67.5	81.2	
	67		TC	99.9	99.9	99.9	92.7	92.7	95.3	85.3	85.3	91.1	77.6	77.6	86.8	69.6	69.6	82.2	
			SHC	61.6	80.5	99.4	57.6	76.5	95.3	53.5	72.3	91.1	49.4	68.1	86.8	45.0	63.6	82.2	
	72	TC	110.8	110.8	110.8	103.2	103.2	103.2	95.3	95.3	95.3	87.1	87.1	87.1	78.5	78.5	78.5		
		SHC	43.2	62.2	81.1	39.2	58.2	77.1	35.2	54.1	73.1	31.1	50.0	68.9	26.9	45.7	64.6		
	76	TC	—	120.1	120.1	—	112.1	112.1	—	—	—	—	—	—	—	—	—		
		SHC	—	47.4	66.7	—	43.4	62.6	—	—	—	—	—	—	—	—	—		

LEGEND

- Do Not Operate
- cfm — Cubic Feet Per Minute (Supply Air)
- EAT (db) — Entering Air Temperature (dry bulb)
- EAT (wb) — Entering Air Temperature (wet bulb)
- SHC — Sensible Heat Capacity (1000 Btuh) Gross
- TC — Total Capacity (1000 Btuh) Gross

NOTE: See minimum-maximum airflow ratings on page 5.

Performance data (cont)

RHV090 Single Stage Cooling Capacities

RHV090			AMBIENT TEMPERATURE (°F)																
			85			95			105			115			125				
			EAT (db)			EAT (db)			EAT (db)			EAT (db)			EAT (db)				
			75	80	85	75	80	85	75	80	85	75	80	85	75	80	85		
1125 cfm	EAT (wb)	58	TC	36.3	36.3	41.9	33.0	33.0	38.4	29.6	29.6	34.8	26.0	26.0	31.0	22.4	22.4	27.0	
			SHC	30.7	36.3	41.9	27.6	33.0	38.4	24.4	29.6	34.8	21.1	26.0	31.0	17.7	22.4	27.0	
		62	TC	39.4	39.4	39.6	35.5	35.5	36.7	31.5	31.5	33.9	27.2	27.2	31.0	22.9	22.9	28.0	
			SHC	27.4	33.5	39.6	24.6	30.7	36.7	21.8	27.8	33.9	18.9	24.9	31.0	15.9	22.0	28.0	
		67	TC	45.2	45.2	45.2	41.1	41.1	41.1	36.8	36.8	36.8	32.4	32.4	32.4	27.7	27.7	27.7	
			SHC	22.5	28.6	34.7	19.7	25.8	31.9	16.9	23.0	29.0	14.0	20.1	26.1	11.1	17.1	23.2	
	72	TC	51.5	51.5	51.5	47.2	47.2	47.2	42.6	42.6	42.6	37.9	37.9	37.9	33.0	33.0	33.0		
		SHC	17.5	23.6	29.7	14.7	20.8	26.9	11.9	18.0	24.1	9.0	15.1	21.2	6.1	12.2	18.3		
	76	TC	—	56.9	56.9	—	52.4	52.4	—	47.6	47.6	—	42.7	42.7	—	—	—		
		SHC	—	19.5	25.7	—	16.8	22.9	—	13.9	20.1	—	11.0	17.2	—	—	—		
	1325 cfm	EAT (wb)	58	TC	39.7	39.7	45.6	36.2	36.2	41.9	32.6	32.6	38.0	28.8	28.8	34.0	24.9	24.9	29.8
				SHC	33.7	39.7	45.6	30.4	36.2	41.9	27.1	32.6	38.0	23.6	28.8	34.0	20.0	24.9	29.8
62			TC	41.5	41.5	44.9	37.4	37.4	42.0	33.2	33.2	39.0	28.9	28.9	35.9	25.0	25.0	31.6	
			SHC	30.7	37.8	44.9	27.9	35.0	42.0	24.9	32.0	39.0	21.9	28.9	35.9	18.4	25.0	31.6	
67			TC	47.3	47.3	47.3	43.0	43.0	43.0	38.6	38.6	38.6	33.9	33.9	33.9	29.0	29.0	29.0	
			SHC	24.8	31.9	39.0	22.0	29.1	36.2	19.1	26.2	33.3	16.1	23.2	30.3	13.1	20.2	27.3	
72		TC	53.7	53.7	53.7	49.2	49.2	49.2	44.5	44.5	44.5	39.5	39.5	39.5	34.5	34.5	34.5		
		SHC	18.8	25.9	33.1	15.9	23.1	30.2	13.0	20.2	27.3	10.0	17.2	24.4	7.0	14.2	21.3		
76		TC	—	59.2	59.2	—	54.5	54.5	—	—	—	—	—	—	—	—	—		
		SHC	—	21.0	28.3	—	18.2	25.5	—	—	—	—	—	—	—	—	—		
1500 cfm		EAT (wb)	58	TC	42.2	42.2	48.4	38.5	38.5	44.5	34.7	34.7	40.5	30.8	30.8	36.3	26.8	26.8	31.9
				SHC	35.9	42.2	48.4	32.6	38.5	44.5	29.0	34.7	40.5	25.4	30.8	36.3	21.6	26.8	31.9
	62		TC	43.0	43.0	49.3	38.8	38.8	46.2	34.8	34.8	42.5	30.9	30.9	38.2	26.8	26.8	33.7	
			SHC	33.4	41.4	49.3	30.5	38.3	46.2	27.2	34.8	42.5	23.6	30.9	38.2	20.0	26.8	33.7	
	67		TC	48.9	48.9	48.9	44.4	44.4	44.4	39.7	39.7	39.7	34.9	34.9	34.9	29.9	29.9	30.7	
			SHC	26.7	34.7	42.7	23.8	31.8	39.8	20.8	28.8	36.8	17.8	25.8	33.8	14.7	22.7	30.7	
	72	TC	55.3	55.3	55.3	50.6	50.6	50.6	45.7	45.7	45.7	40.6	40.6	40.6	35.4	35.4	35.4		
		SHC	19.7	27.8	35.8	16.8	24.9	32.9	13.9	21.9	30.0	10.9	18.9	27.0	7.8	15.8	23.9		
	76	TC	—	60.8	60.8	—	—	—	—	—	—	—	—	—	—	—	—		
		SHC	—	22.2	30.4	—	—	—	—	—	—	—	—	—	—	—	—		
	1700 cfm	EAT (wb)	58	TC	44.7	44.7	51.1	40.8	40.8	47.0	36.9	36.9	42.9	32.8	32.8	38.4	28.6	28.6	33.9
				SHC	38.2	44.7	51.1	34.6	40.8	47.0	31.0	36.9	42.9	27.2	32.8	38.4	23.3	28.6	33.9
62			TC	44.7	44.7	53.4	40.9	40.9	49.2	37.0	37.0	44.9	32.9	32.9	40.4	28.6	28.6	35.7	
			SHC	36.0	44.7	53.4	32.6	40.9	49.2	29.0	37.0	44.9	25.3	32.9	40.4	21.5	28.6	35.7	
67			TC	50.1	50.1	50.1	45.5	45.5	45.5	40.8	40.8	40.8	35.9	35.9	37.7	30.8	30.8	34.5	
			SHC	28.7	37.7	46.7	25.7	34.8	43.8	22.7	31.7	40.8	19.7	28.7	37.7	16.6	25.5	34.5	
72		TC	56.7	56.7	56.7	51.9	51.9	51.9	46.8	46.8	46.8	41.6	41.6	41.6	36.2	36.2	36.2		
		SHC	20.7	29.8	38.9	17.8	26.8	35.9	14.8	23.8	32.9	11.7	20.8	29.8	8.6	17.7	26.7		
76		TC	—	—	—	—	—	—	—	—	—	—	—	—	—	—	—		
		SHC	—	—	—	—	—	—	—	—	—	—	—	—	—	—	—		
1875 cfm		EAT (wb)	58	TC	46.5	46.5	53.2	42.6	42.6	49.0	38.5	38.5	44.6	34.3	34.3	40.1	29.9	29.9	35.4
				SHC	39.8	46.5	53.2	36.2	42.6	49.0	32.4	38.5	44.6	28.5	34.3	40.1	24.5	29.9	35.4
	62		TC	46.6	46.6	55.5	42.6	42.6	51.2	38.6	38.6	46.8	34.4	34.4	42.1	30.0	30.0	37.3	
			SHC	37.7	46.6	55.5	34.1	42.6	51.2	30.4	38.6	46.8	26.6	34.4	42.1	22.7	30.0	37.3	
	67		TC	51.1	51.1	51.1	46.4	46.4	47.1	41.5	41.5	44.1	36.5	36.5	40.9	31.4	31.4	37.7	
			SHC	30.4	40.3	50.2	27.4	37.3	47.1	24.3	34.2	44.1	21.2	31.0	40.9	18.0	27.9	37.7	
	72	TC	57.7	57.7	57.7	52.7	52.7	52.7	47.6	47.6	47.6	42.3	42.3	42.3	—	—	—		
		SHC	21.5	31.5	41.4	18.5	28.5	38.4	15.5	25.5	35.4	12.4	22.4	32.3	—	—	—		
	76	TC	—	—	—	—	—	—	—	—	—	—	—	—	—	—	—		
		SHC	—	—	—	—	—	—	—	—	—	—	—	—	—	—	—		

LEGEND

- Do Not Operate
- cfm — Cubic Feet Per Minute (Supply Air)
- EAT (db) — Entering Air Temperature (dry bulb)
- EAT (wb) — Entering Air Temperature (wet bulb)
- SHC — Sensible Heat Capacity (1000 Btuh) Gross
- TC — Total Capacity (1000 Btuh) Gross

NOTE: See minimum-maximum airflow ratings on page 5.

Performance data (cont)

RHV102 Two Stage Cooling Capacities

RHV102			AMBIENT TEMPERATURE (°F)																
			85			95			105			115			125				
			EAT (db)			EAT (db)			EAT (db)			EAT (db)			EAT (db)				
			75	80	85	75	80	85	75	80	85	75	80	85	75	80	85		
2550 cfm	EAT (wb)	58	TC	86.2	86.2	97.9	81.2	81.2	92.5	76.0	76.0	86.8	70.5	70.5	80.9	64.8	64.8	74.6	
		SHC	74.4	86.2	97.9	69.8	81.2	92.5	65.1	76.0	86.8	60.1	70.5	80.9	55.0	64.8	74.6		
		62	TC	91.1	91.1	93.5	85.0	85.0	89.7	78.7	78.7	85.8	72.2	72.2	81.6	65.5	65.5	77.1	
		SHC	67.2	80.4	93.5	63.5	76.6	89.7	59.6	72.7	85.8	55.6	68.6	81.6	51.4	64.3	77.1		
		67	TC	101.5	101.5	101.5	95.0	95.0	95.0	88.3	88.3	88.3	81.2	81.2	81.2	73.9	73.9	73.9	
		SHC	55.1	68.3	81.5	51.3	64.6	77.8	47.5	60.8	74.0	43.7	56.9	70.1	39.7	52.9	66.1		
	72	TC	112.8	112.8	112.8	106.0	106.0	106.0	98.8	98.8	98.8	91.3	91.3	91.3	83.5	83.5	83.5		
	SHC	42.5	55.9	69.3	38.9	52.2	65.5	35.1	48.4	61.7	31.2	44.5	57.8	27.3	40.6	53.8			
	76	TC	—	122.4	122.4	—	115.2	115.2	—	107.6	107.6	—	99.8	99.8	—	91.5	91.5		
	SHC	—	45.8	59.9	—	42.2	56.1	—	38.4	52.3	—	34.6	48.3	—	30.6	44.3			
	3000 cfm	EAT (wb)	58	TC	91.9	91.9	104.4	86.7	86.7	98.6	81.1	81.1	92.6	75.3	75.3	86.2	69.3	69.3	79.6
			SHC	79.5	91.9	104.4	74.7	86.7	98.6	69.7	81.1	92.6	64.4	75.3	86.2	58.9	69.3	79.6	
62			TC	94.6	94.6	103.8	88.4	88.4	99.7	82.0	82.0	95.3	75.5	75.5	90.0	69.4	69.4	83.2	
SHC			73.5	88.6	103.8	69.6	84.6	99.7	65.4	80.4	95.3	60.9	75.5	90.0	55.6	69.4	83.2		
67			TC	105.1	105.1	105.1	98.3	98.3	98.3	91.3	91.3	91.3	83.9	83.9	83.9	76.2	76.2	76.2	
SHC			59.2	74.6	90.0	55.5	70.8	86.2	51.6	66.9	82.3	47.7	63.0	78.3	43.6	58.9	74.2		
72		TC	116.6	116.6	116.6	109.4	109.4	109.4	101.9	101.9	101.9	94.1	94.1	94.1	86.0	86.0	86.0		
SHC		44.5	59.9	75.4	40.7	56.2	71.6	36.9	52.3	67.8	33.0	48.4	63.8	29.0	44.3	59.7			
76		TC	—	126.3	126.3	—	118.7	118.7	—	110.9	110.9	—	102.6	102.6	—	94.0	94.0		
SHC		—	48.1	64.1	—	44.3	60.3	—	40.5	56.4	—	36.6	52.4	—	32.5	48.3			
3400 cfm		EAT (wb)	58	TC	96.3	96.3	109.2	90.8	90.8	103.2	85.0	85.0	96.9	78.9	78.9	90.2	72.6	72.6	83.3
			SHC	83.4	96.3	109.2	78.4	90.8	103.2	73.1	85.0	96.9	67.6	78.9	90.2	61.9	72.6	83.3	
	62		TC	97.4	97.4	111.9	92.2	92.2	103.5	85.1	85.1	101.0	79.0	79.0	94.1	72.7	72.7	87.0	
	SHC		78.4	95.2	111.9	72.5	88.0	103.5	69.2	85.1	101.0	63.9	79.0	94.1	58.4	72.7	87.0		
	67		TC	107.5	107.5	107.5	100.6	100.6	100.6	93.3	93.3	93.3	85.7	85.7	85.7	77.9	77.9	81.1	
	SHC		62.7	79.9	97.1	58.9	76.1	93.3	55.0	72.1	89.3	51.0	68.1	85.2	46.9	64.0	81.1		
	72	TC	119.1	119.1	119.1	111.8	111.8	111.8	104.0	104.0	104.0	96.0	96.0	96.0	87.6	87.6	87.6		
	SHC	45.9	63.3	80.6	42.2	59.4	76.7	38.3	55.5	72.8	34.3	51.5	68.7	30.3	47.4	64.6			
	76	TC	—	128.9	128.9	—	121.1	121.1	—	113.0	113.0	—	104.6	104.6	—	95.7	95.7		
	SHC	—	49.8	67.6	—	46.0	63.8	—	42.1	59.8	—	38.2	55.7	—	34.1	51.5			
	3850 cfm	EAT (wb)	58	TC	100.5	100.5	113.9	94.7	94.7	107.6	88.7	88.7	101.0	82.3	82.3	94.0	75.7	75.7	86.8
			SHC	87.1	100.5	113.9	81.8	94.7	107.6	76.4	88.7	101.0	70.6	82.3	94.0	64.7	75.7	86.8	
62			TC	100.6	100.6	118.5	94.8	94.8	112.0	88.8	88.8	105.2	82.4	82.4	98.1	75.8	75.8	90.6	
SHC			82.7	100.6	118.5	77.7	94.8	112.0	72.3	88.8	105.2	66.8	82.4	98.1	61.0	75.8	90.6		
67			TC	109.7	109.7	109.7	102.6	102.6	102.6	95.1	95.1	96.9	87.4	87.4	92.7	79.4	79.4	88.3	
SHC			66.4	85.6	104.8	62.5	81.7	100.9	58.6	77.7	96.9	54.5	73.6	92.7	50.4	69.3	88.3		
72		TC	121.4	121.4	121.4	113.8	113.8	113.8	105.9	105.9	105.9	97.7	97.7	97.7	89.1	89.1	89.1		
SHC		47.4	66.8	86.1	43.6	62.9	82.2	39.7	58.9	78.2	35.7	54.9	74.1	31.6	50.8	69.9			
76		TC	—	131.2	131.2	—	123.2	123.2	—	114.9	114.9	—	106.3	106.3	—	—	—		
SHC		—	51.6	71.3	—	47.7	67.4	—	43.8	63.4	—	39.7	59.2	—	—	—			
4250 cfm		EAT (wb)	58	TC	103.7	103.7	117.4	97.7	97.7	110.9	91.4	91.4	104.0	84.9	84.9	96.9	78.1	78.1	89.5
			SHC	89.9	103.7	117.4	84.5	97.7	110.9	78.8	91.4	104.0	72.9	84.9	96.9	66.8	78.1	89.5	
	62		TC	103.8	103.8	122.1	97.8	97.8	115.4	91.5	91.5	108.4	85.0	85.0	101.0	78.2	78.2	93.3	
	SHC		85.4	103.8	122.1	80.2	97.8	115.4	74.7	91.5	108.4	69.0	85.0	101.0	63.1	78.2	93.3		
	67		TC	111.3	111.3	111.4	104.0	104.0	107.4	96.4	96.4	103.3	88.6	88.6	99.0	80.5	80.5	94.4	
	SHC		69.5	90.5	111.4	65.6	86.5	107.4	61.6	82.4	103.3	57.5	78.2	99.0	53.3	73.8	94.4		
	72	TC	123.1	123.1	123.1	115.4	115.4	115.4	107.3	107.3	107.3	98.9	98.9	98.9	90.2	90.2	90.2		
	SHC	48.6	69.7	90.8	44.8	65.8	86.8	40.8	61.8	82.8	36.8	57.7	78.7	32.7	53.6	74.5			
	76	TC	—	132.9	132.9	—	124.8	124.8	—	116.3	116.3	—	—	—	—	—	—		
	SHC	—	52.9	74.4	—	49.1	70.4	—	45.1	66.4	—	—	—	—	—	—			

LEGEND

- Do Not Operate
- cfm — Cubic Feet Per Minute (Supply Air)
- EAT (db) — Entering Air Temperature (dry bulb)
- EAT (wb) — Entering Air Temperature (wet bulb)
- SHC — Sensible Heat Capacity (1000 Btuh) Gross
- TC — Total Capacity (1000 Btuh) Gross

NOTE: See minimum-maximum airflow ratings on page 5.

Performance data (cont)

RHV102 Single Stage Cooling Capacities

RHV102			AMBIENT TEMPERATURE (°F)																
			85			95			105			115			125				
			EAT (db)			EAT (db)			EAT (db)			EAT (db)			EAT (db)				
			75	80	85	75	80	85	75	80	85	75	80	85	75	80	85		
1300 cfm	EAT (wb)	58	TC	45.2	45.2	51.5	42.4	42.4	48.5	39.5	39.5	45.4	36.4	36.4	42.0	33.2	33.2	38.5	
			SHC	38.9	45.2	51.5	36.3	42.4	48.5	33.6	39.5	45.4	30.8	36.4	42.0	27.9	33.2	38.5	
		62	TC	48.0	48.0	49.1	44.7	44.7	46.9	41.1	41.1	44.7	37.4	37.4	42.3	33.5	33.5	39.8	
			SHC	35.1	42.1	49.1	32.9	39.9	46.9	30.7	37.7	44.7	28.4	35.3	42.3	25.9	32.9	39.8	
		67	TC	54.0	54.0	54.0	50.5	50.5	50.5	46.7	46.7	46.7	42.7	42.7	42.7	38.5	38.5	38.5	
			SHC	29.0	36.0	43.0	26.8	33.8	40.8	24.6	31.6	38.6	22.3	29.3	36.3	19.9	26.9	33.9	
	72	TC	60.6	60.6	60.6	56.9	56.9	56.9	52.9	52.9	52.9	48.6	48.6	48.6	44.1	44.1	44.1		
		SHC	22.7	29.8	36.8	20.6	27.6	34.7	18.3	25.4	32.5	16.1	23.1	30.2	13.7	20.8	27.8		
	76	TC	—	66.3	66.3	—	62.4	62.4	—	58.2	58.2	—	53.7	53.7	—	—	—		
		SHC	—	24.6	31.8	—	22.5	29.7	—	20.3	27.5	—	18.1	25.2	—	—	—		
	1500 cfm	EAT (wb)	58	TC	48.2	48.2	54.9	45.3	45.3	51.7	42.2	42.2	48.4	39.0	39.0	44.9	35.5	35.5	41.1
				SHC	41.6	48.2	54.9	38.9	45.3	51.7	36.1	42.2	48.4	33.1	39.0	44.9	30.0	35.5	41.1
62			TC	49.9	49.9	54.3	46.4	46.4	52.0	42.8	42.8	49.6	39.3	39.3	46.4	35.6	35.6	43.0	
			SHC	38.2	46.3	54.3	36.0	44.0	52.0	33.7	41.7	49.6	31.0	38.7	46.4	28.2	35.6	43.0	
67			TC	56.0	56.0	56.0	52.3	52.3	52.3	48.3	48.3	48.3	44.2	44.2	44.2	39.8	39.8	39.8	
			SHC	31.1	39.2	47.2	28.9	37.0	45.0	26.6	34.7	42.8	24.3	32.4	40.4	21.9	29.9	38.0	
72		TC	62.7	62.7	62.7	58.8	58.8	58.8	54.6	54.6	54.6	50.2	50.2	50.2	45.5	45.5	45.5		
		SHC	23.8	31.9	40.0	21.6	29.7	37.8	19.4	27.5	35.6	17.0	25.1	33.2	14.6	22.7	30.8		
76		TC	—	68.5	68.5	—	64.3	64.3	—	—	—	—	—	—	—	—	—		
		SHC	—	26.0	34.2	—	23.8	32.1	—	—	—	—	—	—	—	—	—		
1700 cfm		EAT (wb)	58	TC	50.8	50.8	57.8	47.8	47.8	54.5	44.6	44.6	51.0	41.2	41.2	47.3	37.5	37.5	43.3
				SHC	43.9	50.8	57.8	41.1	47.8	54.5	38.1	44.6	51.0	35.0	41.2	47.3	31.7	37.5	43.3
	62		TC	51.5	51.5	59.1	48.3	48.3	55.8	44.6	44.6	53.2	41.2	41.2	49.4	37.6	37.6	45.4	
			SHC	41.2	50.2	59.1	38.5	47.2	55.8	36.1	44.6	53.2	33.0	41.2	49.4	29.9	37.6	45.4	
	67		TC	57.5	57.5	57.5	53.7	53.7	53.7	49.6	49.6	49.6	45.3	45.3	45.3	40.8	40.8	41.9	
			SHC	33.1	42.2	51.3	30.9	40.0	49.1	28.6	37.7	46.8	26.2	35.3	44.4	23.8	32.8	41.9	
	72	TC	64.3	64.3	64.3	60.2	60.2	60.2	56.0	56.0	56.0	51.4	51.4	51.4	46.6	46.6	46.6		
		SHC	24.8	33.9	43.1	22.6	31.7	40.9	20.3	29.4	38.5	17.9	27.1	36.2	15.5	24.6	33.7		
	76	TC	—	70.2	70.2	—	—	—	—	—	—	—	—	—	—	—	—		
		SHC	—	27.2	36.4	—	—	—	—	—	—	—	—	—	—	—	—		
	1950 cfm	EAT (wb)	58	TC	53.7	53.7	60.9	50.4	50.4	57.4	47.0	47.0	53.7	43.5	43.5	49.8	39.7	39.7	45.7
				SHC	46.4	53.7	60.9	43.4	50.4	57.4	40.3	47.0	53.7	37.1	43.5	49.8	33.6	39.7	45.7
62			TC	53.7	53.7	63.4	50.5	50.5	59.8	47.1	47.1	56.1	43.5	43.5	52.1	39.7	39.7	47.8	
			SHC	44.0	53.7	63.4	41.2	50.5	59.8	38.2	47.1	56.1	35.0	43.5	52.1	31.7	39.7	47.8	
67			TC	59.0	59.0	59.0	55.0	55.0	55.0	50.9	50.9	51.6	46.4	46.4	49.2	41.8	41.8	46.6	
			SHC	35.5	45.9	56.2	33.2	43.6	54.0	30.9	41.3	51.6	28.5	38.8	49.2	26.0	36.3	46.6	
72		TC	65.9	65.9	65.9	61.7	61.7	61.7	57.3	57.3	57.3	52.6	52.6	52.6	47.6	47.6	47.6		
		SHC	25.9	36.3	46.7	23.6	34.0	44.5	21.3	31.7	42.1	18.9	29.3	39.7	16.5	26.9	37.2		
76		TC	—	—	—	—	—	—	—	—	—	—	—	—	—	—	—		
		SHC	—	—	—	—	—	—	—	—	—	—	—	—	—	—	—		
2150 cfm		EAT (wb)	58	TC	55.6	55.6	63.0	52.2	52.2	59.4	48.7	48.7	55.6	45.1	45.1	51.6	41.1	41.1	47.3
				SHC	48.1	55.6	63.0	45.0	52.2	59.4	41.9	48.7	55.6	38.5	45.1	51.6	34.9	41.1	47.3
	62		TC	55.6	55.6	65.6	52.3	52.3	61.9	48.8	48.8	58.0	45.1	45.1	53.9	41.2	41.2	49.5	
			SHC	45.6	55.6	65.6	42.7	52.3	61.9	39.6	48.8	58.0	36.3	45.1	53.9	32.9	41.2	49.5	
	67		TC	60.0	60.0	60.0	55.9	55.9	57.7	51.7	51.7	55.3	47.2	47.2	52.8	42.5	42.5	50.2	
			SHC	37.3	48.7	60.0	35.0	46.4	57.7	32.7	44.0	55.3	30.2	41.5	52.8	27.7	38.9	50.2	
	72	TC	66.9	66.9	66.9	62.6	62.6	62.6	58.1	58.1	58.1	53.3	53.3	53.3	—	—	—		
		SHC	26.7	38.1	49.5	24.4	35.9	47.3	22.1	33.5	44.9	19.7	31.1	42.5	—	—	—		
	76	TC	—	—	—	—	—	—	—	—	—	—	—	—	—	—	—		
		SHC	—	—	—	—	—	—	—	—	—	—	—	—	—	—	—		

LEGEND

- Do Not Operate
- cfm — Cubic Feet Per Minute (Supply Air)
- EAT (db) — Entering Air Temperature (dry bulb)
- EAT (wb) — Entering Air Temperature (wet bulb)
- SHC — Sensible Heat Capacity (1000 Btuh) Gross
- TC — Total Capacity (1000 Btuh) Gross

NOTE: See minimum-maximum airflow ratings on page 5.

Performance data (cont)

RHV120 Two Stage Cooling Capacities

RHV120			AMBIENT TEMPERATURE (°F)																
			85			95			105			115			125				
			EAT (db)			EAT (db)			EAT (db)			EAT (db)			EAT (db)				
			75	80	85	75	80	85	75	80	85	75	80	85	75	80	85		
3000 cfm	EAT (wb)	58	TC	106.9	106.9	121.5	100.8	100.8	114.9	94.4	94.4	107.9	87.7	87.7	100.7	80.8	80.8	93.1	
			SHC	92.2	106.9	121.5	86.7	100.8	114.9	80.9	94.4	107.9	74.8	87.7	100.7	68.6	80.8	93.1	
		62	TC	113.6	113.6	114.6	106.1	106.1	110.0	98.4	98.4	105.3	90.3	90.3	100.4	82.0	82.0	95.2	
			SHC	82.7	98.7	114.6	78.1	94.1	110.0	73.4	89.4	105.3	68.6	84.5	100.4	63.7	79.5	95.2	
		67	TC	126.4	126.4	126.4	118.3	118.3	118.3	110.0	110.0	110.0	101.3	101.3	101.3	92.4	92.4	92.4	
			SHC	67.7	83.7	99.8	63.1	79.1	95.2	58.5	74.5	90.5	53.7	69.7	85.7	48.9	64.9	80.9	
	72	TC	140.2	140.2	140.2	131.6	131.6	131.6	122.7	122.7	122.7	113.4	113.4	113.4	103.9	103.9	103.9		
		SHC	52.3	68.5	84.7	47.8	63.9	80.1	43.1	59.3	75.4	38.4	54.5	70.6	33.6	49.7	65.8		
	76	TC	—	152.0	152.0	—	142.9	142.9	—	133.4	133.4	—	123.6	123.6	—	113.5	113.5		
		SHC	—	56.0	72.5	—	51.5	68.0	—	46.8	63.3	—	42.1	58.6	—	37.3	53.8		
	3500 cfm	EAT (wb)	58	TC	113.9	113.9	129.4	107.4	107.4	122.3	100.6	100.6	114.9	93.6	93.6	107.1	86.2	86.2	99.0
				SHC	98.5	113.9	129.4	92.6	107.4	122.3	86.4	100.6	114.9	80.0	93.6	107.1	73.3	86.2	99.0
62			TC	117.9	117.9	127.0	110.1	110.1	122.1	102.1	102.1	117.0	94.0	94.0	111.4	86.3	86.3	103.5	
			SHC	90.2	108.6	127.0	85.4	103.8	122.1	80.6	98.8	117.0	75.4	93.4	111.4	69.1	86.3	103.5	
67			TC	130.7	130.7	130.7	122.3	122.3	122.3	113.5	113.5	113.5	104.5	104.5	104.5	95.2	95.2	95.2	
			SHC	72.6	91.1	109.7	67.9	86.5	105.0	63.2	81.7	100.2	58.3	76.9	95.4	53.5	72.0	90.5	
72		TC	144.8	144.8	144.8	135.7	135.7	135.7	126.4	126.4	126.4	116.7	116.7	116.7	106.8	106.8	106.8		
		SHC	54.5	73.2	91.9	49.8	68.5	87.2	45.1	63.7	82.4	40.3	58.9	77.5	35.4	54.0	72.6		
76		TC	—	156.6	156.6	—	147.0	147.0	—	137.1	137.1	—	126.9	126.9	—	116.4	116.4		
		SHC	—	58.6	77.8	—	53.9	73.1	—	49.2	68.2	—	44.4	63.3	—	39.5	58.4		
4000 cfm		EAT (wb)	58	TC	119.8	119.8	136.0	113.0	113.0	128.5	105.8	105.8	120.6	98.4	98.4	112.5	90.6	90.6	104.0
				SHC	103.7	119.8	136.0	97.5	113.0	128.5	91.0	105.8	120.6	84.3	98.4	112.5	77.3	90.6	104.0
	62		TC	121.5	121.5	138.3	113.7	113.7	132.8	108.3	108.3	118.8	98.5	98.5	117.3	90.7	90.7	108.6	
			SHC	97.1	117.7	138.3	92.0	112.4	132.8	82.9	100.8	118.8	79.6	98.5	117.3	72.9	90.7	108.6	
	67		TC	134.0	134.0	134.0	125.3	125.3	125.3	116.2	116.2	116.2	106.9	106.9	106.9	97.3	97.3	99.8	
			SHC	77.1	98.2	119.2	72.4	93.4	114.5	67.6	88.6	109.6	62.8	83.7	104.7	57.9	78.8	99.8	
	72	TC	148.3	148.3	148.3	138.9	138.9	138.9	129.2	129.2	129.2	119.3	119.3	119.3	109.0	109.0	109.0		
		SHC	56.4	77.5	98.7	51.6	72.8	93.9	46.8	68.0	89.1	42.0	63.1	84.1	37.1	58.1	79.2		
	76	TC	—	160.2	160.2	—	150.2	150.2	—	140.0	140.0	—	129.4	129.4	—	118.6	118.6		
		SHC	—	60.8	82.4	—	56.0	77.6	—	51.2	72.7	—	46.3	67.7	—	41.3	62.6		
	4650 cfm	EAT (wb)	58	TC	124.8	124.8	141.5	117.6	117.6	133.7	110.2	110.2	125.5	102.4	102.4	117.0	94.4	94.4	108.1
				SHC	108.2	124.8	141.5	101.6	117.6	133.7	94.9	110.2	125.5	87.8	102.4	117.0	80.6	94.4	108.1
62			TC	127.5	127.5	139.3	117.8	117.8	139.2	110.3	110.3	130.8	102.5	102.5	122.0	94.5	94.5	112.9	
			SHC	99.0	119.1	139.3	96.4	117.8	139.2	89.8	110.3	130.8	83.1	102.5	122.0	76.0	94.5	112.9	
67			TC	136.7	136.7	136.7	127.7	127.7	127.7	118.4	118.4	118.6	108.9	108.9	113.6	99.1	99.1	108.5	
			SHC	81.5	105.0	128.4	76.7	100.2	123.6	71.9	95.3	118.6	67.0	90.3	113.6	62.0	85.3	108.5	
72		TC	151.0	151.0	151.0	141.4	141.4	141.4	131.4	131.4	131.4	121.2	121.2	121.2	110.8	110.8	110.8		
		SHC	58.0	81.6	105.2	53.2	76.8	100.3	48.4	71.9	95.4	43.5	67.0	90.5	38.5	62.0	85.4		
76		TC	—	163.0	163.0	—	152.7	152.7	—	142.2	142.2	—	131.4	131.4	—	—	—		
		SHC	—	62.7	86.7	—	57.9	81.8	—	53.0	76.8	—	48.0	71.8	—	—	—		
5000 cfm		EAT (wb)	58	TC	129.1	129.1	146.3	121.7	121.7	138.1	113.9	113.9	129.6	105.8	105.8	120.8	97.5	97.5	111.6
				SHC	112.0	129.1	146.3	105.2	121.7	138.1	98.2	113.9	129.6	90.9	105.8	120.8	83.4	97.5	111.6
	62		TC	129.3	129.3	152.2	121.8	121.8	143.8	114.0	114.0	135.0	106.0	106.0	125.9	97.6	97.6	116.5	
			SHC	106.3	129.3	152.2	99.8	121.8	143.8	93.0	114.0	135.0	86.0	106.0	125.9	78.7	97.6	116.5	
	67		TC	138.8	138.8	138.8	129.6	129.6	132.4	120.2	120.2	127.4	110.5	110.5	122.2	100.6	100.6	116.9	
			SHC	85.7	111.5	137.3	80.9	106.7	132.4	76.0	101.7	127.4	71.0	96.6	122.2	66.0	91.5	116.9	
	72	TC	153.3	153.3	153.3	143.4	143.4	143.4	133.2	133.2	133.2	122.8	122.8	122.8	112.1	112.1	112.1		
		SHC	59.5	85.5	111.4	54.7	80.6	106.6	49.8	75.7	101.6	44.9	70.8	96.6	39.9	65.7	91.6		
	76	TC	—	165.2	165.2	—	154.7	154.7	—	144.0	144.0	—	—	—	—	—	—		
		SHC	—	64.4	90.8	—	59.5	85.8	—	54.6	80.7	—	—	—	—	—	—		

LEGEND

- Do Not Operate
- cfm — Cubic Feet Per Minute (Supply Air)
- EAT (db) — Entering Air Temperature (dry bulb)
- EAT (wb) — Entering Air Temperature (wet bulb)
- SHC — Sensible Heat Capacity (1000 Btuh) Gross
- TC — Total Capacity (1000 Btuh) Gross

NOTE: See minimum-maximum airflow ratings on page 5.

Performance data (cont)

RHV120 Single Stage Cooling Capacities

RHV120			AMBIENT TEMPERATURE (°F)																
			85			95			105			115			125				
			EAT (db)			EAT (db)			EAT (db)			EAT (db)			EAT (db)				
			75	80	85	75	80	85	75	80	85	75	80	85	75	80	85		
1500 cfm	EAT (wb)	58	TC	51.3	51.3	58.3	48.2	48.2	55.0	45.1	45.1	51.6	41.7	41.7	47.9	38.1	38.1	44.0	
		58	SHC	44.2	51.3	58.3	41.4	48.2	55.0	38.6	45.1	51.6	35.5	41.7	47.9	32.3	38.1	44.0	
		62	TC	55.2	55.2	55.2	51.5	51.5	52.1	47.5	47.5	49.6	43.4	43.4	47.1	39.1	39.1	44.4	
		62	SHC	39.5	46.9	54.4	37.2	44.6	52.1	34.8	42.2	49.6	32.3	39.7	47.1	29.7	37.0	44.4	
		67	TC	61.5	61.5	61.5	57.5	57.5	57.5	53.3	53.3	53.3	48.8	48.8	48.8	44.0	44.0	44.0	
		67	SHC	32.6	40.1	47.6	30.3	37.8	45.3	27.9	35.4	42.8	25.4	32.9	40.4	22.9	30.3	37.8	
	72	TC	68.2	68.2	68.2	64.0	64.0	64.0	59.6	59.6	59.6	54.7	54.7	54.7	49.6	49.6	49.6		
	72	SHC	25.5	33.1	40.7	23.2	30.8	38.4	20.9	28.4	36.0	18.4	25.9	33.5	15.9	23.4	30.9		
	76	TC	—	74.1	74.1	—	69.5	69.5	—	64.8	64.8	—	59.7	59.7	—	54.3	54.3		
	76	SHC	—	27.5	35.7	—	25.2	33.3	—	22.8	30.8	—	20.3	28.3	—	17.8	25.6		
	1750 cfm	EAT (wb)	58	TC	54.6	54.6	62.0	51.4	51.4	58.5	48.0	48.0	54.9	44.4	44.4	50.9	40.5	40.5	46.7
			58	SHC	47.1	54.6	62.0	44.2	51.4	58.5	41.2	48.0	54.9	37.9	44.4	50.9	34.4	40.5	46.7
62			TC	57.3	57.3	60.0	53.4	53.4	57.5	49.3	49.3	54.9	45.1	45.1	52.1	40.6	40.6	48.8	
62			SHC	42.9	51.4	60.0	40.5	49.0	57.5	38.0	46.4	54.9	35.3	43.7	52.1	32.4	40.6	48.8	
67			TC	63.5	63.5	63.5	59.5	59.5	59.5	55.1	55.1	55.1	50.4	50.4	50.4	45.4	45.4	45.4	
67			SHC	34.8	43.4	52.0	32.5	41.1	49.7	30.1	38.6	47.2	27.6	36.1	44.7	24.9	33.5	42.0	
72		TC	70.6	70.6	70.6	66.0	66.0	66.0	61.4	61.4	61.4	56.3	56.3	56.3	50.9	50.9	50.9		
72		SHC	26.6	35.3	44.0	24.3	32.9	41.6	21.9	30.5	39.2	19.3	28.0	36.6	16.7	25.3	33.9		
76		TC	—	76.4	76.4	—	71.7	71.7	—	66.7	66.7	—	61.5	61.5	—	55.8	55.8		
76		SHC	—	28.7	37.9	—	26.4	35.5	—	24.0	33.0	—	21.5	30.4	—	18.8	27.8		
2000 cfm		EAT (wb)	58	TC	57.4	57.4	65.2	54.0	54.0	61.5	50.5	50.5	57.6	46.7	46.7	53.5	42.6	42.6	48.9
			58	SHC	49.7	57.4	65.2	46.6	54.0	61.5	43.4	50.5	57.6	40.0	46.7	53.5	36.2	42.6	48.9
	62		TC	59.1	59.1	65.1	55.0	55.0	62.4	51.6	51.6	56.6	46.7	46.7	55.8	42.8	42.8	51.3	
	62		SHC	46.0	55.6	65.1	43.4	52.9	62.4	39.4	48.0	56.6	37.7	46.7	55.8	34.2	42.8	51.3	
	67		TC	65.3	65.3	65.3	61.0	61.0	61.0	56.4	56.4	56.4	51.6	51.6	51.6	46.4	46.4	46.4	
	67		SHC	36.9	46.6	56.2	34.5	44.2	53.9	32.1	41.7	51.4	29.5	39.2	48.8	26.8	36.5	46.1	
	72	TC	72.3	72.3	72.3	67.6	67.6	67.6	62.8	62.8	62.8	57.6	57.6	57.6	52.1	52.1	52.1		
	72	SHC	27.6	37.3	47.1	25.2	34.9	44.6	22.7	32.5	42.2	20.2	29.9	39.6	17.5	27.2	36.9		
	76	TC	—	78.2	78.2	—	73.4	73.4	—	68.2	68.2	—	62.7	62.7	—	56.9	56.9		
	76	SHC	—	29.8	40.0	—	27.5	37.6	—	25.0	35.1	—	22.5	32.5	—	19.8	29.8		
	2250 cfm	EAT (wb)	58	TC	59.9	59.9	67.9	56.3	56.3	64.1	52.6	52.6	60.0	48.7	48.7	55.7	44.3	44.3	50.9
			58	SHC	51.8	59.9	67.9	48.6	56.3	64.1	45.2	52.6	60.0	41.7	48.7	55.7	37.7	44.3	50.9
62			TC	60.6	60.6	69.6	56.5	56.5	66.8	53.4	53.4	59.5	49.4	49.4	54.6	44.4	44.4	53.1	
62			SHC	48.7	59.1	69.6	46.1	56.5	66.8	41.4	50.4	59.5	37.7	46.2	54.6	35.6	44.4	53.1	
67			TC	66.8	66.8	66.8	62.3	62.3	62.3	57.5	57.5	57.5	52.6	52.6	52.8	47.4	47.4	50.0	
67			SHC	38.9	49.6	60.3	36.5	47.2	57.9	33.9	44.6	55.3	31.4	42.1	52.8	28.7	39.4	50.0	
72		TC	73.7	73.7	73.7	69.0	69.0	69.0	64.0	64.0	64.0	58.6	58.6	58.6	52.9	52.9	52.9		
72		SHC	28.4	39.2	50.0	26.0	36.8	47.6	23.5	34.3	45.0	20.9	31.7	42.4	18.3	29.0	39.7		
76		TC	—	79.7	79.7	—	74.7	74.7	—	69.3	69.3	—	63.8	63.8	—	—	—		
76		SHC	—	30.9	42.1	—	28.4	39.6	—	25.9	37.0	—	23.4	34.4	—	—	—		
2500 cfm		EAT (wb)	58	TC	61.9	61.9	70.2	58.2	58.2	66.1	54.4	54.4	61.9	50.2	50.2	57.4	45.8	45.8	52.5
			58	SHC	53.7	61.9	70.2	50.3	58.2	66.1	46.8	54.4	61.9	43.1	50.2	57.4	39.1	45.8	52.5
	62		TC	62.9	62.9	68.7	59.1	59.1	65.5	54.4	54.4	64.5	50.4	50.4	60.0	45.9	45.9	54.9	
	62		SHC	48.8	58.8	68.7	46.0	55.8	65.5	44.3	54.4	64.5	40.8	50.4	60.0	36.9	45.9	54.9	
	67		TC	68.0	68.0	68.0	63.2	63.2	63.2	58.4	58.4	59.2	53.5	53.5	56.6	48.1	48.1	53.7	
	67		SHC	40.8	52.6	64.3	38.3	50.0	61.8	35.8	47.5	59.2	33.2	44.9	56.6	30.5	42.1	53.7	
	72	TC	74.9	74.9	74.9	70.2	70.2	70.2	65.1	65.1	65.1	59.4	59.4	59.4	53.7	53.7	53.7		
	72	SHC	29.2	41.0	52.8	26.8	38.6	50.4	24.3	36.1	47.9	21.6	33.4	45.2	18.9	30.7	42.4		
	76	TC	—	81.0	81.0	—	75.8	75.8	—	70.5	70.5	—	—	—	—	—	—		
	76	SHC	—	31.8	44.0	—	29.3	41.5	—	26.8	38.9	—	—	—	—	—	—		

LEGEND

- Do Not Operate
- cfm — Cubic Feet Per Minute (Supply Air)
- EAT (db) — Entering Air Temperature (dry bulb)
- EAT (wb) — Entering Air Temperature (wet bulb)
- SHC — Sensible Heat Capacity (1000 Btuh) Gross
- TC — Total Capacity (1000 Btuh) Gross

NOTE: See minimum-maximum airflow ratings on page 5.

Performance data (cont)

RHV150 Two Stage Cooling Capacities

RHV150			AMBIENT TEMPERATURE (°F)																
			85			95			105			115			125				
			EAT (db)			EAT (db)			EAT (db)			EAT (db)			EAT (db)				
			75	80	85	75	80	85	75	80	85	75	80	85	75	80	85		
3750 cfm	EAT (wb)	58	TC	125.4	125.4	143.2	117.1	117.1	134.2	108.4	108.4	124.8	99.3	99.3	115.0	89.8	89.8	104.6	
			SHC	107.7	125.4	143.2	100.0	117.1	134.2	92.0	108.4	124.8	83.7	99.3	115.0	75.0	89.8	104.6	
		62	TC	134.6	134.6	134.6	124.6	124.6	127.6	114.1	114.1	120.8	103.2	103.2	113.8	91.8	91.8	106.3	
			SHC	95.9	115.1	134.2	89.4	108.5	127.6	82.7	101.8	120.8	75.9	94.8	113.8	68.7	87.5	106.3	
		67	TC	150.7	150.7	150.7	140.1	140.1	140.1	129.0	129.0	129.0	117.3	117.3	117.3	105.0	105.0	105.0	
			SHC	78.0	97.2	116.4	71.5	90.7	109.9	64.8	84.0	103.2	58.0	77.2	96.3	51.0	70.1	89.3	
	72	TC	168.1	168.1	168.1	156.9	156.9	156.9	145.1	145.1	145.1	132.8	132.8	132.8	119.7	119.7	119.7		
		SHC	59.8	79.2	98.6	53.3	72.6	92.0	46.6	65.9	85.3	39.7	59.0	78.4	32.7	52.0	71.2		
	76	TC	—	183.0	183.0	—	171.2	171.2	—	158.9	158.9	—	145.9	145.9	—	132.0	132.0		
		SHC	—	64.6	85.0	—	58.0	78.3	—	51.3	71.4	—	44.4	64.4	—	37.3	57.1		
	4400 cfm	EAT (wb)	58	TC	134.2	134.2	152.9	125.4	125.4	143.4	116.3	116.3	133.5	106.6	106.6	123.1	96.5	96.5	112.0
				SHC	115.5	134.2	152.9	107.4	125.4	143.4	99.0	116.3	133.5	90.2	106.6	123.1	81.0	96.5	112.0
62			TC	140.0	140.0	149.2	129.7	129.7	142.3	118.9	118.9	135.1	109.8	109.8	120.0	98.3	98.3	112.2	
			SHC	105.2	127.2	149.2	98.5	120.4	142.3	91.5	113.3	135.1	80.8	100.4	120.0	73.4	92.8	112.2	
67			TC	156.3	156.3	156.3	145.2	145.2	145.2	133.6	133.6	133.6	121.4	121.4	121.4	108.6	108.6	108.6	
			SHC	84.4	106.6	128.9	77.8	100.0	122.2	71.0	93.2	115.4	64.0	86.2	108.4	56.9	79.1	101.3	
72		TC	174.0	174.0	174.0	162.3	162.3	162.3	150.0	150.0	150.0	137.1	137.1	137.1	123.4	123.4	123.4		
		SHC	63.0	85.5	107.9	56.4	78.8	101.2	49.6	72.0	94.3	42.6	65.0	87.3	35.4	57.8	80.1		
76		TC	—	189.0	189.0	—	176.7	176.7	—	163.9	163.9	—	150.3	150.3	—	135.9	135.9		
		SHC	—	68.3	91.5	—	61.7	84.7	—	54.9	77.8	—	47.9	70.7	—	40.6	63.4		
5000 cfm		EAT (wb)	58	TC	141.1	141.1	160.5	131.9	131.9	150.6	122.3	122.3	140.2	112.3	112.3	129.3	101.7	101.7	117.8
				SHC	121.6	141.1	160.5	113.2	131.9	150.6	104.4	122.3	140.2	95.2	112.3	129.3	85.6	101.7	117.8
	62		TC	144.3	144.3	161.9	133.7	133.7	154.3	125.5	125.5	136.0	114.0	114.0	129.8	101.8	101.8	123.3	
			SHC	113.0	137.4	161.9	105.9	130.1	154.3	93.6	114.8	136.0	87.1	108.5	129.8	80.3	101.8	123.3	
	67		TC	160.3	160.3	160.3	148.8	148.8	148.8	136.8	136.8	136.8	124.3	124.3	124.3	111.1	111.1	111.7	
			SHC	89.9	114.8	139.7	83.1	108.0	133.0	76.3	101.2	126.1	69.2	94.1	119.0	62.0	86.8	111.7	
	72	TC	178.1	178.1	178.1	166.0	166.0	166.0	153.4	153.4	153.4	140.1	140.1	140.1	126.0	126.0	126.0		
		SHC	65.7	90.8	115.9	59.0	84.1	109.2	52.1	77.2	102.2	45.0	70.1	95.1	37.8	62.8	87.8		
	76	TC	—	193.3	193.3	—	180.6	180.6	—	167.3	167.3	—	153.4	153.4	—	138.5	138.5		
		SHC	—	71.4	97.2	—	64.7	90.4	—	57.8	83.4	—	50.7	76.3	—	43.4	68.8		
	5650 cfm	EAT (wb)	58	TC	147.5	147.5	167.7	137.9	137.9	157.3	127.9	127.9	146.5	117.5	117.5	135.1	106.4	106.4	123.1
				SHC	127.3	147.5	167.7	118.5	137.9	157.3	109.4	127.9	146.5	99.8	117.5	135.1	89.8	106.4	123.1
62			TC	150.8	150.8	163.5	140.8	140.8	153.7	128.1	128.1	152.9	117.6	117.6	141.2	106.5	106.5	128.8	
			SHC	115.5	139.5	163.5	107.3	130.5	153.7	103.3	128.1	152.9	94.1	117.6	141.2	84.3	106.5	128.8	
67			TC	163.7	163.7	163.7	151.9	151.9	151.9	139.6	139.6	139.6	126.8	126.8	129.9	113.3	113.3	122.3	
			SHC	95.4	123.2	151.0	88.6	116.4	144.2	81.6	109.4	137.1	74.5	102.2	129.9	67.1	94.7	122.3	
72		TC	181.7	181.7	181.7	169.2	169.2	169.2	156.3	156.3	156.3	142.6	142.6	142.6	128.2	128.2	128.2		
		SHC	68.3	96.2	124.2	61.5	89.4	117.4	54.5	82.5	110.4	47.4	75.3	103.2	40.1	67.9	95.8		
76		TC	—	196.9	196.9	—	183.9	183.9	—	170.3	170.3	—	156.0	156.0	—	140.8	140.8		
		SHC	—	74.5	103.1	—	67.7	96.2	—	60.8	89.2	—	53.6	82.0	—	46.2	74.5		
6250 cfm		EAT (wb)	58	TC	152.6	152.6	173.3	142.7	142.7	162.6	132.4	132.4	151.4	121.6	121.6	139.7	110.2	110.2	127.2
				SHC	131.8	152.6	173.3	122.8	142.7	162.6	113.4	132.4	151.4	103.5	121.6	139.7	93.1	110.2	127.2
	62		TC	155.3	155.3	169.9	142.9	142.9	169.5	132.5	132.5	158.0	121.7	121.7	145.9	110.3	110.3	133.1	
			SHC	120.0	145.0	169.9	116.3	142.9	169.5	107.1	132.5	158.0	97.6	121.7	145.9	87.5	110.3	133.1	
	67		TC	166.2	166.2	166.2	154.2	154.2	154.2	141.7	141.7	146.8	128.7	128.7	139.4	115.0	115.0	131.6	
			SHC	100.2	130.6	161.0	93.4	123.7	154.0	86.3	116.6	146.8	79.1	109.2	139.4	71.6	101.6	131.6	
	72	TC	184.3	184.3	184.3	171.7	171.7	171.7	158.4	158.4	158.4	144.6	144.6	144.6	129.8	129.8	129.8		
		SHC	70.5	101.0	131.6	63.6	94.2	124.7	56.7	87.2	117.7	49.5	80.0	110.4	42.1	72.5	103.0		
	76	TC	—	199.7	199.7	—	186.4	186.4	—	172.6	172.6	—	158.0	158.0	—	142.5	142.5		
		SHC	—	77.2	108.4	—	70.3	101.4	—	63.3	94.4	—	56.1	87.1	—	48.6	79.5		

LEGEND

- Do Not Operate
- cfm — Cubic Feet Per Minute (Supply Air)
- EAT (db) — Entering Air Temperature (dry bulb)
- EAT (wb) — Entering Air Temperature (wet bulb)
- SHC — Sensible Heat Capacity (1000 Btuh) Gross
- TC — Total Capacity (1000 Btuh) Gross

NOTE: See minimum-maximum airflow ratings on page 5.

Performance data (cont)

RHV150 Single Stage Cooling Capacities

RHV150			AMBIENT TEMPERATURE (°F)																
			85			95			105			115			125				
			EAT (db)			EAT (db)			EAT (db)			EAT (db)			EAT (db)				
			75	80	85	75	80	85	75	80	85	75	80	85	75	80	85		
2050 cfm	EAT (wb)	58	TC	61.0	61.0	70.5	55.2	55.2	64.4	49.3	49.3	58.1	43.2	43.2	51.6	36.8	36.8	44.8	
		SHC	51.5	61.0	70.5	46.1	55.2	64.4	40.5	49.3	58.1	34.8	43.2	51.6	28.9	36.8	44.8		
		62	TC	66.8	66.8	66.8	60.0	60.0	60.4	52.9	52.9	55.4	45.7	45.7	50.4	38.2	38.2	45.3	
		SHC	45.1	55.2	65.3	40.2	50.3	60.4	35.3	45.4	55.4	30.3	40.4	50.4	25.3	35.3	45.3		
		67	TC	76.6	76.6	76.6	69.4	69.4	69.4	62.1	62.1	62.1	54.4	54.4	54.4	46.5	46.5	46.5	
		SHC	36.0	46.2	56.3	31.0	41.2	51.3	26.0	36.1	46.2	20.8	30.9	41.0	15.5	25.7	35.8		
	72	TC	87.2	87.2	87.2	79.7	79.7	79.7	72.0	72.0	72.0	63.9	63.9	63.9	55.6	55.6	55.6		
	SHC	27.0	37.2	47.4	21.9	32.1	42.3	16.8	27.0	37.1	11.5	21.7	31.9	6.1	16.3	26.5			
	76	TC	—	96.4	96.4	—	88.5	88.5	—	80.4	80.4	—	72.0	72.0	—	63.3	63.3		
	SHC	—	29.9	40.4	—	24.9	35.3	—	19.7	30.1	—	14.4	24.9	—	9.0	19.4			
	2500 cfm	EAT (wb)	58	TC	66.0	66.0	76.0	59.9	59.9	69.6	53.7	53.7	62.9	47.3	47.3	56.1	40.6	40.6	48.9
			SHC	56.0	66.0	76.0	50.3	59.9	69.6	44.5	53.7	62.9	38.5	47.3	56.1	32.2	40.6	48.9	
62			TC	69.8	69.8	73.3	62.7	62.7	68.3	55.5	55.5	63.2	48.1	48.1	57.9	40.7	40.7	51.7	
SHC			50.2	61.8	73.3	45.2	56.8	68.3	40.2	51.7	63.2	35.0	46.5	57.9	29.5	40.6	51.7		
67			TC	79.8	79.8	79.8	72.3	72.3	72.3	64.6	64.6	64.6	56.7	56.7	56.7	48.4	48.4	48.4	
SHC			39.6	51.2	62.8	34.5	46.1	57.7	29.3	40.9	52.6	24.1	35.7	47.3	18.8	30.4	42.0		
72		TC	90.6	90.6	90.6	82.8	82.8	82.8	74.7	74.7	74.7	66.3	66.3	66.3	57.6	57.6	57.6		
SHC		28.9	40.6	52.3	23.7	35.4	47.2	18.5	30.2	41.9	13.2	24.9	36.5	7.7	19.4	31.1			
76		TC	—	99.9	99.9	—	91.7	91.7	—	83.3	83.3	—	74.6	74.6	—	65.5	65.5		
SHC		—	32.1	44.2	—	26.9	39.0	—	21.7	33.6	—	16.3	28.2	—	10.7	22.6			
2900 cfm		EAT (wb)	58	TC	70.3	70.3	80.7	64.0	64.0	74.0	57.5	57.5	67.1	50.7	50.7	59.9	43.7	43.7	52.4
			SHC	59.8	70.3	80.7	53.9	64.0	74.0	47.8	57.5	67.1	41.6	50.7	59.9	35.1	43.7	52.4	
	62		TC	72.4	72.4	80.9	65.1	65.1	75.6	57.8	57.8	70.0	50.8	50.8	63.1	43.8	43.8	55.4	
	SHC		54.9	67.9	80.9	49.8	62.7	75.6	44.5	57.2	70.0	38.6	50.8	63.1	32.2	43.8	55.4		
	67		TC	82.3	82.3	82.3	74.6	74.6	74.6	66.7	66.7	66.7	58.5	58.5	58.5	49.9	49.9	49.9	
	SHC		42.8	56.0	69.1	37.7	50.8	63.9	32.5	45.6	58.7	27.2	40.3	53.4	21.8	34.9	48.0		
	72	TC	93.3	93.3	93.3	85.2	85.2	85.2	76.8	76.8	76.8	68.2	68.2	68.2	59.2	59.2	59.2		
	SHC	30.6	43.8	57.0	25.4	38.6	51.8	20.1	33.2	46.4	14.6	27.8	41.0	9.1	22.3	35.5			
	76	TC	—	102.6	102.6	—	94.2	94.2	—	85.5	85.5	—	76.5	76.5	—	67.2	67.2		
	SHC	—	34.1	47.6	—	28.8	42.3	—	23.4	36.9	—	18.0	31.4	—	12.4	25.7			
	3300 cfm	EAT (wb)	58	TC	74.6	74.6	85.5	68.0	68.0	78.5	61.2	61.2	71.2	54.2	54.2	63.7	46.9	46.9	55.9
			SHC	63.7	74.6	85.5	57.5	68.0	78.5	51.2	61.2	71.2	44.7	54.2	63.7	37.9	46.9	55.9	
62			TC	75.1	75.1	88.7	68.1	68.1	82.0	61.3	61.3	74.7	54.3	54.3	67.1	47.0	47.0	59.1	
SHC			59.9	74.3	88.7	54.1	68.1	82.0	47.9	61.3	74.7	41.5	54.3	67.1	35.0	47.0	59.1		
67			TC	84.7	84.7	84.7	76.7	76.7	76.7	68.6	68.6	68.6	60.1	60.1	60.2	51.4	51.4	54.7	
SHC			46.4	61.2	76.1	41.2	56.0	70.8	35.9	50.7	65.5	30.6	45.4	60.2	25.2	39.9	54.7		
72		TC	95.8	95.8	95.8	87.4	87.4	87.4	78.8	78.8	78.8	69.9	69.9	69.9	60.7	60.7	60.7		
SHC		32.4	47.3	62.2	27.1	42.0	56.9	21.7	36.6	51.5	16.2	31.1	46.0	10.7	25.5	40.4			
76		TC	—	105.2	105.2	—	96.5	96.5	—	87.5	87.5	—	78.3	78.3	—	68.7	68.7		
SHC		—	36.1	51.3	—	30.8	45.9	—	25.3	40.5	—	19.8	34.9	—	14.1	29.2			
3700 cfm		EAT (wb)	58	TC	77.8	77.8	89.0	71.0	71.0	81.8	64.0	64.0	74.3	56.8	56.8	66.6	49.3	49.3	58.5
			SHC	66.5	77.8	89.0	60.2	71.0	81.8	53.7	64.0	74.3	47.0	56.8	66.6	40.0	49.3	58.5	
	62		TC	77.9	77.9	92.9	71.1	71.1	85.5	64.1	64.1	77.9	56.9	56.9	70.0	49.3	49.3	61.7	
	SHC		62.9	77.9	92.9	56.7	71.1	85.5	50.3	64.1	77.9	43.7	56.9	70.0	37.0	49.3	61.7		
	67		TC	86.3	86.3	86.3	78.2	78.2	78.2	69.9	69.9	71.2	61.3	61.3	65.8	52.4	52.4	60.2	
	SHC		49.3	65.6	81.9	44.1	60.3	76.6	38.8	55.0	71.2	33.4	49.6	65.8	27.9	44.1	60.2		
	72	TC	97.5	97.5	97.5	88.9	88.9	88.9	80.2	80.2	80.2	71.1	71.1	71.1	61.7	61.7	61.7		
	SHC	33.8	50.1	66.5	28.4	44.8	61.1	23.0	39.4	55.7	17.5	33.9	50.2	11.9	28.2	44.5			
	76	TC	—	107.0	107.0	—	98.1	98.1	—	88.9	88.9	—	79.6	79.6	—	69.8	69.8		
	SHC	—	37.7	54.4	—	32.3	48.9	—	26.9	43.4	—	21.3	37.8	—	15.6	32.1			

LEGEND

- Do Not Operate
- cfm — Cubic Feet Per Minute (Supply Air)
- EAT (db) — Entering Air Temperature (dry bulb)
- EAT (wb) — Entering Air Temperature (wet bulb)
- SHC — Sensible Heat Capacity (1000 Btuh) Gross
- TC — Total Capacity (1000 Btuh) Gross

NOTE: See minimum-maximum airflow ratings on page 5.

Performance data (cont)

RHV090 Heating Capacities

RHV090 (7.5 Tons)										
Return Air (°F db)	CFM (Standard Air)		Temperature Air Entering Outdoor Coil (°F db at 70% rh)							
			0	10	17	30	40	47	50	60
55	2250	Capacity	34.0	45.1	52.1	65.1	78.0	87.1	90.1	103.3
		Int. Cap.	31.3	41.4	47.5	57.1	78.0	87.1	90.1	103.3
	3000	Capacity	34.7	45.4	53.1	66.7	80.1	89.9	93.2	107.5
		Int. Cap.	31.9	41.7	48.4	58.4	80.1	89.9	93.2	107.5
	3750	Capacity	35.4	46.1	53.8	67.8	81.5	91.6	95.1	110.1
		Int. Cap.	32.5	42.3	49.1	59.4	81.5	91.6	95.1	110.1
70	2250	Capacity	31.5	42.5	48.6	61.5	74.1	82.8	85.6	97.9
		Int. Cap.	29.0	39.0	44.3	53.9	74.1	82.8	85.6	97.9
	3000	Capacity	32.4	43.4	50.1	63.1	76.2	85.6	88.5	102.0
		Int. Cap.	29.8	39.9	45.7	55.3	76.2	85.6	88.5	102.0
	3750	Capacity	33.1	44.1	51.2	64.3	77.6	87.3	90.3	104.7
		Int. Cap.	30.5	40.5	46.7	56.3	77.6	87.3	90.3	104.7
80	2250	Capacity	29.5	40.2	46.9	59.0	71.5	79.9	82.7	94.5
		Int. Cap.	27.1	36.9	42.7	51.7	71.5	79.9	82.7	94.5
	3000	Capacity	30.5	41.2	47.7	60.6	73.5	82.6	85.4	98.3
		Int. Cap.	28.1	37.8	43.5	53.1	73.5	82.6	85.4	98.3
	3750	Capacity	31.4	42.0	48.6	61.8	74.9	84.3	87.3	100.9
		Int. Cap.	28.9	38.6	44.3	54.2	74.9	84.3	87.3	100.9

LEGEND

- Capacity** — Instantaneous Capacity (1000 Btuh) — includes indoor fan motor heat at AHRI static conditions
- Int. Cap.** — Integrated Capacity = instantaneous capacity minus the effects of frost on the OD coil and the heat required to defrost it
- rh** — Relative Humidity
- db** — Dry Bulb

RHV102 Heating Capacities

RHV102 (8.5 Tons)										
Return Air (°F db)	CFM (Standard Air)		Temperature Air Entering Outdoor Coil (°F db at 70% rh)							
			0	10	17	30	40	47	50	60
55	2550	Capacity	35.7	47.7	54.3	68.4	82.9	92.1	95.3	108.9
		Int. Cap.	32.9	43.8	49.5	59.9	82.9	92.1	95.3	108.9
	3400	Capacity	36.9	49.5	55.9	70.9	86.0	95.6	99.2	113.7
		Int. Cap.	34.0	45.4	50.9	62.1	86.0	95.6	99.2	113.7
	4250	Capacity	38.2	50.3	57.3	72.7	88.1	98.2	102.0	117.1
		Int. Cap.	35.1	46.2	52.2	63.7	88.1	98.2	102.0	117.1
70	2550	Capacity	32.7	44.8	51.7	64.5	79.0	87.9	90.8	103.4
		Int. Cap.	30.1	41.1	47.2	56.5	79.0	87.9	90.8	103.4
	3400	Capacity	34.0	46.3	53.2	66.9	81.9	91.4	94.5	108.4
		Int. Cap.	31.3	42.5	48.5	58.6	81.9	91.4	94.5	108.4
	4250	Capacity	35.3	47.7	55.1	68.8	84.0	94.0	97.2	111.8
		Int. Cap.	32.5	43.8	50.2	60.3	84.0	94.0	97.2	111.8
80	2550	Capacity	30.5	43.2	49.2	61.8	76.5	84.9	87.8	99.9
		Int. Cap.	28.0	39.6	44.9	54.1	76.5	84.9	87.8	99.9
	3400	Capacity	31.9	44.3	51.5	64.3	79.3	88.5	91.4	104.4
		Int. Cap.	29.3	40.7	47.0	56.3	79.3	88.5	91.4	104.4
	4250	Capacity	33.3	45.8	52.7	66.2	81.4	91.0	94.1	108.1
		Int. Cap.	30.6	42.0	48.0	58.0	81.4	91.0	94.1	108.1

LEGEND

- Capacity** — Instantaneous Capacity (1000 Btuh) — includes indoor fan motor heat at AHRI static conditions
- Int. Cap.** — Integrated Capacity = instantaneous capacity minus the effects of frost on the OD coil and the heat required to defrost it
- rh** — Relative Humidity
- db** — Dry Bulb

Performance data (cont)

RHV120 Heating Capacities

RHV120 (10 Tons)										
Return Air (°F db)	CFM (Standard Air)		Temperature Air Entering Outdoor Coil (°F db at 70% rh)							
			0	10	17	30	40	47	50	60
55	3000	Capacity	51.4	64.7	72.9	89.6	106.2	116.9	120.4	136.1
		Int. Cap.	47.3	59.4	66.5	78.5	106.2	116.9	120.4	136.1
	4000	Capacity	52.7	67.8	74.5	91.9	108.9	120.3	124.0	140.9
		Int. Cap.	48.5	62.2	67.9	80.5	108.9	120.3	124.0	140.9
	5000	Capacity	54.4	67.7	76.1	94.1	111.3	123.1	126.9	144.6
		Int. Cap.	50.0	62.2	69.4	82.4	111.3	123.1	126.9	144.6
70	3000	Capacity	48.9	63.2	70.5	89.6	103.0	113.1	116.6	131.2
		Int. Cap.	45.0	58.0	64.2	78.5	103.0	113.1	116.6	131.2
	4000	Capacity	50.3	64.6	72.0	88.5	105.6	116.4	120.1	135.8
		Int. Cap.	46.3	59.3	65.7	77.5	105.6	116.4	120.1	135.8
	5000	Capacity	52.2	65.7	73.9	90.7	108.0	119.3	123.0	139.6
		Int. Cap.	48.0	60.3	67.3	79.5	108.0	119.3	123.0	139.6
80	3000	Capacity	47.1	61.1	69.7	84.1	101.0	110.8	114.3	128.2
		Int. Cap.	43.3	56.1	63.5	73.7	101.0	110.8	114.3	128.2
	4000	Capacity	48.6	62.5	71.0	85.1	103.4	113.9	117.5	132.6
		Int. Cap.	44.7	57.4	64.8	74.6	103.4	113.9	117.5	132.6
	5000	Capacity	50.5	64.3	72.2	88.5	105.8	116.7	120.4	136.4
		Int. Cap.	46.5	59.0	65.8	77.5	105.8	116.7	120.4	136.4

LEGEND

- Capacity** — Instantaneous Capacity (1000 Btuh) — includes indoor fan motor heat at AHRI static conditions
- Int. Cap.** — Integrated Capacity = instantaneous capacity minus the effects of frost on the OD coil and the heat required to defrost it
- rh** — Relative Humidity
- db** — Dry Bulb

RHV150 Heating Capacities

RHV150 (12.5 Tons)										
Return Air (°F db)	CFM (Standard Air)		Temperature Air Entering Outdoor Coil (°F db at 70% rh)							
			0	10	17	30	40	47	50	60
55	3750	Capacity	49.4	66.6	76.9	97.3	117.6	130.8	135.5	154.5
		Int. Cap.	45.5	61.2	70.1	85.2	117.6	130.8	135.5	154.5
	5000	Capacity	52.4	69.6	80.3	102.0	123.1	137.5	142.6	163.3
		Int. Cap.	48.2	63.9	73.2	89.4	123.1	137.5	142.6	163.3
	6250	Capacity	54.3	72.5	83.3	105.9	127.5	142.3	147.7	169.5
		Int. Cap.	49.9	66.5	76.0	92.8	127.5	142.3	147.7	169.5
70	3750	Capacity	43.3	60.7	70.4	89.6	109.8	122.4	126.9	144.8
		Int. Cap.	39.9	55.7	64.2	78.5	109.8	122.4	126.9	144.8
	5000	Capacity	46.2	63.7	73.9	94.5	115.3	128.9	133.7	153.2
		Int. Cap.	42.5	58.4	67.3	82.8	115.3	128.9	133.7	153.2
	6250	Capacity	48.4	66.6	77.0	98.4	119.7	133.8	138.8	159.3
		Int. Cap.	44.5	61.1	70.2	86.2	119.7	133.8	138.8	159.3
80	3750	Capacity	38.9	56.2	65.9	84.6	104.6	116.8	121.1	138.3
		Int. Cap.	35.8	51.6	60.1	74.1	104.6	116.8	121.1	138.3
	5000	Capacity	41.9	59.2	69.4	89.2	110.0	123.2	127.7	146.4
		Int. Cap.	38.6	54.3	63.2	78.2	110.0	123.2	127.7	146.4
	6250	Capacity	44.0	62.2	72.6	93.2	114.4	128.1	132.9	152.6
		Int. Cap.	40.5	57.1	66.2	81.7	114.4	128.1	132.9	152.6

LEGEND

- Capacity** — Instantaneous Capacity (1000 Btuh) — includes indoor fan motor heat at AHRI static conditions
- Int. Cap.** — Integrated Capacity = instantaneous capacity minus the effects of frost on the OD coil and the heat required to defrost it
- rh** — Relative Humidity
- db** — Dry Bulb

Performance data (cont)

Pressure Drop for Electric Heating Units

7.5 to 10 Ton Units

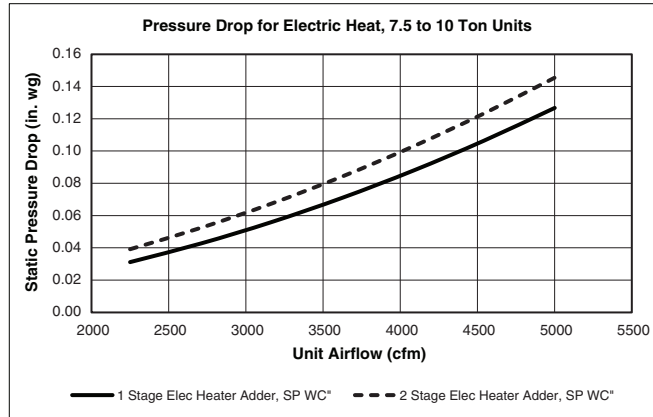

12.5 Ton Units

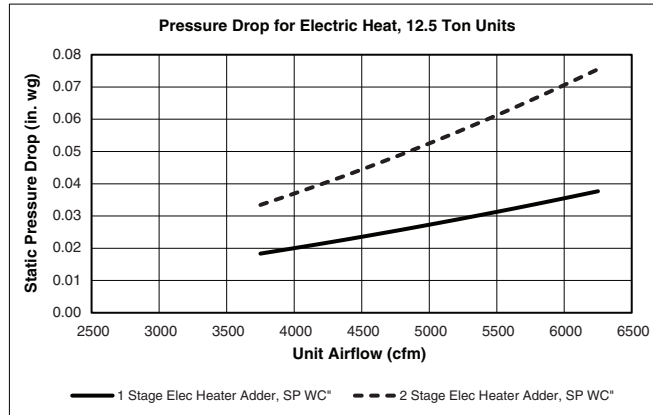

Performance data (cont)

Economizer Barometric Relief and Damper Leakage — 7.5 to 10 Ton Units

Horizontal Economizer Barometric Relief

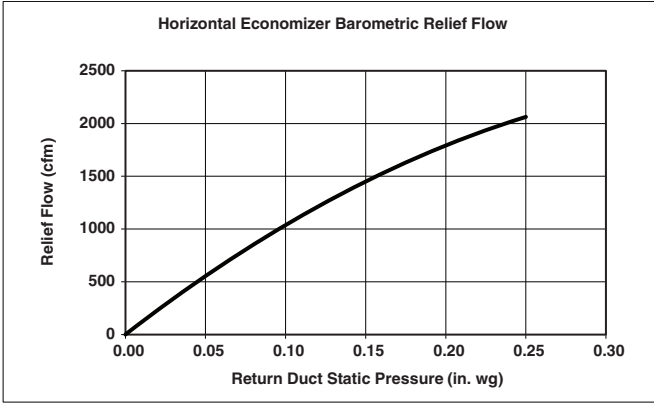

Vertical Economizer Barometric Relief

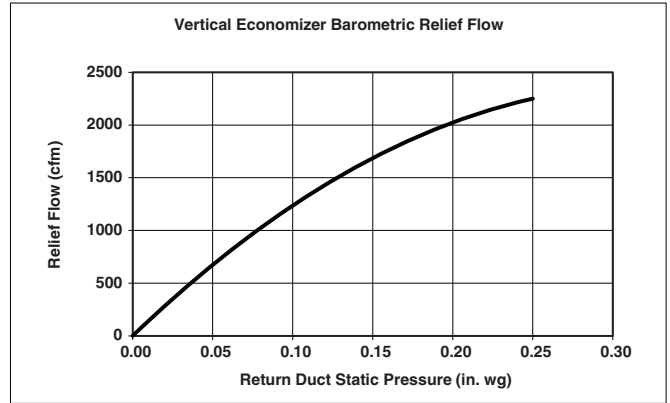

Horizontal Economizer Damper Leakage

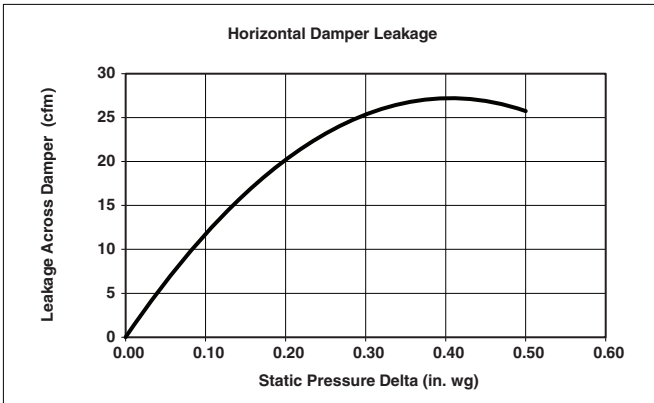

Vertical Economizer Damper Leakage

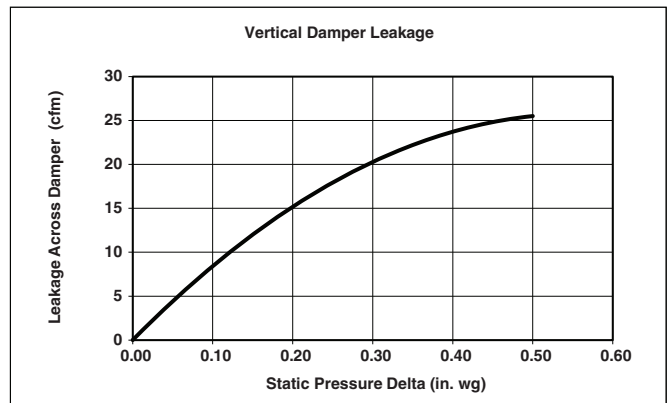

Performance data (cont)

Economizer Barometric Relief and Damper Leakage — 12.5 Ton Units

Horizontal Economizer Barometric Relief

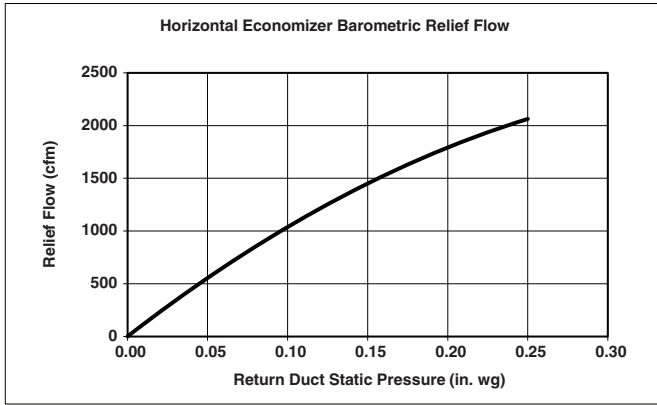

Vertical Economizer Barometric Relief

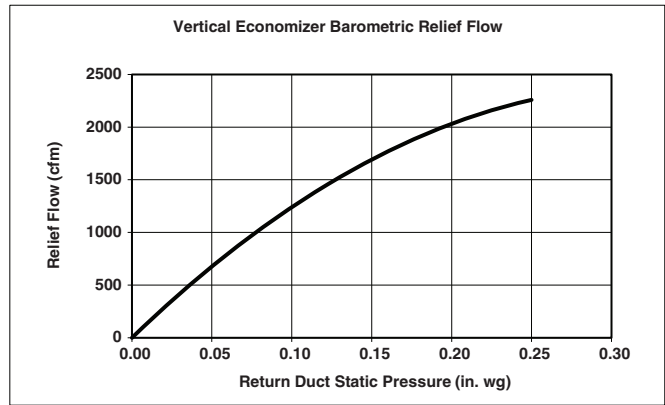

Horizontal Economizer Damper Leakage

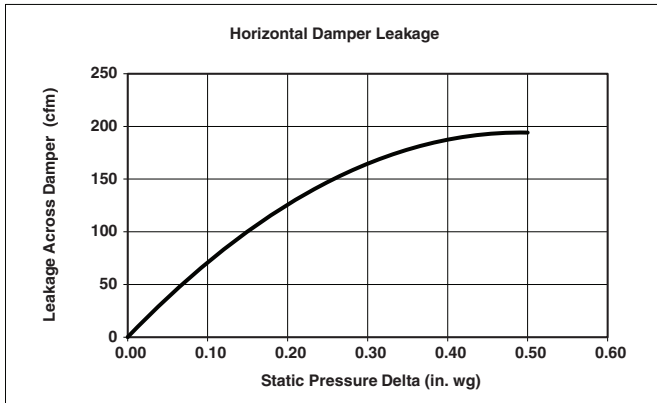

Vertical Economizer Damper Leakage

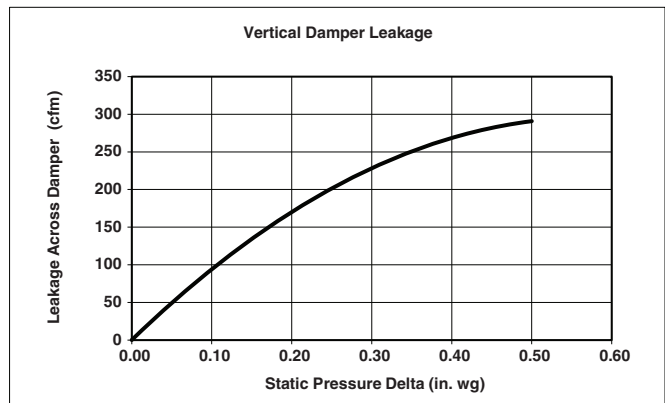

Economizer Pressure Drop

7.5 to 10 Ton Units

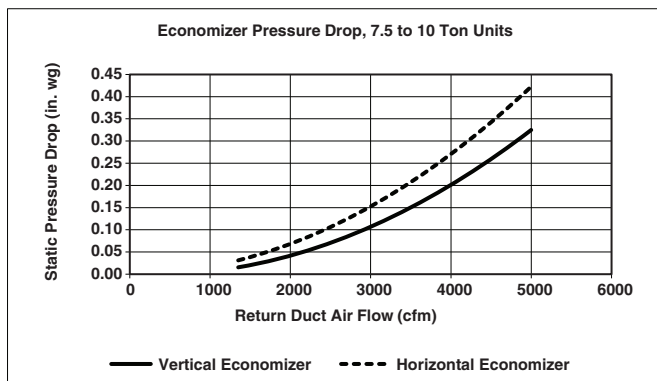

12.5 Ton Units

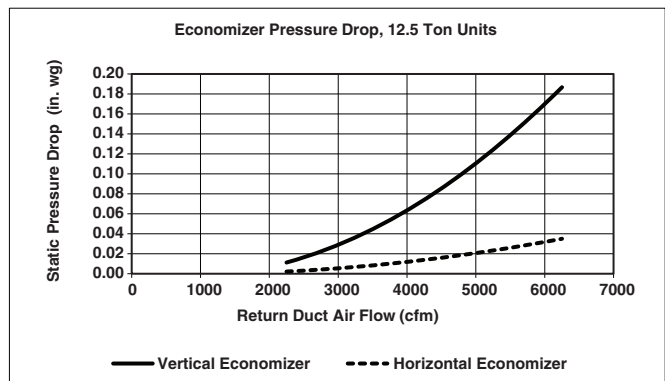

Fan data

General Fan Performance Notes

1. Interpolation is permissible. Do not extrapolate.
2. External static pressure is the static pressure difference between the return duct and the supply duct plus the static pressure caused by any FIOPs or accessories.
3. Tabular data accounts for pressure loss due to clean filters, unit casing, wet coils, and highest gas heat exchanger (when gas heat unit).
4. Factory options and accessories may effect static pressure losses. Gas heat unit fan tables assume highest gas heat models; for fan selections with low or medium heat models, the user must deduct low and medium heat static pressures. Selection software is available, through your salesperson, to help you select the best motor/drive combination for your application.
5. The fan performance tables offer motor/drive recommendations. In cases when 2 motor/drive combinations would work, the lower horsepower option is recommended.
6. For information on the electrical properties of the fan motors, please see the Electrical information section of this book.
7. For more information on the performance limits of the fan motors, see the application data section of this book.
8. The EPACT (Energy Policy Act of 1992) regulates energy requirements for specific types of indoor fan motors. Motors regulated by EPACT include any general purpose, T-frame (3-digit, 143 and larger), single-speed, foot mounted, polyphase, squirrel cage induction motors of NEMA (National Electrical Manufacturers Association) design A and B, manufactured for use in the United States. Ranging from 1 to 200 Hp, these continuous-duty motors operate on 230 and 460 volt, 60 Hz power. If a motor does not fit into these specifications, the motor does not have to be replaced by an EPACT compliant energy-efficient motor. Variable-speed motors are exempt from EPACT compliance requirements.

Fan data (cont)

RHV090 — 7.5 Ton Vertical Supply (rpm - bhp)

CFM	AVAILABLE EXTERNAL STATIC PRESSURE (in. wg)									
	0.2		0.4		0.6		0.8		1.0	
	rpm	bhp	rpm	bhp	rpm	bhp	rpm	bhp	rpm	bhp
2250	920	0.29	1045	0.43	1158	0.58	1262	0.75	1356	0.93
2440	980	0.35	1097	0.49	1205	0.65	1304	0.82	1397	1.01
2625	1039	0.41	1150	0.56	1252	0.72	1348	0.90	1438	1.09
2815	1101	0.49	1205	0.64	1303	0.81	1396	0.99	1482	1.19
3000	1163	0.57	1261	0.72	1355	0.90	1443	1.08	1527	1.28
3190	1226	0.66	1320	0.82	1409	1.00	1494	1.19	1575	1.39
3375	1289	0.75	1378	0.92	1463	1.10	1545	1.30	1623	1.51
3565	1354	0.86	1438	1.03	1520	1.22	1598	1.42	1674	1.63
3750	1417	0.97	1498	1.15	1576	1.33	1651	1.53	1724	1.75

CFM	AVAILABLE EXTERNAL STATIC PRESSURE (in. wg)									
	1.2		1.4		1.6		1.8		2.0	
	rpm	bhp	rpm	bhp	rpm	bhp	rpm	bhp	rpm	bhp
2250	1444	1.12	1527	1.33	1604	1.54	1678	1.76	1748	1.99
2440	1483	1.21	1564	1.42	1640	1.63	1713	1.86	1782	2.10
2625	1522	1.30	1602	1.51	1677	1.73	1748	1.96	1817	2.20
2815	1565	1.40	1642	1.61	1716	1.84	1786	2.08	1853	2.32
3000	1607	1.50	1683	1.72	1755	1.95	1824	2.19	1891	2.44
3190	1652	1.61	1727	1.84	1797	2.07	1865	2.31	1930	2.57
3375	1698	1.72	1770	1.95	1839	2.19	1906	2.44	1970	2.69
3565	1746	1.85	1816	2.08	1884	2.32	1949	2.57	2012	2.83
3750	1795	1.97	1863	2.20	1929	2.45	1993	2.70	2055	2.96

Std/Med Static 920-2000 rpm, 2.4 Max bhp

High Static 920-2200 rpm, 3.0 Max bhp

RHV090 — Standard/Medium Static — 7.5 Ton Vertical Supply (rpm - Vdc)

CFM	AVAILABLE EXTERNAL STATIC PRESSURE (in. wg)									
	0.2		0.4		0.6		0.8		1.0	
	rpm	Vdc	rpm	Vdc	rpm	Vdc	rpm	Vdc	rpm	Vdc
2250	920	4.4	1045	5.1	1158	5.7	1262	6.2	1356	6.7
2440	980	4.8	1097	5.4	1205	5.9	1304	6.4	1397	6.9
2625	1039	5.1	1150	5.6	1252	6.2	1348	6.6	1438	7.1
2815	1101	5.4	1205	5.9	1303	6.4	1396	6.9	1482	7.3
3000	1163	5.7	1261	6.2	1355	6.7	1443	7.1	1527	7.6
3190	1226	6.0	1320	6.5	1409	7.0	1494	7.4	1575	7.8
3375	1289	6.3	1378	6.8	1463	7.2	1545	7.7	1623	8.1
3565	1354	6.7	1438	7.1	1520	7.5	1598	7.9	1674	8.3
3750	1417	7.0	1498	7.4	1576	7.8	1651	8.2	1724	8.6

CFM	AVAILABLE EXTERNAL STATIC PRESSURE (in. wg)									
	1.2		1.4		1.6		1.8		2.0	
	rpm	Vdc	rpm	Vdc	rpm	Vdc	rpm	Vdc	rpm	Vdc
2250	1444	7.1	1527	7.6	1604	8.0	1678	8.3	1748	8.7
2440	1483	7.3	1564	7.8	1640	8.1	1713	8.5	1782	8.9
2625	1522	7.5	1602	8.0	1677	8.3	1748	8.7	1817	9.1
2815	1565	7.8	1642	8.2	1716	8.5	1786	8.9	1853	9.2
3000	1607	8.0	1683	8.4	1755	8.7	1824	9.1	1891	9.4
3190	1652	8.2	1727	8.6	1797	9.0	1865	9.3	—	—
3375	1698	8.4	1770	8.8	1839	9.2	1906	9.5	—	—
3565	1746	8.7	1816	9.1	1884	9.4	—	—	—	—
3750	1795	8.9	1863	9.3	1929	9.6	—	—	—	—

Std/Med Static 920-2000 rpm

Fan data (cont)

RHV090 — High Static — 7.5 Ton Vertical Supply (rpm - Vdc)

CFM	AVAILABLE EXTERNAL STATIC PRESSURE (in. wg)									
	0.2		0.4		0.6		0.8		1.0	
	rpm	Vdc	rpm	Vdc	rpm	Vdc	rpm	Vdc	rpm	Vdc
2250	920	4.1	1045	4.7	1158	5.2	1262	5.7	1356	6.1
2440	980	4.4	1097	4.9	1205	5.4	1304	5.9	1397	6.3
2625	1039	4.6	1150	5.2	1252	5.6	1348	6.1	1438	6.5
2815	1101	4.9	1205	5.4	1303	5.9	1396	6.3	1482	6.7
3000	1163	5.2	1261	5.7	1355	6.1	1443	6.5	1527	6.9
3190	1226	5.5	1320	5.9	1409	6.3	1494	6.7	1575	7.1
3375	1289	5.8	1378	6.2	1463	6.6	1545	7.0	1623	7.3
3565	1354	6.1	1438	6.5	1520	6.9	1598	7.2	1674	7.6
3750	1417	6.4	1498	6.8	1576	7.1	1651	7.5	1724	7.8

CFM	AVAILABLE EXTERNAL STATIC PRESSURE (in. wg)									
	1.2		1.4		1.6		1.8		2.0	
	rpm	Vdc	rpm	Vdc	rpm	Vdc	rpm	Vdc	rpm	Vdc
2250	1444	6.5	1527	6.9	1604	7.2	1678	7.6	1748	7.9
2440	1483	6.7	1564	7.1	1640	7.4	1713	7.8	1782	8.1
2625	1522	6.9	1602	7.2	1677	7.6	1748	7.9	1817	8.2
2815	1565	7.1	1642	7.4	1716	7.8	1786	8.1	1853	8.4
3000	1607	7.3	1683	7.6	1755	7.9	1824	8.3	1891	8.6
3190	1652	7.5	1727	7.8	1797	8.1	1865	8.5	1930	8.8
3375	1698	7.7	1770	8.0	1839	8.3	1906	8.6	1970	8.9
3565	1746	7.9	1816	8.2	1884	8.5	1949	8.8	2012	9.1
3750	1795	8.1	1863	8.4	1929	8.7	1993	9.0	2055	9.3

High Static 920-2200 rpm

Fan data (cont)

RHV102 — 8.5 Ton Vertical Supply (rpm - bhp)

CFM	AVAILABLE EXTERNAL STATIC PRESSURE (in. wg)									
	0.2		0.4		0.6		0.8		1.0	
	rpm	bhp	rpm	bhp	rpm	bhp	rpm	bhp	rpm	bhp
2550	1035	0.41	1147	0.56	1251	0.73	1348	0.91	1438	1.11
2765	1104	0.50	1209	0.65	1308	0.83	1401	1.02	1488	1.22
2975	1173	0.59	1272	0.76	1365	0.93	1454	1.13	1538	1.34
3190	1244	0.70	1337	0.87	1426	1.06	1511	1.26	1592	1.47
3400	1314	0.82	1402	0.99	1487	1.19	1568	1.39	1646	1.61
3615	1387	0.95	1470	1.13	1551	1.33	1629	1.54	1703	1.76
3825	1458	1.09	1538	1.28	1615	1.48	1689	1.69	1761	1.92
4040	1532	1.24	1608	1.44	1681	1.64	1752	1.86	1822	2.09
4250	1605	1.41	1677	1.60	1747	1.81	1815	2.03	1882	2.27

CFM	AVAILABLE EXTERNAL STATIC PRESSURE (in. wg)									
	1.2		1.4		1.6		1.8		2.0	
	rpm	bhp	rpm	bhp	rpm	bhp	rpm	bhp	rpm	bhp
2550	522	1.32	1602	1.53	1677	1.76	1749	2.00	1817	2.24
2765	1570	1.43	1647	1.65	1721	1.89	1792	2.13	1859	2.38
2975	1618	1.56	1693	1.78	1766	2.02	1835	2.27	1901	2.52
3190	1669	1.69	1743	1.93	1813	2.17	1881	2.42	1946	2.68
3400	1721	1.84	1792	2.07	1861	2.32	1927	2.58	1991	2.84
3615	1776	2.00	1845	2.24	1912	2.49	1976	2.75	2039	3.02
3825	1831	2.16	1898	2.40	1963	2.66	2026	2.92	2087	3.20
4040	1889	2.33	1954	2.58	2017	2.84	2078	3.11	—	—
4250	1947	2.51	2010	2.76	2071	3.02	—	—	—	—

Std/Med Static 1035-2000 rpm, 2.4 Max bhp

High Static 1035-2200 rpm, 3.0 Max bhp

RHV102 — Standard/Medium Static — 8.5 Ton Vertical Supply (rpm - Vdc)

CFM	AVAILABLE EXTERNAL STATIC PRESSURE (in. wg)									
	0.2		0.4		0.6		0.8		1.0	
	rpm	Vdc	rpm	Vdc	rpm	Vdc	rpm	Vdc	rpm	Vdc
2550	1035	5.0	1147	5.6	1251	6.1	1348	6.6	1438	7.1
2765	1104	5.4	1209	5.9	1308	6.4	1401	6.9	1488	7.4
2975	1173	5.7	1272	6.3	1365	6.7	1454	7.2	1538	7.6
3190	1244	6.1	1337	6.6	1426	7.0	1511	7.5	1592	7.9
3400	1314	6.5	1402	6.9	1487	7.4	1568	7.8	1646	8.2
3615	1387	6.8	1470	7.3	1551	7.7	1629	8.1	1703	8.5
3825	1458	7.2	1538	7.6	1615	8.0	1689	8.4	1761	8.8
4040	1532	7.6	1608	8.0	1681	8.4	1752	8.7	1822	9.1
4250	1605	8.0	1677	8.3	1747	8.7	1815	9.0	1882	9.4

CFM	AVAILABLE EXTERNAL STATIC PRESSURE (in. wg)									
	1.2		1.4		1.6		1.8		2.0	
	rpm	Vdc	rpm	Vdc	rpm	Vdc	rpm	Vdc	rpm	Vdc
2550	1522	7.5	1602	8.0	1677	8.3	1749	8.7	1817	9.1
2765	1570	7.8	1647	8.2	1721	8.6	1792	8.9	1859	9.3
2975	1618	8.0	1693	8.4	1766	8.8	1835	9.2	1901	9.5
3190	1669	8.3	1743	8.7	1813	9.0	1881	9.4	—	—
3400	1721	8.6	1792	8.9	1861	9.3	—	—	—	—
3615	1776	8.8	1845	9.2	1912	9.5	—	—	—	—
3825	1831	9.1	1898	9.5	—	—	—	—	—	—
4040	1889	9.4	—	—	—	—	—	—	—	—
4250	1947	9.7	—	—	—	—	—	—	—	—

Std/Med Static 1035-2000 rpm

Fan data (cont)

RHV102 — High Static — 8.5 Ton Vertical Supply (rpm - Vdc)

CFM	AVAILABLE EXTERNAL STATIC PRESSURE (in. wg)									
	0.2		0.4		0.6		0.8		1.0	
	rpm	Vdc	rpm	Vdc	rpm	Vdc	rpm	Vdc	rpm	Vdc
2550	1035	4.6	1147	5.1	1251	5.6	1348	6.1	1438	6.5
2765	1104	4.9	1209	5.4	1308	5.9	1401	6.3	1488	6.7
2975	1173	5.3	1272	5.7	1365	6.1	1454	6.6	1538	6.9
3190	1244	5.6	1337	6.0	1426	6.4	1511	6.8	1592	7.2
3400	1314	5.9	1402	6.3	1487	6.7	1568	7.1	1646	7.4
3615	1387	6.2	1470	6.6	1551	7.0	1629	7.4	1703	7.7
3825	1458	6.6	1538	6.9	1615	7.3	1689	7.6	1761	8.0
4040	1532	6.9	1608	7.3	1681	7.6	1752	7.9	1822	8.3
4250	1605	7.3	1677	7.6	1747	7.9	1815	8.2	1882	8.5

CFM	AVAILABLE EXTERNAL STATIC PRESSURE (in. wg)									
	1.2		1.4		1.6		1.8		2.0	
	rpm	Vdc	rpm	Vdc	rpm	Vdc	rpm	Vdc	rpm	Vdc
2550	1522	6.9	1602	7.2	1677	7.6	1749	7.9	1817	8.2
2765	1570	7.1	1647	7.4	1721	7.8	1792	8.1	1859	8.4
2975	1618	7.3	1693	7.7	1766	8.0	1835	8.3	1901	8.6
3190	1669	7.5	1743	7.9	1813	8.2	1881	8.5	1946	8.8
3400	1721	7.8	1792	8.1	1861	8.4	1927	8.7	1991	9.0
3615	1776	8.0	1845	8.4	1912	8.7	1976	9.0	2039	9.3
3825	1831	8.3	1898	8.6	1963	8.9	2026	9.2	2087	9.5
4040	1889	8.6	1954	8.9	2017	9.2	2078	9.4	—	—
4250	1947	8.8	2010	9.1	2071	9.4	—	—	—	—

High Static 1035-2200 rpm

Fan data (cont)

RHV120 — 10 Ton Vertical Supply (rpm - bhp)

CFM	AVAILABLE EXTERNAL STATIC PRESSURE (in. wg)									
	0.2		0.4		0.6		0.8		1.0	
	rpm	bhp	rpm	bhp	rpm	bhp	rpm	bhp	rpm	bhp
3000	990	0.36	1116	0.51	1224	0.67	1320	0.84	1406	1.02
3250	1052	0.42	1172	0.58	1277	0.76	1371	0.94	1456	1.12
3500	1115	0.50	1229	0.67	1331	0.85	1423	1.03	1506	1.22
3750	1179	0.58	1287	0.75	1386	0.94	1476	1.14	1558	1.34
4000	1243	0.67	1347	0.85	1442	1.04	1529	1.24	1610	1.45
4250	1309	0.76	1407	0.95	1499	1.14	1584	1.35	1663	1.56
4500	1376	0.86	1469	1.05	1557	1.25	1640	1.46	1717	1.68
4750	1443	0.97	1532	1.16	1617	1.36	1697	1.57	1772	1.79
5000	1511	1.07	1595	1.26	1677	1.47	1755	1.68	1828	1.90

CFM	AVAILABLE EXTERNAL STATIC PRESSURE (in. wg)									
	1.2		1.4		1.6		1.8		2.0	
	rpm	bhp	rpm	bhp	rpm	bhp	rpm	bhp	rpm	bhp
3000	1486	1.20	1561	1.40	1632	1.59	1701	1.81	1765	2.02
3250	1534	1.31	1608	1.51	1678	1.71	1744	1.93	1808	2.15
3500	1583	1.42	1656	1.63	1724	1.84	1790	2.06	1852	2.28
3750	1634	1.54	1705	1.75	1772	1.97	1837	2.19	1898	2.42
4000	1685	1.66	1755	1.88	1822	2.10	1885	2.33	1945	2.55
4250	1737	1.78	1806	2.00	1872	2.23	1934	2.46	1994	2.69
4500	1790	1.90	1858	2.13	1923	2.36	1984	2.59	2043	2.83
4750	1843	2.01	1910	2.24	1974	2.47	2035	2.71	2093	2.95
5000	1898	2.13	1964	2.36	2027	2.59	2087	2.83	2144	3.07

Std/Med Static 990-2000 rpm, 2.4 Max bhp

High Static 990-2200 rpm, 5.0 Max bhp

RHV120 — Standard/Medium Static — 10 Ton Vertical Supply (rpm - Vdc)

CFM	AVAILABLE EXTERNAL STATIC PRESSURE (in. wg)									
	0.2		0.4		0.6		0.8		1.0	
	rpm	Vdc	rpm	Vdc	rpm	Vdc	rpm	Vdc	rpm	Vdc
3000	990	4.8	1116	5.5	1224	6.0	1320	6.5	1406	6.9
3250	1052	5.1	1172	5.7	1277	6.3	1371	6.8	1456	7.2
3500	1115	5.4	1229	6.0	1331	6.6	1423	7.0	1506	7.5
3750	1179	5.8	1287	6.3	1386	6.8	1476	7.3	1558	7.7
4000	1243	6.1	1347	6.6	1442	7.1	1529	7.6	1610	8.0
4250	1309	6.4	1407	7.0	1499	7.4	1584	7.9	1663	8.3
4500	1376	6.8	1469	7.3	1557	7.7	1640	8.1	1717	8.5
4750	1443	7.1	1532	7.6	1617	8.0	1697	8.4	1772	8.8
5000	1511	7.5	1595	7.9	1677	8.3	1755	8.7	1828	9.1

CFM	AVAILABLE EXTERNAL STATIC PRESSURE (in. wg)									
	1.2		1.4		1.6		1.8		2.0	
	rpm	Vdc	rpm	Vdc	rpm	Vdc	rpm	Vdc	rpm	Vdc
3000	1486	7.4	1561	7.7	1632	8.1	1701	8.5	1765	8.8
3250	1534	7.6	1608	8.0	1678	8.3	1744	8.7	1808	9.0
3500	1583	7.9	1656	8.2	1724	8.6	1790	8.9	1852	9.2
3750	1634	8.1	1705	8.5	1772	8.8	1837	9.2	1898	9.5
4000	1685	8.4	1755	8.7	1822	9.1	1885	9.4	—	—
4250	1737	8.6	1806	9.0	1872	9.3	1934	9.7	—	—
4500	1790	8.9	1858	9.3	1923	9.6	—	—	—	—
4750	1843	9.2	1910	9.5	1974	9.9	—	—	—	—
5000	1898	9.5	1964	9.8	—	—	—	—	—	—

Std/Med Static 990-2000 rpm

Fan data (cont)

RHV120 — High Static — 10 Ton Vertical Supply (rpm - Vdc)

CFM	AVAILABLE EXTERNAL STATIC PRESSURE (in. wg)									
	0.2		0.4		0.6		0.8		1.0	
	rpm	Vdc	rpm	Vdc	rpm	Vdc	rpm	Vdc	rpm	Vdc
3000	990	4.4	1116	5.0	1224	5.5	1320	5.9	1406	6.3
3250	1052	4.7	1172	5.3	1277	5.7	1371	6.2	1456	6.6
3500	1115	5.0	1229	5.5	1331	6.0	1423	6.4	1506	6.8
3750	1179	5.3	1287	5.8	1386	6.2	1476	6.7	1558	7.0
4000	1243	5.6	1347	6.1	1442	6.5	1529	6.9	1610	7.3
4250	1309	5.9	1407	6.3	1499	6.8	1584	7.2	1663	7.5
4500	1376	6.2	1469	6.6	1557	7.0	1640	7.4	1717	7.8
4750	1443	6.5	1532	6.9	1617	7.3	1697	7.7	1772	8.0
5000	1511	6.8	1595	7.2	1677	7.6	1755	7.9	1828	8.3

CFM	AVAILABLE EXTERNAL STATIC PRESSURE (in. wg)									
	1.2		1.4		1.6		1.8		2.0	
	rpm	Vdc	rpm	Vdc	rpm	Vdc	rpm	Vdc	rpm	Vdc
3000	1486	6.7	1561	7.1	1632	7.4	1701	7.7	1765	8.0
3250	1534	6.9	1608	7.3	1678	7.6	1744	7.9	1808	8.2
3500	1583	7.2	1656	7.5	1724	7.8	1790	8.1	1852	8.4
3750	1634	7.4	1705	7.7	1772	8.0	1837	8.3	1898	8.6
4000	1685	7.6	1755	7.9	1822	8.3	1885	8.5	1945	8.8
4250	1737	7.9	1806	8.2	1872	8.5	1934	8.8	1994	9.0
4500	1790	8.1	1858	8.4	1923	8.7	1984	9.0	2043	9.3
4750	1843	8.4	1910	8.7	1974	9.0	2035	9.2	2093	9.5
5000	1898	8.6	1964	8.9	2027	9.2	2087	9.5	2144	9.7

High Static 990-2200 rpm

Fan data (cont)

RHV150 — 12.5 Ton Vertical Supply (rpm - bhp)

CFM	AVAILABLE EXTERNAL STATIC PRESSURE (in. wg)									
	0.2		0.4		0.6		0.8		1.0	
	rpm	bhp	rpm	bhp	rpm	bhp	rpm	bhp	rpm	bhp
3750	947	0.45	1044	0.60	1140	0.78	1236	0.99	1329	1.23
4065	1019	0.55	1108	0.71	1197	0.90	1286	1.11	1373	1.36
4375	1091	0.68	1174	0.85	1257	1.04	1339	1.26	1421	1.50
4690	1164	0.82	1242	1.00	1319	1.20	1396	1.42	1473	1.67
5000	1237	0.98	1310	1.16	1383	1.37	1455	1.60	1527	1.85
5315	1312	1.16	1381	1.35	1449	1.56	1517	1.79	1585	2.05
5625	1387	1.36	1452	1.56	1516	1.77	1580	2.00	1645	2.26
5940	1463	1.57	1524	1.77	1585	2.00	1646	2.23	1707	2.49
6250	1537	1.79	1596	2.01	1654	2.23	1712	2.48	1770	2.74

CFM	AVAILABLE EXTERNAL STATIC PRESSURE (in. wg)									
	1.2		1.4		1.6		1.8		2.0	
	rpm	bhp	rpm	bhp	rpm	bhp	rpm	bhp	rpm	bhp
3750	1419	1.50	1506	1.79	1589	2.11	1668	2.44	1743	2.78
4065	1459	1.63	1542	1.92	1622	2.24	1699	2.57	1773	2.92
4375	1502	1.77	1581	2.07	1658	2.38	1732	2.72	1805	3.08
4690	1549	1.94	1624	2.23	1698	2.55	1769	2.88	1839	3.24
5000	1599	2.12	1670	2.41	1740	2.73	1809	3.07	1877	3.43
5315	1653	2.32	1721	2.62	1787	2.93	1853	3.27	1918	3.63
5625	1709	2.54	1773	2.83	1836	3.14	1899	3.48	1961	3.83
5940	1768	2.77	1829	3.07	1889	3.38	1949	3.71	2008	4.06
6250	1828	3.01	1886	3.31	1943	3.62	2001	3.95	2057	4.29

Std/Med Static 947-2000 rpm, 3.0 Max bhp

High Static 947-2200 rpm, 5.0 Max bhp

RHV150 — Standard/Medium Static — 12.5 Ton Vertical Supply (rpm - Vdc)

CFM	AVAILABLE EXTERNAL STATIC PRESSURE (in. wg)									
	0.2		0.4		0.6		0.8		1.0	
	rpm	Vdc	rpm	Vdc	rpm	Vdc	rpm	Vdc	rpm	Vdc
3750	947	4.2	1044	4.7	1140	5.1	1236	5.6	1329	6.0
4065	1019	4.5	1108	5.0	1197	5.4	1286	5.8	1373	6.2
4375	1091	4.9	1174	5.3	1257	5.6	1339	6.0	1421	6.4
4690	1164	5.2	1242	5.6	1319	5.9	1396	6.3	1473	6.6
5000	1237	5.6	1310	5.9	1383	6.2	1455	6.6	1527	6.9
5315	1312	5.9	1381	6.2	1449	6.5	1517	6.8	1585	7.2
5625	1387	6.2	1452	6.5	1516	6.8	1580	7.1	1645	7.4
5940	1463	6.6	1524	6.9	1585	7.2	1646	7.4	1707	7.7
6250	1537	6.9	1596	7.2	1654	7.5	1712	7.7	1770	8.0

CFM	AVAILABLE EXTERNAL STATIC PRESSURE (in. wg)									
	1.2		1.4		1.6		1.8		2.0	
	rpm	Vdc	rpm	Vdc	rpm	Vdc	rpm	Vdc	rpm	Vdc
3750	1419	6.4	1506	6.8	1589	7.2	1668	7.5	1743	7.9
4065	1459	6.6	1542	7.0	1622	7.3	1699	7.7	1773	8.0
4375	1502	6.8	1581	7.1	1658	7.5	1732	7.8	1805	8.2
4690	1549	7.0	1624	7.3	1698	7.7	1769	8.0	—	—
5000	1599	7.2	1670	7.6	1740	7.9	1809	8.2	—	—
5315	1653	7.5	1721	7.8	1787	8.1	—	—	—	—
5625	1709	7.7	1773	8.0	1836	8.3	—	—	—	—
5940	1768	8.0	1829	8.3	—	—	—	—	—	—
6250	1828	8.3	—	—	—	—	—	—	—	—

Std/Med Static 947-2000 rpm

Fan data (cont)

RHV150 — High Static — 12.5 Ton Vertical Supply (rpm - Vdc)

CFM	AVAILABLE EXTERNAL STATIC PRESSURE (in. wg)									
	0.2		0.4		0.6		0.8		1.0	
	rpm	Vdc	rpm	Vdc	rpm	Vdc	rpm	Vdc	rpm	Vdc
3750	947	4.2	1044	4.7	1140	5.1	1236	5.6	1329	6.0
4065	1019	4.5	1108	5.0	1197	5.4	1286	5.8	1373	6.2
4375	1091	4.9	1174	5.3	1257	5.6	1339	6.0	1421	6.4
4690	1164	5.2	1242	5.6	1319	5.9	1396	6.3	1473	6.6
5000	1237	5.6	1310	5.9	1383	6.2	1455	6.6	1527	6.9
5315	1312	5.9	1381	6.2	1449	6.5	1517	6.8	1585	7.2
5625	1387	6.2	1452	6.5	1516	6.8	1580	7.1	1645	7.4
5940	1463	6.6	1524	6.9	1585	7.2	1646	7.4	1707	7.7
6250	1537	6.9	1596	7.2	1654	7.5	1712	7.7	1770	8.0

CFM	AVAILABLE EXTERNAL STATIC PRESSURE (in. wg)									
	1.2		1.4		1.6		1.8		2.0	
	rpm	Vdc	rpm	Vdc	rpm	Vdc	rpm	Vdc	rpm	Vdc
3750	1419	6.4	1506	6.8	1589	7.2	1668	7.5	1743	7.9
4065	1459	6.6	1542	7.0	1622	7.3	1699	7.7	1773	8.0
4375	1502	6.8	1581	7.1	1658	7.5	1732	7.8	1805	8.2
4690	1549	7.0	1624	7.3	1698	7.7	1769	8.0	1839	8.3
5000	1599	7.2	1670	7.6	1740	7.9	1809	8.2	1877	8.5
5315	1653	7.5	1721	7.8	1787	8.1	1853	8.4	1918	8.7
5625	1709	7.7	1773	8.0	1836	8.3	1899	8.6	1961	8.9
5940	1768	8.0	1829	8.3	1889	8.6	1949	8.8	2008	9.1
6250	1828	8.3	1886	8.6	1943	8.8	2001	9.1	2057	9.3

High Static 947-2200 rpm,

Fan data (cont)

RHV090 — 7.5 Ton Horizontal Supply (rpm - bhp)

CFM	AVAILABLE EXTERNAL STATIC PRESSURE (in. wg)									
	0.2		0.4		0.6		0.8		1.0	
	rpm	bhp	rpm	bhp	rpm	bhp	rpm	bhp	rpm	bhp
2250	920	0.29	1045	0.43	1158	0.58	1262	0.75	1356	0.93
2440	980	0.35	1097	0.49	1205	0.65	1304	0.82	1397	1.01
2625	1039	0.41	1150	0.56	1252	0.72	1348	0.90	1438	1.09
2815	1101	0.49	1205	0.64	1303	0.81	1396	0.99	1482	1.19
3000	1163	0.57	1261	0.72	1355	0.90	1443	1.08	1527	1.28
3190	1226	0.66	1320	0.82	1409	1.00	1494	1.19	1575	1.39
3375	1289	0.75	1378	0.92	1463	1.10	1545	1.30	1623	1.51
3565	1354	0.86	1438	1.03	1520	1.22	1598	1.42	1674	1.63
3750	1417	0.97	1498	1.15	1576	1.33	1651	1.53	1724	1.75

CFM	AVAILABLE EXTERNAL STATIC PRESSURE (in. wg)									
	1.2		1.4		1.6		1.8		2.0	
	rpm	bhp	rpm	bhp	rpm	bhp	rpm	bhp	rpm	bhp
2250	1444	1.12	1527	1.33	1604	1.54	1678	1.76	1748	1.99
2440	1483	1.21	1564	1.42	1640	1.63	1713	1.86	1782	2.10
2625	1522	1.30	1602	1.51	1677	1.73	1748	1.96	1817	2.20
2815	1565	1.40	1642	1.61	1716	1.84	1786	2.08	1853	2.32
3000	1607	1.50	1683	1.72	1755	1.95	1824	2.19	1891	2.44
3190	1652	1.61	1727	1.84	1797	2.07	1865	2.31	1930	2.57
3375	1698	1.72	1770	1.95	1839	2.19	1906	2.44	1970	2.69
3565	1746	1.85	1816	2.08	1884	2.32	1949	2.57	2012	2.83
3750	1795	1.97	1863	2.20	1929	2.45	1993	2.70	2055	2.96

Std/Med Static 920-2000 rpm, 2.4 Max bhp

High Static 920-2200 rpm, 3.0 Max bhp

RHV090 — Standard/Medium Static — 7.5 Ton Horizontal Supply (rpm - Vdc)

CFM	AVAILABLE EXTERNAL STATIC PRESSURE (in. wg)									
	0.2		0.4		0.6		0.8		1.0	
	rpm	Vdc	rpm	Vdc	rpm	Vdc	rpm	Vdc	rpm	Vdc
2250	920	4.4	1045	5.1	1158	5.7	1262	6.2	1356	6.7
2440	980	4.8	1097	5.4	1205	5.9	1304	6.4	1397	6.9
2625	1039	5.1	1150	5.6	1252	6.2	1348	6.6	1438	7.1
2815	1101	5.4	1205	5.9	1303	6.4	1396	6.9	1482	7.3
3000	1163	5.7	1261	6.2	1355	6.7	1443	7.1	1527	7.6
3190	1226	6.0	1320	6.5	1409	7.0	1494	7.4	1575	7.8
3375	1289	6.3	1378	6.8	1463	7.2	1545	7.7	1623	8.1
3565	1354	6.7	1438	7.1	1520	7.5	1598	7.9	1674	8.3
3750	1417	7.0	1498	7.4	1576	7.8	1651	8.2	1724	8.6

CFM	AVAILABLE EXTERNAL STATIC PRESSURE (in. wg)									
	1.2		1.4		1.6		1.8		2.0	
	rpm	Vdc	rpm	Vdc	rpm	Vdc	rpm	Vdc	rpm	Vdc
2250	1444	7.1	1527	7.6	1604	8.0	1678	8.3	1748	8.7
2440	1483	7.3	1564	7.8	1640	8.1	1713	8.5	1782	8.9
2625	1522	7.5	1602	8.0	1677	8.3	1748	8.7	1817	9.1
2815	1565	7.8	1642	8.2	1716	8.5	1786	8.9	1853	9.2
3000	1607	8.0	1683	8.4	1755	8.7	1824	9.1	1891	9.4
3190	1652	8.2	1727	8.6	1797	9.0	1865	9.3	—	—
3375	1698	8.4	1770	8.8	1839	9.2	1906	9.5	—	—
3565	1746	8.7	1816	9.1	1884	9.4	—	—	—	—
3750	1795	8.9	1863	9.3	1929	9.6	—	—	—	—

Std/Med Static 920-2000 rpm

Fan data (cont)

RHV090 — High Static — 7.5 Ton Horizontal Supply (rpm - Vdc)

CFM	AVAILABLE EXTERNAL STATIC PRESSURE (in. wg)									
	0.2		0.4		0.6		0.8		1.0	
	rpm	Vdc	rpm	Vdc	rpm	Vdc	rpm	Vdc	rpm	Vdc
2250	920	4.1	1045	4.7	1158	5.2	1262	5.7	1356	6.1
2440	980	4.4	1097	4.9	1205	5.4	1304	5.9	1397	6.3
2625	1039	4.6	1150	5.2	1252	5.6	1348	6.1	1438	6.5
2815	1101	4.9	1205	5.4	1303	5.9	1396	6.3	1482	6.7
3000	1163	5.2	1261	5.7	1355	6.1	1443	6.5	1527	6.9
3190	1226	5.5	1320	5.9	1409	6.3	1494	6.7	1575	7.1
3375	1289	5.8	1378	6.2	1463	6.6	1545	7.0	1623	7.3
3565	1354	6.1	1438	6.5	1520	6.9	1598	7.2	1674	7.6
3750	1417	6.4	1498	6.8	1576	7.1	1651	7.5	1724	7.8

CFM	AVAILABLE EXTERNAL STATIC PRESSURE (in. wg)									
	1.2		1.4		1.6		1.8		2.0	
	rpm	Vdc	rpm	Vdc	rpm	Vdc	rpm	Vdc	rpm	Vdc
2250	1444	6.5	1527	6.9	1604	7.2	1678	7.6	1748	7.9
2440	1483	6.7	1564	7.1	1640	7.4	1713	7.8	1782	8.1
2625	1522	6.9	1602	7.2	1677	7.6	1748	7.9	1817	8.2
2815	1565	7.1	1642	7.4	1716	7.8	1786	8.1	1853	8.4
3000	1607	7.3	1683	7.6	1755	7.9	1824	8.3	1891	8.6
3190	1652	7.5	1727	7.8	1797	8.1	1865	8.5	1930	8.8
3375	1698	7.7	1770	8.0	1839	8.3	1906	8.6	1970	8.9
3565	1746	7.9	1816	8.2	1884	8.5	1949	8.8	2012	9.1
3750	1795	8.1	1863	8.4	1929	8.7	1993	9.0	2055	9.3

High Static 920-2200 rpm

Fan data (cont)

RHV102 — 8.5 Ton Horizontal Supply (rpm - bhp)

CFM	AVAILABLE EXTERNAL STATIC PRESSURE (in. wg)									
	0.2		0.4		0.6		0.8		1.0	
	rpm	bhp	rpm	bhp	rpm	bhp	rpm	bhp	rpm	bhp
2550	1035	0.41	1147	0.56	1251	0.73	1348	0.91	1438	1.11
2765	1104	0.50	1209	0.65	1308	0.83	1401	1.02	1488	1.22
2975	1173	0.59	1272	0.76	1365	0.93	1454	1.13	1538	1.34
3190	1244	0.70	1337	0.87	1426	1.06	1511	1.26	1592	1.47
3400	1314	0.82	1402	0.99	1487	1.19	1568	1.39	1646	1.61
3615	1387	0.95	1470	1.13	1551	1.33	1629	1.54	1703	1.76
3825	1458	1.09	1538	1.28	1615	1.48	1689	1.69	1761	1.92
4040	1532	1.24	1608	1.44	1681	1.64	1752	1.86	1822	2.09
4250	1605	1.41	1677	1.60	1747	1.81	1815	2.03	1882	2.27

CFM	AVAILABLE EXTERNAL STATIC PRESSURE (in. wg)									
	1.2		1.4		1.6		1.8		2.0	
	rpm	bhp	rpm	bhp	rpm	bhp	rpm	bhp	rpm	bhp
2550	1522	1.32	1602	1.53	1677	1.76	1749	2.00	1817	2.24
2765	1570	1.43	1647	1.65	1721	1.89	1792	2.13	1859	2.38
2975	1618	1.56	1693	1.78	1766	2.02	1835	2.27	1901	2.52
3190	1669	1.69	1743	1.93	1813	2.17	1881	2.42	1946	2.68
3400	1721	1.84	1792	2.07	1861	2.32	1927	2.58	1991	2.84
3615	1776	2.00	1845	2.24	1912	2.49	1976	2.75	2039	3.02
3825	1831	2.16	1898	2.40	1963	2.66	2026	2.92	2087	3.20
4040	1889	2.33	1954	2.58	2017	2.84	2078	3.11	—	—
4250	1947	2.51	2010	2.76	2071	3.02	—	—	—	—

Std/Med Static 1035-2000 rpm, 2.4 Max bhp

High Static 1035-2200 rpm, 3.0 Max bhp

RHV102 — Standard/Medium Static — 8.5 Ton Horizontal Supply (rpm - Vdc)

CFM	AVAILABLE EXTERNAL STATIC PRESSURE (in. wg)									
	0.2		0.4		0.6		0.8		1.0	
	rpm	Vdc	rpm	Vdc	rpm	Vdc	rpm	Vdc	rpm	Vdc
2550	1035	5.0	1147	5.6	1251	6.1	1348	6.6	1438	7.1
2765	1104	5.4	1209	5.9	1308	6.4	1401	6.9	1488	7.4
2975	1173	5.7	1272	6.3	1365	6.7	1454	7.2	1538	7.6
3190	1244	6.1	1337	6.6	1426	7.0	1511	7.5	1592	7.9
3400	1314	6.5	1402	6.9	1487	7.4	1568	7.8	1646	8.2
3615	1387	6.8	1470	7.3	1551	7.7	1629	8.1	1703	8.5
3825	1458	7.2	1538	7.6	1615	8.0	1689	8.4	1761	8.8
4040	1532	7.6	1608	8.0	1681	8.4	1752	8.7	1822	9.1
4250	1605	8.0	1677	8.3	1747	8.7	1815	9.0	1882	9.4

CFM	AVAILABLE EXTERNAL STATIC PRESSURE (in. wg)									
	1.2		1.4		1.6		1.8		2.0	
	rpm	Vdc	rpm	Vdc	rpm	Vdc	rpm	Vdc	rpm	Vdc
2550	1522	7.5	1602	8.0	1677	8.3	1749	8.7	1817	9.1
2765	1570	7.8	1647	8.2	1721	8.6	1792	8.9	1859	9.3
2975	1618	8.0	1693	8.4	1766	8.8	1835	9.2	1901	9.5
3190	1669	8.3	1743	8.7	1813	9.0	1881	9.4	—	—
3400	1721	8.6	1792	8.9	1861	9.3	—	—	—	—
3615	1776	8.8	1845	9.2	1912	9.5	—	—	—	—
3825	1831	9.1	1898	9.5	—	—	—	—	—	—
4040	1889	9.4	—	—	—	—	—	—	—	—
4250	1947	9.7	—	—	—	—	—	—	—	—

Std/Med Static 1035-2000 rpm

Fan data (cont)

RHV102 — High Static — 8.5 Ton Horizontal Supply (rpm - Vdc)

CFM	AVAILABLE EXTERNAL STATIC PRESSURE (in. wg)									
	0.2		0.4		0.6		0.8		1.0	
	rpm	Vdc	rpm	Vdc	rpm	Vdc	rpm	Vdc	rpm	Vdc
2550	1035	4.6	1147	5.1	1251	5.6	1348	6.1	1438	6.5
2765	1104	4.9	1209	5.4	1308	5.9	1401	6.3	1488	6.7
2975	1173	5.3	1272	5.7	1365	6.1	1454	6.6	1538	6.9
3190	1244	5.6	1337	6.0	1426	6.4	1511	6.8	1592	7.2
3400	1314	5.9	1402	6.3	1487	6.7	1568	7.1	1646	7.4
3615	1387	6.2	1470	6.6	1551	7.0	1629	7.4	1703	7.7
3825	1458	6.6	1538	6.9	1615	7.3	1689	7.6	1761	8.0
4040	1532	6.9	1608	7.3	1681	7.6	1752	7.9	1822	8.3
4250	1605	7.3	1677	7.6	1747	7.9	1815	8.2	1882	8.5

CFM	AVAILABLE EXTERNAL STATIC PRESSURE (in. wg)									
	1.2		1.4		1.6		1.8		2.0	
	rpm	Vdc	rpm	Vdc	rpm	Vdc	rpm	Vdc	rpm	Vdc
2550	1522	6.9	1602	7.2	1677	7.6	1749	7.9	1817	8.2
2765	1570	7.1	1647	7.4	1721	7.8	1792	8.1	1859	8.4
2975	1618	7.3	1693	7.7	1766	8.0	1835	8.3	1901	8.6
3190	1669	7.5	1743	7.9	1813	8.2	1881	8.5	1946	8.8
3400	1721	7.8	1792	8.1	1861	8.4	1927	8.7	1991	9.0
3615	1776	8.0	1845	8.4	1912	8.7	1976	9.0	2039	9.3
3825	1831	8.3	1898	8.6	1963	8.9	2026	9.2	2087	9.5
4040	1889	8.6	1954	8.9	2017	9.2	2078	9.4	—	—
4250	1947	8.8	2010	9.1	2071	9.4	—	—	—	—

High Static 1035-2200 rpm

Fan data (cont)

RHV120 — 10 Ton Horizontal Supply (rpm - bhp)

CFM	AVAILABLE EXTERNAL STATIC PRESSURE (in. wg)									
	0.2		0.4		0.6		0.8		1.0	
	rpm	bhp	rpm	bhp	rpm	bhp	rpm	bhp	rpm	bhp
3000	990	0.36	1116	0.51	1224	0.67	1320	0.84	1406	1.02
3250	1052	0.42	1172	0.58	1277	0.76	1371	0.94	1456	1.12
3500	1115	0.50	1229	0.67	1331	0.85	1423	1.03	1506	1.22
3750	1179	0.58	1287	0.75	1386	0.94	1476	1.14	1558	1.34
4000	1243	0.67	1347	0.85	1442	1.04	1529	1.24	1610	1.45
4250	1309	0.76	1407	0.95	1499	1.14	1584	1.35	1663	1.56
4500	1376	0.86	1469	1.05	1557	1.25	1640	1.46	1717	1.68
4750	1443	0.97	1532	1.16	1617	1.36	1697	1.57	1772	1.79
5000	1511	1.07	1595	1.26	1677	1.47	1755	1.68	1828	1.90

CFM	AVAILABLE EXTERNAL STATIC PRESSURE (in. wg)									
	1.2		1.4		1.6		1.8		2.0	
	rpm	bhp	rpm	bhp	rpm	bhp	rpm	bhp	rpm	bhp
3000	1486	1.20	1561	1.40	1632	1.59	1701	1.81	1765	2.02
3250	1534	1.31	1608	1.51	1678	1.71	1744	1.93	1808	2.15
3500	1583	1.42	1656	1.63	1724	1.84	1790	2.06	1852	2.28
3750	1634	1.54	1705	1.75	1772	1.97	1837	2.19	1898	2.42
4000	1685	1.66	1755	1.88	1822	2.10	1885	2.33	1945	2.55
4250	1737	1.78	1806	2.00	1872	2.23	1934	2.46	1994	2.69
4500	1790	1.90	1858	2.13	1923	2.36	1984	2.59	2043	2.83
4750	1843	2.01	1910	2.24	1974	2.47	2035	2.71	2093	2.95
5000	1898	2.13	1964	2.36	2027	2.59	2087	2.83	2144	3.07

Std/Med Static 990-2000 rpm, 2.4 Max bhp

High Static 990-2200 rpm, 5.0 Max bhp

RHV120 — Standard/Medium Static — 10 Ton Horizontal Supply (rpm - Vdc)

CFM	AVAILABLE EXTERNAL STATIC PRESSURE (in. wg)									
	0.2		0.4		0.6		0.8		1.0	
	rpm	Vdc	rpm	Vdc	rpm	Vdc	rpm	Vdc	rpm	Vdc
3000	990	4.8	1116	5.5	1224	6.0	1320	6.5	1406	6.9
3250	1052	5.1	1172	5.7	1277	6.3	1371	6.8	1456	7.2
3500	1115	5.4	1229	6.0	1331	6.6	1423	7.0	1506	7.5
3750	1179	5.8	1287	6.3	1386	6.8	1476	7.3	1558	7.7
4000	1243	6.1	1347	6.6	1442	7.1	1529	7.6	1610	8.0
4250	1309	6.4	1407	7.0	1499	7.4	1584	7.9	1663	8.3
4500	1376	6.8	1469	7.3	1557	7.7	1640	8.1	1717	8.5
4750	1443	7.1	1532	7.6	1617	8.0	1697	8.4	1772	8.8
5000	1511	7.5	1595	7.9	1677	8.3	1755	8.7	1828	9.1

CFM	AVAILABLE EXTERNAL STATIC PRESSURE (in. wg)									
	1.2		1.4		1.6		1.8		2.0	
	rpm	Vdc	rpm	Vdc	rpm	Vdc	rpm	Vdc	rpm	Vdc
3000	1486	7.4	1561	7.7	1632	8.1	1701	8.5	1765	8.8
3250	1534	7.6	1608	8.0	1678	8.3	1744	8.7	1808	9.0
3500	1583	7.9	1656	8.2	1724	8.6	1790	8.9	1852	9.2
3750	1634	8.1	1705	8.5	1772	8.8	1837	9.2	1898	9.5
4000	1685	8.4	1755	8.7	1822	9.1	1885	9.4	—	—
4250	1737	8.6	1806	9.0	1872	9.3	1934	9.7	—	—
4500	1790	8.9	1858	9.3	1923	9.6	—	—	—	—
4750	1843	9.2	1910	9.5	1974	9.9	—	—	—	—
5000	1898	9.5	1964	9.8	—	—	—	—	—	—

Std/Med Static 990-2000 rpm

Fan data (cont)

RHV120 — High Static — 10 Ton Horizontal Supply (rpm - Vdc)

CFM	AVAILABLE EXTERNAL STATIC PRESSURE (in. wg)									
	0.2		0.4		0.6		0.8		1.0	
	rpm	Vdc	rpm	Vdc	rpm	Vdc	rpm	Vdc	rpm	Vdc
3000	990	4.4	1116	5.0	1224	5.5	1320	5.9	1406	6.3
3250	1052	4.7	1172	5.3	1277	5.7	1371	6.2	1456	6.6
3500	1115	5.0	1229	5.5	1331	6.0	1423	6.4	1506	6.8
3750	1179	5.3	1287	5.8	1386	6.2	1476	6.7	1558	7.0
4000	1243	5.6	1347	6.1	1442	6.5	1529	6.9	1610	7.3
4250	1309	5.9	1407	6.3	1499	6.8	1584	7.2	1663	7.5
4500	1376	6.2	1469	6.6	1557	7.0	1640	7.4	1717	7.8
4750	1443	6.5	1532	6.9	1617	7.3	1697	7.7	1772	8.0
5000	1511	6.8	1595	7.2	1677	7.6	1755	7.9	1828	8.3

CFM	AVAILABLE EXTERNAL STATIC PRESSURE (in. wg)									
	1.2		1.4		1.6		1.8		2.0	
	rpm	Vdc	rpm	Vdc	rpm	Vdc	rpm	Vdc	rpm	Vdc
3000	1486	6.7	1561	7.1	1632	7.4	1701	7.7	1765	8.0
3250	1534	6.9	1608	7.3	1678	7.6	1744	7.9	1808	8.2
3500	1583	7.2	1656	7.5	1724	7.8	1790	8.1	1852	8.4
3750	1634	7.4	1705	7.7	1772	8.0	1837	8.3	1898	8.6
4000	1685	7.6	1755	7.9	1822	8.3	1885	8.5	1945	8.8
4250	1737	7.9	1806	8.2	1872	8.5	1934	8.8	1994	9.0
4500	1790	8.1	1858	8.4	1923	8.7	1984	9.0	2043	9.3
4750	1843	8.4	1910	8.7	1974	9.0	2035	9.2	2093	9.5
5000	1898	8.6	1964	8.9	2027	9.2	2087	9.5	2144	9.7

High Static 990-2200 rpm

Fan data (cont)

RHV150 — 12.5 Ton Horizontal Supply (rpm - bhp)

CFM	AVAILABLE EXTERNAL STATIC PRESSURE (in. wg)									
	0.2		0.4		0.6		0.8		1.0	
	rpm	bhp	rpm	bhp	rpm	bhp	rpm	bhp	rpm	bhp
3750	947	0.45	1044	0.60	1140	0.78	1236	0.99	1329	1.23
4065	1019	0.55	1108	0.71	1197	0.90	1286	1.11	1373	1.36
4375	1091	0.68	1174	0.85	1257	1.04	1339	1.26	1421	1.50
4690	1164	0.82	1242	1.00	1319	1.20	1396	1.42	1473	1.67
5000	1237	0.98	1310	1.16	1383	1.37	1455	1.60	1527	1.85
5315	1312	1.16	1381	1.35	1449	1.56	1517	1.79	1585	2.05
5625	1387	1.36	1452	1.56	1516	1.77	1580	2.00	1645	2.26
5940	1463	1.57	1524	1.77	1585	2.00	1646	2.23	1707	2.49
6250	1537	1.79	1596	2.01	1654	2.23	1712	2.48	1770	2.74

CFM	AVAILABLE EXTERNAL STATIC PRESSURE (in. wg)									
	1.2		1.4		1.6		1.8		2.0	
	rpm	bhp	rpm	bhp	rpm	bhp	rpm	bhp	rpm	bhp
3750	1419	1.50	1506	1.79	1589	2.11	1668	2.44	1743	2.78
4065	1459	1.63	1542	1.92	1622	2.24	1699	2.57	1773	2.92
4375	1502	1.77	1581	2.07	1658	2.38	1732	2.72	1805	3.08
4690	1549	1.94	1624	2.23	1698	2.55	1769	2.88	1839	3.24
5000	1599	2.12	1670	2.41	1740	2.73	1809	3.07	1877	3.43
5315	1653	2.32	1721	2.62	1787	2.93	1853	3.27	1918	3.63
5625	1709	2.54	1773	2.83	1836	3.14	1899	3.48	1961	3.83
5940	1768	2.77	1829	3.07	1889	3.38	1949	3.71	2008	4.06
6250	1828	3.01	1886	3.31	1943	3.62	2001	3.95	2057	4.29

Std/Med Static 947-2000 rpm, 3.0 Max bhp

High Static 947-2200 rpm, 5.0 Max bhp

RHV150 — Standard/Medium Static — 12.5 Ton Horizontal Supply (rpm - Vdc)

CFM	AVAILABLE EXTERNAL STATIC PRESSURE (in. wg)									
	0.2		0.4		0.6		0.8		1.0	
	rpm	Vdc	rpm	Vdc	rpm	Vdc	rpm	Vdc	rpm	Vdc
3750	947	4.2	1044	4.7	1140	5.1	1236	5.6	1329	6.0
4065	1019	4.5	1108	5.0	1197	5.4	1286	5.8	1373	6.2
4375	1091	4.9	1174	5.3	1257	5.6	1339	6.0	1421	6.4
4690	1164	5.2	1242	5.6	1319	5.9	1396	6.3	1473	6.6
5000	1237	5.6	1310	5.9	1383	6.2	1455	6.6	1527	6.9
5315	1312	5.9	1381	6.2	1449	6.5	1517	6.8	1585	7.2
5625	1387	6.2	1452	6.5	1516	6.8	1580	7.1	1645	7.4
5940	1463	6.6	1524	6.9	1585	7.2	1646	7.4	1707	7.7
6250	1537	6.9	1596	7.2	1654	7.5	1712	7.7	1770	8.0

CFM	AVAILABLE EXTERNAL STATIC PRESSURE (in. wg)									
	1.2		1.4		1.6		1.8		2.0	
	rpm	Vdc	rpm	Vdc	rpm	Vdc	rpm	Vdc	rpm	Vdc
3750	1419	6.4	1506	6.8	1589	7.2	1668	7.5	1743	7.9
4065	1459	6.6	1542	7.0	1622	7.3	1699	7.7	1773	8.0
4375	1502	6.8	1581	7.1	1658	7.5	1732	7.8	1805	8.2
4690	1549	7.0	1624	7.3	1698	7.7	1769	8.0	—	—
5000	1599	7.2	1670	7.6	1740	7.9	1809	8.2	—	—
5315	1653	7.5	1721	7.8	1787	8.1	—	—	—	—
5625	1709	7.7	1773	8.0	1836	8.3	—	—	—	—
5940	1768	8.0	1829	8.3	—	—	—	—	—	—
6250	1828	8.3	—	—	—	—	—	—	—	—

Std/Med Static 947-2000 rpm

Fan data (cont)

RHV150 — High Static — 12.5 Ton Horizontal Supply (rpm - Vdc)

CFM	AVAILABLE EXTERNAL STATIC PRESSURE (in. wg)									
	0.2		0.4		0.6		0.8		1.0	
	rpm	Vdc	rpm	Vdc	rpm	Vdc	rpm	Vdc	rpm	Vdc
3750	947	4.2	1044	4.7	1140	5.1	1236	5.6	1329	6.0
4065	1019	4.5	1108	5.0	1197	5.4	1286	5.8	1373	6.2
4375	1091	4.9	1174	5.3	1257	5.6	1339	6.0	1421	6.4
4690	1164	5.2	1242	5.6	1319	5.9	1396	6.3	1473	6.6
5000	1237	5.6	1310	5.9	1383	6.2	1455	6.6	1527	6.9
5315	1312	5.9	1381	6.2	1449	6.5	1517	6.8	1585	7.2
5625	1387	6.2	1452	6.5	1516	6.8	1580	7.1	1645	7.4
5940	1463	6.6	1524	6.9	1585	7.2	1646	7.4	1707	7.7
6250	1537	6.9	1596	7.2	1654	7.5	1712	7.7	1770	8.0

CFM	AVAILABLE EXTERNAL STATIC PRESSURE (in. wg)									
	1.2		1.4		1.6		1.8		2.0	
	rpm	Vdc	rpm	Vdc	rpm	Vdc	rpm	Vdc	rpm	Vdc
3750	1419	6.4	1506	6.8	1589	7.2	1668	7.5	1743	7.9
4065	1459	6.6	1542	7.0	1622	7.3	1699	7.7	1773	8.0
4375	1502	6.8	1581	7.1	1658	7.5	1732	7.8	1805	8.2
4690	1549	7.0	1624	7.3	1698	7.7	1769	8.0	1839	8.3
5000	1599	7.2	1670	7.6	1740	7.9	1809	8.2	1877	8.5
5315	1653	7.5	1721	7.8	1787	8.1	1853	8.4	1918	8.7
5625	1709	7.7	1773	8.0	1836	8.3	1899	8.6	1961	8.9
5940	1768	8.0	1829	8.3	1889	8.6	1949	8.8	2008	9.1
6250	1828	8.3	1886	8.6	1943	8.8	2001	9.1	2057	9.3

High Static 947-2200 rpm

Electrical data

Legend and Notes

Applicable for Electrical Data Tables on pages 53-69

LEGEND

BRKR	—	Circuit Breaker
C.O.	—	Convenience Outlet
FLA	—	Full Load Amps
IFM	—	Indoor Fan Motor
LRA	—	Locked Rotor Amps
MCA	—	Minimum Circuit Amps
P.E.	—	Power Exhaust
PWRD C.O.	—	Powered Convenience Outlet
RLA	—	Rated Load Amps
SCCR	—	Short Circuit Current Rating
UNPWR C.O.	—	Unpowered Convenience Outlet

NOTES:

1. In compliance with NEC requirements for multi-motor and combination load equipment (refer to NEC Articles 430 and 440), the overcurrent protective device for the unit shall be fuse or HACR breaker. Canadian units may be fuse or circuit breaker.
2. For 208/230 v units, where one value is show it is the same for either 208 or 230 volts.
3. **Unbalanced 3-Phase Supply Voltage**
Never operate a motor where a phase imbalance in supply voltage is greater than 2%. Use the following formula to determine the percentage of voltage imbalance.

$$\% \text{ Voltage Imbalance} = 100 \times \frac{\text{max voltage deviation from average voltage}}{\text{average voltage}}$$

Example: Supply voltage is 230-3-60

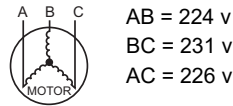

$$\text{Average Voltage} = \frac{(224 + 231 + 226)}{3} = \frac{681}{3} = 227$$

Determine maximum deviation from average voltage.

$$(AB) 227 - 224 = 3 \text{ v}$$

$$(BC) 231 - 227 = 4 \text{ v}$$

$$(AC) 227 - 226 = 1 \text{ v}$$

Maximum deviation is 4 v.

Determine percent of voltage imbalance.

$$\% \text{ Voltage Imbalance} = 100 \times \frac{4}{227} = 1.78\%$$

This amount of phase imbalance is satisfactory as it is below the maximum allowable 2%.

IMPORTANT: If the supply voltage phase imbalance is more than 2%, contact your local electric utility company immediately.

Electrical data (cont)

RHV090-150 Cooling Electrical Data

RHV UNIT SIZE	V-Ph-Hz	UNIT VOLTAGE		COMP 1		COMP 2		OFM (ea)		STD SCCR kA	IFM			POWER EXHAUST	
		RANGE		RLA	LRA	RLA	LRA	WATTS	FLA		TYPE	EFFCY AT FULL LOAD	FLA	KIT QTY	FLA
		MIN	MAX												
090	208-3-60	187	253	13.1	83	13.1	83	325	1.5	5	STD/MED HIGH	90%	6.4 7.5	1	3.8
	230-3-60	187	253	13.1	83	13.1	83	325	1.5	5	STD/MED HIGH	90%	6.4 7.5	1	3.8
	460-3-60	414	506	6.1	41	6.1	41	325	0.8	5	STD/MED HIGH	90%	3.0 3.5	1	1.8
	575-3-60	518	633	4.4	33	4.4	33	325	0.6	5	STD/MED HIGH	90%	2.5 3.0	1	3.8
102	208-3-60	187	253	13.1	83	13.1	83	325	1.5	5	STD/MED HIGH	90%	6.4 7.5	1	3.8
	230-3-60	187	253	13.1	83	13.1	83	325	1.5	5	STD/MED HIGH	90%	6.4 7.5	1	3.8
	460-3-60	414	506	6.3	55	6.2	41	325	0.8	5	STD/MED HIGH	90%	3.0 3.5	1	1.8
	575-3-60	518	633	5.8	39	4.8	33	325	0.6	5	STD/MED HIGH	90%	2.5 3.0	1	3.8
120	208-3-60	187	253	13.1	83	13.1	83	1070	7.4	5	STD/MED HIGH	90%	6.4 12.6	1	3.8
	230-3-60	187	253	13.1	83	13.1	83	1070	7.4	5	STD/MED HIGH	90%	6.4 12.6	1	3.8
	460-3-60	414	506	7.7	52	7.7	52	1070	7.4	5	STD/MED HIGH	90%	3.0 5.6	1	1.8
	575-3-60	518	633	5.8	39	5.8	39	1070	7.4	5	STD/MED HIGH	90%	2.5 4.6	1	3.8
150	208-3-60	187	253	13.1	83	13.1	83	280	1.5	5	STD/MED HIGH	90%	7.5 12.6	1	3.8
	230-3-60	187	253	13.1	83	13.1	83	280	1.5	5	STD/MED HIGH	90%	7.5 12.6	1	3.8
	460-3-60	414	506	7.7	60	7.7	60	280	0.8	5	STD/MED HIGH	90%	3.5 5.6	1	1.8
	575-3-60	518	633	5.8	41	5.8	41	280	0.6	5	STD/MED HIGH	90%	3.0 4.6	1	3.8

Electrical data (cont)

RHV090 MCA MOCP Electrical Data

RHV UNIT SIZE	NOM. V-Ph-Hz	IFM TYPE	STD SCCR kA	ELECTRIC HEATER			NO CONVENIENCE OUTLET or UNPOWERED CONVENIENCE OUTLET								
				CRHEATER ****00	NOM. (kW)	FLA	NO POWER EXHAUST				w/ POWER EXHAUST (powered from unit)				
							MCA	FUSE or HACR BRKR	DISCONNECT SIZE		MCA	FUSE or HACR BRKR	DISCONNECT SIZE		
									FLA	LRA			FLA	LRA	
RHV090	208/230-3-60	STD/ MED	5	—	—	—	39	50	41	183	43	50	45	187	
			5	411A	7.8/10.4	21.7/25.0	66/71	70/80	66/70	205/208	70/74	70/80	70/74	209/212	
			5	412A	12.0/16.0	33.4/38.5	81/87	90/90	79/85	216/222	85/91	90/100	84/90	220/226	
			5	414A	18.8/25.0	52.1/60.1	104/114	110/125	101/110	235/243	108/118	110/125	105/114	239/247	
			5	415A	24.0/32.0	66.7/77.0	123/136	125/150	118/129	250/260	127/139	150/150	122/134	254/264	
			5	416A	31.8/42.4	88.4/102.0	150/167	150/175	143/158	271/285	154/171	175/175	147/163	275/289	
		HIGH	5	—	—	—	40	50	42	185	44	50	47	189	
			5	411A	7.8/10.4	21.7/25.0	68/72	70/80	67/71	207/210	71/75	80/80	72/75	211/214	
			5	412A	12.0/16.0	33.4/38.5	82/89	90/90	81/86	218/224	86/92	90/100	85/91	222/228	
			5	414A	18.8/25.0	52.1/60.1	106/116	110/125	102/111	237/245	109/119	110/125	106/116	241/249	
			5	415A	24.0/32.0	66.7/77.0	124/137	125/150	119/131	252/262	128/140	150/150	123/135	256/266	
			5	416A	31.8/42.4	88.4/102.0	151/168	175/175	144/160	273/287	155/172	175/175	148/164	277/291	
		460-3-60	STD/ MED	5	—	—	—	19	20	19	90	21	25	21	92
				5	420A	15.0	18.0	41	45	40	108	43	45	42	110
	5			421A	25.0	30.1	56	60	54	120	58	60	56	122	
	5			422A	33.0	39.7	68	70	65	130	70	70	67	132	
	5			423A	41.7	50.2	82	90	77	140	83	90	79	142	
	HIGH		5	—	—	—	19	25	20	93	21	25	22	95	
			5	420A	15.0	18.0	42	45	41	111	44	45	43	113	
			5	421A	25.0	30.1	57	60	55	123	59	60	57	125	
			5	422A	33.0	39.7	69	70	66	133	71	80	68	135	
			5	423A	41.7	50.2	82	90	78	143	84	90	80	145	
	575-3-60	STD/ MED	5	—	—	—	14	15	14	74	18	20	19	78	
			5	425A	18.0	17.3	36	40	34	91	39	40	39	95	
			5	427A	36.0	34.6	57	60	54	109	61	70	59	113	
		HIGH	5	—	—	—	15	20	15	75	18	20	19	79	
			5	425A	18.0	17.3	36	40	35	92	40	40	39	96	
			5	427A	36.0	34.6	58	60	55	110	62	70	59	114	

Electrical data (cont)

RHV090 MCA MOCP Electrical Data (cont)

RHV UNIT SIZE	NOM. V-Ph-Hz	IFM TYPE	STD SCCR KA	ELECTRIC HEATER			w/ POWERED CONVENIENCE OUTLET								
				CRHEATER ****00	NOM. (kW)	FLA	NO POWER EXHAUST				w/ POWER EXHAUST (powered from unit)				
							MCA	FUSE or HACR BRKR	DISCONNECT SIZE		MCA	FUSE or HACR BRKR	DISCONNECT SIZE		
								FLA	LRA			FLA	LRA		
RHV090	208/230-3-60	STD/ MED	5	—	—	—	44	50	46	188	48	60	51	192	
			5	411A	7.8/10.4	21.7/25.0	71/75	80/80	71/75	210/213	75/79	80/80	76/80	214/217	
			5	412A	12.0/16.0	33.4/38.5	86/92	90/100	85/91	221/227	90/96	90/100	89/95	225/231	
			5	414A	18.8/25.0	52.1/60.1	109/119	110/125	106/116	240/248	113/123	125/125	111/120	244/252	
			5	415A	24.0/32.0	66.7/77.0	128/140	150/150	123/135	255/265	131/144	150/150	128/139	259/269	
		5	416A	31.8/42.4	88.4/102.0	155/172	175/175	148/164	276/290	158/175	175/175	152/168	280/294		
		HIGH	5	—	—	—	45	50	48	190	49	60	52	194	
			5	411A	7.8/10.4	21.7/25.0	72/76	80/80	73/76	212/215	76/80	80/80	77/81	216/219	
			5	412A	12.0/16.0	33.4/38.5	87/93	90/100	86/92	223/229	91/97	100/100	91/96	227/233	
			5	414A	18.8/25.0	52.1/60.1	110/120	110/125	108/117	242/250	114/124	125/125	112/121	246/254	
			5	415A	24.0/32.0	66.7/77.0	129/141	150/150	124/136	257/267	132/145	150/150	129/141	261/271	
		5	416A	31.8/42.4	88.4/102.0	156/173	175/175	149/165	278/292	160/177	175/200	154/169	282/296		
		460-3-60	STD/ MED	5	—	—	—	21	25	22	92	23	25	24	94
				5	420A	15.0	18.0	43	45	43	110	45	45	45	112
	5			421A	25.0	30.1	59	60	56	122	60	60	59	124	
	5			422A	33.0	39.7	71	80	68	132	72	80	70	134	
	5			423A	41.7	50.2	84	90	80	142	86	90	82	144	
	HIGH		5	—	—	—	21	25	22	95	23	25	24	97	
			5	420A	15.0	18.0	44	45	43	113	46	50	45	115	
			5	421A	25.0	30.1	59	60	57	125	61	70	59	127	
			5	422A	33.0	39.7	71	80	68	135	73	80	70	137	
			5	423A	41.7	50.2	84	90	80	145	86	90	82	147	
	575-3-60	STD/ MED	5	—	—	—	16	20	16	76	20	25	21	80	
			5	425A	18.0	17.3	37	40	36	93	41	45	41	97	
			5	427A	36.0	34.6	59	60	56	111	63	70	60	115	
		HIGH	5	—	—	—	16	20	17	77	20	25	21	81	
			5	425A	18.0	17.3	38	40	37	94	42	45	41	98	
	5	427A	36.0	34.6	60	60	57	112	63	70	61	116			

Electrical data (cont)

RHV102 MCA MOCP Electrical Data

RHV UNIT SIZE	NOM. V-Ph-Hz	IFM TYPE	STD SCCR kA	ELECTRIC HEATER			NO CONVENIENCE OUTLET or UNPOWERED CONVENIENCE OUTLET									
				CRHEATER ****00	NOM. (kW)	FLA	NO POWER EXHAUST				w/ POWER EXHAUST (powered from unit)					
							MCA	FUSE or HACR BRKR	DISCONNECT SIZE		MCA	FUSE or HACR BRKR	DISCONNECT SIZE			
									FLA	LRA			FLA	LRA		
RHV102	208/230-3-60	STD/ MED	5	—	—	—	42	50	43	198	45	50	48	202		
			5	411A	7.8/10.4	21.7/25.0	69/73	70/80	68/72	220/223	73/77	80/80	73/76	224/227		
			5	412A	12.0/16.0	33.4/38.5	83/90	90/90	82/88	231/237	87/94	90/100	86/92	235/241		
			5	414A	18.8/25.0	52.1/60.1	107/117	110/125	103/112	250/258	111/121	125/125	108/117	254/262		
			5	415A	24.0/32.0	66.7/77.0	125/138	125/150	120/132	265/275	129/142	150/150	124/136	269/279		
			5	416A	31.8/42.4	88.4/102.0	152/169	175/175	145/161	286/300	156/173	175/175	149/165	290/304		
		HIGH	5	—	—	—	43	50	45	200	47	60	49	204		
			5	411A	7.8/10.4	21.7/25.0	70/74	70/80	69/73	222/225	74/78	80/80	74/78	226/229		
			5	412A	12.0/16.0	33.4/38.5	85/91	90/100	83/89	233/239	88/95	90/100	87/93	237/243		
			5	414A	18.8/25.0	52.1/60.1	108/118	110/125	104/114	252/260	112/122	125/125	109/118	256/264		
			5	415A	24.0/32.0	66.7/77.0	126/139	150/150	121/133	267/277	130/143	150/150	126/137	271/281		
			5	416A	31.8/42.4	88.4/102.0	153/170	175/175	146/162	288/302	157/174	175/175	151/166	292/306		
			460-3-60	STD/ MED	5	—	—	—	19	25	20	104	21	25	22	106
					5	420A	15.0	18.0	42	45	40	122	43	45	42	124
	5	421A			25.0	30.1	57	60	54	134	59	60	56	136		
	5	422A			33.0	39.7	69	70	65	144	71	80	67	146		
	5	423A			41.7	50.2	82	90	77	154	84	90	79	156		
	5	—			—	—	20	25	20	107	21	25	22	109		
	HIGH	5		420A	15.0	18.0	42	45	41	125	44	45	43	127		
		5		421A	25.0	30.1	57	60	55	137	59	60	57	139		
		5		422A	33.0	39.7	69	70	66	147	71	80	68	149		
		5		423A	41.7	50.2	82	90	78	157	84	90	80	159		
		575-3-60		STD/ MED	5	—	—	—	16	20	16	80	20	25	21	84
					5	425A	18.0	17.3	38	40	36	97	42	45	41	101
					5	427A	36.0	34.6	59	60	56	115	63	70	61	119
				HIGH	5	—	—	—	17	20	17	81	21	25	21	85
	5		425A		18.0	17.3	38	40	37	98	42	45	41	102		
	5		427A		36.0	34.6	60	60	57	116	64	70	61	120		

Electrical data (cont)

RHV102 MCA MOCP Electrical Data (cont)

RHV UNIT SIZE	NOM. V-Ph-Hz	IFM TYPE	STD SCCR KA	ELECTRIC HEATER			w/ POWERED CONVENIENCE OUTLET								
				CRHEATER ****00	NOM. (kW)	FLA	NO POWER EXHAUST				w/ POWER EXHAUST (powered from unit)				
							MCA	FUSE or HACR BRKR	DISCONNECT SIZE		MCA	FUSE or HACR BRKR	DISCONNECT SIZE		
								FLA	LRA			FLA	LRA		
RHV102	208/230-3-60	STD/MED	5	—	—	—	46	60	49	203	50	60	53	207	
			5	411A	7.8/10.4	21.7/25.0	74/78	80/80	74/78	225/228	77/82	80/90	78/82	229/232	
			5	412A	12.0/16.0	33.4/38.5	88/95	90/100	87/93	236/242	92/98	100/100	92/97	240/246	
			5	414A	18.8/25.0	52.1/60.1	112/122	125/125	109/118	255/263	115/125	125/125	113/122	259/267	
			5	415A	24.0/32.0	66.7/77.0	130/143	150/150	125/137	270/280	134/147	150/150	130/142	274/284	
		5	416A	31.8/42.4	88.4/102.0	157/174	175/175	150/166	291/305	161/178	175/200	155/170	295/309		
		HIGH	5	—	—	—	48	60	50	205	51	60	54	209	
			5	411A	7.8/10.4	21.7/25.0	75/79	80/80	75/79	227/230	79/83	80/90	79/83	231/234	
			5	412A	12.0/16.0	33.4/38.5	89/96	90/100	88/94	238/244	93/100	100/100	93/99	242/248	
			5	414A	18.8/25.0	52.1/60.1	113/123	125/125	110/119	257/265	117/127	125/150	114/124	261/269	
			5	415A	24.0/32.0	66.7/77.0	131/144	150/150	127/139	272/282	135/148	150/150	131/143	276/286	
		5	416A	31.8/42.4	88.4/102.0	158/175	175/175	152/167	293/307	162/179	175/200	156/172	297/311		
		460-3-60	STD/MED	5	—	—	—	21	25	22	106	23	25	24	108
				5	420A	15.0	18.0	44	45	43	124	46	50	45	126
	5			421A	25.0	30.1	59	60	57	136	61	70	59	138	
	5			422A	33.0	39.7	71	80	68	146	73	80	70	148	
	5			423A	41.7	50.2	84	90	80	156	86	90	82	158	
	HIGH		5	—	—	—	22	25	23	109	24	25	25	111	
			5	420A	15.0	18.0	44	45	43	127	46	50	46	129	
			5	421A	25.0	30.1	59	60	57	139	61	70	59	141	
			5	422A	33.0	39.7	71	80	68	149	73	80	70	151	
			5	423A	41.7	50.2	85	90	81	159	86	90	83	161	
	575-3-60	STD/MED	5	—	—	—	18	20	18	82	22	25	23	86	
			5	425A	18.0	17.3	40	40	38	99	43	45	43	103	
			5	427A	36.0	34.6	61	70	58	117	65	70	63	121	
		HIGH	5	—	—	—	18	20	19	83	22	25	23	87	
			5	425A	18.0	17.3	40	40	39	100	44	45	43	104	
			5	427A	36.0	34.6	62	70	59	118	65	70	63	122	

Electrical data (cont)

RHV120 MCA MOCOP Electrical Data

RHV UNIT SIZE	NOM. V-Ph-Hz	IFM TYPE	STD SCCR kA	ELECTRIC HEATER			NO CONVENIENCE OUTLET or UNPOWERED CONVENIENCE OUTLET								
				CRHEATER ****00	NOM. (kW)	FLA	NO POWER EXHAUST				w/ POWER EXHAUST (powered from unit)				
							MCA	FUSE or HACR BRKR	DISCONNECT SIZE		MCA	FUSE or HACR BRKR	DISCONNECT SIZE		
									FLA	LRA			FLA	LRA	
RHV120	208/230-3-60	STD/ MED	5	—	—	—	49	60	52	236	53	60	56	240	
			5	411A	7.8/10.4	21.7/25.0	76/81	80/90	77/81	258/261	80/84	80/90	81/85	262/265	
			5	412A	12.0/16.0	33.4/38.5	91/97	100/100	90/96	269/275	95/101	100/110	95/100	273/279	
			5	415A	24.0/32.0	66.7/77.0	133/146	150/150	128/140	303/313	137/149	150/150	133/145	307/317	
			5	416A	31.8/42.4	88.4/102.0	160/177	175/200	153/169	324/338	164/181	175/200	158/173	328/342	
		5	417A	37.6/50.0	104.2/120.3	180/170	200/175	172/190	340/356	183/173	200/200	176/194	344/360		
		HIGH	5	—	—	—	56	60	59	245	59	70	63	249	
			5	411A	7.8/10.4	21.7/25.0	83/87	90/90	84/88	267/270	86/91	90/100	88/92	271/274	
			5	412A	12.0/16.0	33.4/38.5	97/104	100/110	97/103	278/284	101/107	110/110	102/108	282/288	
			5	415A	24.0/32.0	66.7/77.0	139/152	150/175	136/147	312/322	143/156	150/175	140/152	316/326	
			5	416A	31.8/42.4	88.4/102.0	166/183	175/200	161/176	333/347	170/187	175/200	165/181	337/351	
		5	417A	37.6/50.0	104.2/120.3	186/176	200/200	179/197	349/365	190/180	200/200	183/202	353/369		
		460-3-60	STD/ MED	5	—	—	—	28	30	30	115	30	35	32	117
				5	420A	15.0	18.0	51	60	50	133	52	60	52	135
				5	422A	33.0	39.7	78	80	75	155	80	80	77	157
	5			423A	41.7	50.2	91	100	87	165	93	100	89	167	
	5			424A	50.0	60.1	88	90	99	175	90	100	101	177	
	HIGH		5	—	—	—	31	35	33	119	33	35	35	121	
			5	420A	15.0	18.0	53	60	53	137	55	60	55	139	
			5	422A	33.0	39.7	80	80	78	159	82	90	80	161	
			5	423A	41.7	50.2	94	100	90	169	95	100	92	171	
			5	424A	50.0	60.1	91	100	102	179	93	100	104	181	
	575-3-60	STD/ MED	5	—	—	—	24	30	25	89	28	30	29	93	
			5	425A	18.0	17.3	45	45	45	106	49	50	49	110	
			5	427A	36.0	34.6	67	70	65	124	71	80	69	128	
			5	428A	50.0	48.1	72	80	80	137	76	80	84	141	
		HIGH	5	—	—	—	26	30	27	91	30	35	32	95	
			5	425A	18.0	17.3	48	50	47	108	51	60	51	112	
			5	427A	36.0	34.6	69	70	67	126	73	80	71	130	
			5	428A	50.0	48.1	74	80	82	139	78	80	87	143	

Electrical data (cont)

RHV120 MCA MOCP Electrical Data (cont)

RHV UNIT SIZE	NOM. V-Ph-Hz	IFM TYPE	STD SCCR kA	ELECTRIC HEATER			w/ POWERED CONVENIENCE OUTLET								
				CRHEATER ****00	NOM. (kW)	FLA	NO POWER EXHAUST				w/ POWER EXHAUST (powered from unit)				
							MCA	FUSE or HACR BRKR	DISCONNECT SIZE		MCA	FUSE or HACR BRKR	DISCONNECT SIZE		
									FLA	LRA			FLA	LRA	
RHV120	208/230-3-60	STD/ MED	5	—	—	—	54	60	57	241	58	70	62	245	
			5	411A	7.8/10.4	21.7/25.0	81/85	90/90	82/86	263/266	85/89	90/90	87/90	267/270	
			5	412A	12.0/16.0	33.4/38.5	96/102	100/110	96/102	274/280	100/106	100/110	100/106	278/284	
			5	415A	24.0/32.0	66.7/77.0	138/150	150/150	134/146	308/318	141/154	150/175	138/150	312/322	
			5	416A	31.8/42.4	88.4/102.0	165/182	175/200	159/175	329/343	168/185	175/200	163/179	333/347	
		5	417A	37.6/50.0	104.2/120.3	184/174	200/200	177/196	345/361	188/178	200/200	181/200	349/365		
		HIGH	5	—	—	—	60	70	64	250	64	70	69	254	
			5	411A	7.8/10.4	21.7/25.0	87/92	90/100	89/93	272/275	91/95	100/100	94/98	276/279	
			5	412A	12.0/16.0	33.4/38.5	102/108	110/110	103/109	283/289	106/112	110/125	107/113	287/293	
			5	415A	24.0/32.0	66.7/77.0	144/157	150/175	141/153	317/327	148/160	150/175	145/157	321/331	
			5	416A	31.8/42.4	88.4/102.0	171/188	175/200	166/182	338/352	175/192	175/200	170/186	342/356	
		5	417A	37.6/50.0	104.2/120.3	191/181	200/200	184/203	354/370	194/184	200/200	189/207	358/374		
		460-3-60	STD/ MED	5	—	—	—	30	35	32	117	32	35	34	119
				5	420A	15.0	18.0	53	60	53	135	55	60	55	137
	5			422A	33.0	39.7	80	80	78	157	82	90	80	159	
	5			423A	41.7	50.2	93	100	90	167	95	100	92	169	
	5			424A	50.0	60.1	90	100	101	177	92	100	103	179	
	HIGH		5	—	—	—	33	40	35	121	35	40	37	123	
			5	420A	15.0	18.0	55	60	56	139	57	60	58	141	
			5	422A	33.0	39.7	83	90	81	161	84	90	83	163	
			5	423A	41.7	50.2	96	100	93	171	98	100	95	173	
			5	424A	50.0	60.1	93	100	104	181	95	100	106	183	
	575-3-60		STD/ MED	5	—	—	—	26	30	27	91	29	35	31	95
				5	425A	18.0	17.3	47	50	47	108	51	60	51	112
				5	427A	36.0	34.6	69	70	66	126	73	80	71	130
				5	428A	50.0	48.1	74	80	82	139	77	80	86	143
		HIGH	5	—	—	—	28	30	29	93	31	35	33	97	
			5	425A	18.0	17.3	49	50	49	110	53	60	53	114	
5			427A	36.0	34.6	71	80	69	128	75	80	73	132		
5			428A	50.0	48.1	76	80	84	141	80	90	89	145		

Electrical data (cont)

RHV150 MCA MOCP Electrical Data

RHV UNIT SIZE	NOM. V-Ph-Hz	IFM TYPE	STD SCCR kA	ELECTRIC HEATER			NO CONVENIENCE OUTLET or UNPOWERED CONVENIENCE OUTLET								
				CRHEATER ****00	NOM. (kW)	FLA	NO POWER EXHAUST				w/ POWER EXHAUST (powered from unit)				
							MCA	FUSE or HACR BRKR	DISCONNECT SIZE		MCA	FUSE or HACR BRKR	DISCONNECT SIZE		
									FLA	LRA			FLA	LRA	
RHV150	208/230-3-60	STD/ MED	5	—	—	—	48	60	50	209	51	60	54	213	
			5	411A	7.8/10.4	21.7/25.0	75/79	80/80	75/78	231/234	78/83	80/90	79/83	235/238	
			5	412A	12.0/16.0	33.4/38.5	89/96	90/100	88/94	242/248	93/99	100/100	92/98	246/252	
			5	415A	24.0/32.0	66.7/77.0	131/144	150/150	126/138	276/286	135/148	150/150	131/143	280/290	
			5	416A	31.8/42.4	88.4/102.0	158/175	175/175	151/167	297/311	162/179	175/200	156/171	301/315	
		5	417A	37.6/50.0	104.2/120.3	178/168	200/175	170/188	313/329	182/172	200/200	174/192	317/333		
		HIGH	5	—	—	—	53	60	56	216	56	60	60	220	
			5	411A	7.8/10.4	21.7/25.0	80/84	80/90	81/84	238/241	84/88	90/90	85/89	242/245	
			5	412A	12.0/16.0	33.4/38.5	94/101	100/110	94/100	249/255	98/105	100/110	98/104	253/259	
			5	415A	24.0/32.0	66.7/77.0	136/149	150/150	132/144	283/293	140/153	150/175	137/148	287/297	
			5	416A	31.8/42.4	88.4/102.0	163/180	175/200	157/173	304/318	167/184	175/200	162/177	308/322	
		5	417A	37.6/50.0	104.2/120.3	183/173	200/200	175/194	320/336	187/177	200/200	180/198	324/340		
		460-3-60	STD/ MED	5	—	—	—	24	30	24	133	25	30	27	135
				5	420A	15.0	18.0	46	50	45	151	48	50	47	153
				5	422A	33.0	39.7	73	80	70	173	75	80	72	175
	5			423A	41.7	50.2	86	90	82	183	88	90	84	185	
	5			424A	50.0	60.1	84	90	94	193	86	90	96	195	
	HIGH		5	—	—	—	26	30	27	134	28	30	29	136	
			5	420A	15.0	18.0	48	50	48	152	50	50	50	154	
			5	422A	33.0	39.7	75	80	73	174	77	80	75	176	
			5	423A	41.7	50.2	89	90	85	184	90	90	87	186	
			5	424A	50.0	60.1	86	90	96	194	88	90	98	196	
	575-3-60	STD/ MED	5	—	—	—	18	20	19	93	22	25	23	97	
			5	425A	18.0	17.3	40	40	39	110	44	45	43	114	
			5	427A	36.0	34.6	62	70	59	128	65	70	63	132	
			5	428A	50.0	48.1	66	70	74	141	70	80	79	145	
		HIGH	5	—	—	—	20	25	21	94	24	25	25	98	
			5	425A	18.0	17.3	42	45	41	111	45	45	45	115	
			5	427A	36.0	34.6	63	70	60	129	67	70	65	133	
			5	428A	50.0	48.1	68	70	76	142	72	80	80	146	

Electrical data (cont)

RHV150 MCA MOCP Electrical Data (cont)

RHV UNIT SIZE	NOM. V-Ph-Hz	IFM TYPE	STD SCCR kA	ELECTRIC HEATER			w/ POWERED CONVENIENCE OUTLET								
				CRHEATER ****00	NOM. (kW)	FLA	NO POWER EXHAUST				w/ POWER EXHAUST (powered from unit)				
							MCA	FUSE or HACR BRKR	DISCONNECT SIZE		MCA	FUSE or HACR BRKR	DISCONNECT SIZE		
									FLA	LRA			FLA	LRA	
RHV150	208/230-3-60	STD/ MED	5	—	—	—	52	60	55	214	56	60	60	218	
			5	411A	7.8/10.4	21.7/25.0	79/84	80/90	80/84	236/239	83/87	90/90	85/88	240/243	
			5	412A	12.0/16.0	33.4/38.5	94/100	100/110	94/99	247/253	98/104	100/110	98/104	251/257	
			5	415A	24.0/32.0	66.7/77.0	136/149	150/150	132/144	281/291	140/152	150/175	136/148	285/295	
			5	416A	31.8/42.4	88.4/102.0	163/180	175/200	157/173	302/316	167/184	175/200	161/177	306/320	
		5	417A	37.6/50.0	104.2/120.3	183/173	200/200	175/194	318/334	186/176	200/200	179/198	322/338		
		HIGH	5	—	—	—	57	70	61	221	61	70	65	225	
			5	411A	7.8/10.4	21.7/25.0	85/89	90/90	86/90	243/246	88/93	90/100	90/94	247/250	
			5	412A	12.0/16.0	33.4/38.5	99/106	100/110	99/105	254/260	103/109	110/110	104/110	258/264	
			5	415A	24.0/32.0	66.7/77.0	141/154	150/175	138/150	288/298	145/158	150/175	142/154	292/302	
			5	416A	31.8/42.4	88.4/102.0	168/185	175/200	163/178	309/323	172/189	175/200	167/183	313/327	
		5	417A	37.6/50.0	104.2/120.3	188/178	200/200	181/199	325/341	192/182	200/200	185/204	329/345		
		460-3-60	STD/ MED	5	—	—	—	26	30	27	135	28	30	29	137
				5	420A	15.0	18.0	48	50	48	153	50	50	50	155
	5			422A	33.0	39.7	76	80	73	175	77	80	75	177	
	5			423A	41.7	50.2	89	90	85	185	90	90	87	187	
	5			424A	50.0	60.1	86	90	96	195	88	90	98	197	
	HIGH		5	—	—	—	28	30	29	136	30	35	32	138	
			5	420A	15.0	18.0	50	60	50	154	52	60	52	156	
			5	422A	33.0	39.7	78	80	75	176	79	80	77	178	
			5	423A	41.7	50.2	91	100	87	186	93	100	89	188	
			5	424A	50.0	60.1	88	90	99	196	90	100	101	198	
	575-3-60	STD/ MED	5	—	—	—	20	25	21	95	24	25	25	99	
			5	425A	18.0	17.3	42	45	41	112	45	45	45	116	
			5	427A	36.0	34.6	63	70	61	130	67	70	65	134	
			5	428A	50.0	48.1	68	70	76	143	72	80	81	147	
		HIGH	5	—	—	—	22	25	23	96	25	30	27	100	
			5	425A	18.0	17.3	43	45	43	113	47	50	47	117	
5			427A	36.0	34.6	65	70	62	131	69	70	67	135		
5			428A	50.0	48.1	70	80	78	144	74	80	82	148		

Electrical data (cont)

RHV090 Electric Heat Data — Without Non-Fused Disconnect

RHV UNIT SIZE	NOM. V-Ph-Hz	IFM TYPE	ELECTRIC HEATER PART NUMBER	NOM. (kW)	STD SCCR kA	APPLICATION (kW)	APPLICATION OUTPUT (MBH)	SINGLE POINT OR JUNCTION KIT PART NUMBER CRSINGLEXXXXA00			
								NO C.O. OR UNPOWERED C.O.		w/PWRD C.O.	
								NO P.E.	w/P.E. (pwrd fr/unit)	NO P.E.	w/P.E. (pwrd fr/unit)
RHV090	208/230-3-60	STD/ MED	CRHEATER411A00	10.4	5	7.8/9.6	26.7/32.6	049	049	049	049
			CRHEATER412A00	16	5	12.0/14.7	41.0/50.1	049	049	049	049
			CRHEATER414A00	25	5	18.8/23.0	64.1/78.3	051	051	051	051
			CRHEATER415A00	32	5	24.0/29.4	82.0/100.3	051	051	051	051
		CRHEATER416A00	42.4	5	31.8/38.9	108.7/132.9	053	053	053	053	
		HIGH	CRHEATER411A00	10.4	5	7.8/9.6	26.7/32.6	049	049	049	049
			CRHEATER412A00	16	5	12.0/14.7	41.0/50.1	049	049	049	049
			CRHEATER414A00	25	5	18.8/23.0	64.1/78.3	051	051	051	051
	CRHEATER415A00		32	5	24.0/29.4	82.0/100.3	051	051	051	051	
	CRHEATER416A00	42.4	5	31.8/38.9	108.7/132.9	053	053	053	053		
	460-3-60	STD/ MED	CRHEATER420A00	15	5	13.8	47.0	047	047	047	047
			CRHEATER421A00	25	5	23.0	78.3	047	047	047	047
			CRHEATER422A00	33	5	30.3	103.4	052	052	052	052
			CRHEATER423A00	41.7	5	38.3	130.7	052	052	052	052
		HIGH	CRHEATER420A00	15	5	13.8	47.0	047	047	047	047
			CRHEATER421A00	25	5	23.0	78.3	047	047	047	052
			CRHEATER422A00	33	5	30.3	103.4	052	052	052	052
			CRHEATER423A00	41.7	5	38.3	130.7	052	052	052	052
	575-3-60	STD/ MED	CRHEATER425A00	18	5	16.5	56.4	047	047	047	047
			CRHEATER427A00	36	5	33.1	112.8	047	052	047	052
		HIGH	CRHEATER425A00	18	5	16.5	56.4	047	047	047	047
			CRHEATER427A00	36	5	33.1	112.8	047	052	047	052

Electrical data (cont)

RHV090 Electric Heat Data — With Non-Fused Disconnect

RHV UNIT SIZE	NOM. V-Ph-Hz	IFM TYPE	ELECTRIC HEATER PART NUMBER	NOM. (kW)	STD SCCR kA	APPLICATION (kW)	APPLICATION OUTPUT (MBH)	SINGLE POINT OR JUNCTION KIT PART NUMBER CRSINGLEXXXXA00			
								NO C.O. OR UNPOWERED C.O.		w/PWRD C.O.	
								NO P.E.	w/P.E. (pwrd fr/unit)	NO P.E.	w/P.E. (pwrd fr/unit)
RHV090	208/230-3-60	STD/ MED	CRHEATER411A00	10.4	5.0	7.8/9.6	26.7/32.6	049	049	049	049
			CRHEATER412A00	16.0	5.0	12.0/14.7	41.0/50.1	049	049	049	049
			CRHEATER414A00	25.0	5.0	18.8/23.0	64.1/78.3	051	051	051	051
			CRHEATER415A00	32.0	5.0	24.0/29.4	82.0/100.3	051	051	051	051
		CRHEATER416A00	42.4	5.0	31.8/38.9	108.7/132.9	053	053	053	053	
		HIGH	CRHEATER411A00	10.4	5.0	7.8/9.6	26.7/32.6	049	049	049	049
			CRHEATER412A00	16.0	5.0	12.0/14.7	41.0/50.1	049	049	049	049
			CRHEATER414A00	25.0	5.0	18.8/23.0	64.1/78.3	051	051	051	051
	CRHEATER415A00		32.0	5.0	24.0/29.4	82.0/100.3	051	051	051	051	
	CRHEATER416A00	42.4	5.0	31.8/38.9	108.7/132.9	053	053	053	053		
	460-3-60	STD/ MED	CRHEATER420A00	15.0	5.0	13.8	47.0	047	047	047	047
			CRHEATER421A00	25.0	5.0	23.0	78.3	047	047	047	047
			CRHEATER422A00	33.0	5.0	30.3	103.4	052	052	052	052
			CRHEATER423A00	41.7	5.0	38.3	130.7	052	052	052	052
		HIGH	CRHEATER420A00	15.0	5.0	13.8	47.0	047	047	047	047
			CRHEATER421A00	25.0	5.0	23.0	78.3	047	047	047	052
			CRHEATER422A00	33.0	5.0	30.3	103.4	052	052	052	052
			CRHEATER423A00	41.7	5.0	38.3	130.7	052	052	052	052
	575-3-60	STD/ MED	CRHEATER425A00	18.0	5.0	16.5	56.4	047	047	047	047
			CRHEATER427A00	36.0	5.0	33.1	112.8	047	052	047	052
		HIGH	CRHEATER425A00	18.0	5.0	16.5	56.4	047	047	047	047
			CRHEATER427A00	36.0	5.0	33.1	112.8	047	052	047	052

Electrical data (cont)

RHV102 Electric Heat Data — Without Non-Fused Disconnect

RHV UNIT SIZE	NOM. V-Ph-Hz	IFM TYPE	ELECTRIC HEATER PART NUMBER	NOM. (kW)	STD SCCR kA	APPLICATION (kW)	APPLICATION OUTPUT (MBH)	SINGLE POINT OR JUNCTION KIT PART NUMBER CRSINGLEXXXXA00			
								NO C.O. OR UNPOWERED C.O.		w/PWRD C.O.	
								NO P.E.	w/P.E. (pwrd fr/unit)	NO P.E.	w/P.E. (pwrd fr/unit)
RHV102	208/230-3-60	STD/ MED	CRHEATER411A00	10.4	5	7.8/9.6	26.7/32.6	049	049	049	049
			CRHEATER412A00	16	5	12.0/14.7	41.0/50.1	049	049	049	049
			CRHEATER414A00	25	5	18.8/23.0	64.1/78.3	051	051	051	051
			CRHEATER415A00	32	5	24.0/29.4	82.0/100.3	051	051	051	051
		CRHEATER416A00	42.4	5	31.8/38.9	108.7/132.9	053	053	053	053	
		HIGH	CRHEATER411A00	10.4	5	7.8/9.6	26.7/32.6	049	049	049	049
			CRHEATER412A00	16	5	12.0/14.7	41.0/50.1	049	049	049	049
			CRHEATER414A00	25	5	18.8/23.0	64.1/78.3	051	051	051	051
	CRHEATER415A00		32	5	24.0/29.4	82.0/100.3	051	051	051	051	
	CRHEATER416A00	42.4	5	31.8/38.9	108.7/132.9	053	053	053	053		
	460-3-60	STD/ MED	CRHEATER420A00	15	5	13.8	47.0	047	047	047	047
			CRHEATER421A00	25	5	23.0	78.3	047	047	047	052
			CRHEATER422A00	33	5	30.3	103.4	052	052	052	052
			CRHEATER423A00	41.7	5	38.3	130.7	052	052	052	052
		HIGH	CRHEATER420A00	15	5	13.8	47.0	047	047	047	047
			CRHEATER421A00	25	5	23.0	78.3	047	047	047	052
			CRHEATER422A00	33	5	30.3	103.4	052	052	052	052
			CRHEATER423A00	41.7	5	38.3	130.7	052	052	052	052
	575-3-60	STD/ MED	CRHEATER425A00	18	5	16.5	56.4	047	047	047	047
			CRHEATER427A00	36	5	33.1	112.8	047	052	052	052
		HIGH	CRHEATER425A00	18	5	16.5	56.4	047	047	047	047
			CRHEATER427A00	36	5	33.1	112.8	047	052	052	052

Electrical data (cont)

RHV102 Electric Heat Data — With Non-Fused Disconnect

RHV UNIT SIZE	NOM. V-Ph-Hz	IFM TYPE	ELECTRIC HEATER PART NUMBER	NOM. (kW)	STD SCCR kA	APPLICATION (kW)	APPLICATION OUTPUT (MBH)	SINGLE POINT OR JUNCTION KIT PART NUMBER CRSINGLEXXXXA00				
								NO C.O. OR UNPOWERED C.O.		w/PWRD C.O.		
								NO P.E.	w/P.E. (pwrd fr/unit)	NO P.E.	w/P.E. (pwrd fr/unit)	
RHV102	208/230-3-60	STD/ MED	CRHEATER411A00	10.4	5.0	7.8/9.6	26.7/32.6	049	049	049	049	
			CRHEATER412A00	16.0	5.0	12.0/14.7	41.0/50.1	049	049	049	049	
			CRHEATER414A00	25.0	5.0	18.8/23.0	64.1/78.3	051	051	051	051	
			CRHEATER415A00	32.0	5.0	24.0/29.4	82.0/100.3	051	051	051	051	
		CRHEATER416A00	42.4	5.0	31.8/38.9	108.7/132.9	053	053	053	053		
		HIGH	CRHEATER411A00	10.4	5.0	7.8/9.6	26.7/32.6	049	049	049	049	
			CRHEATER412A00	16.0	5.0	12.0/14.7	41.0/50.1	049	049	049	049	
			CRHEATER414A00	25.0	5.0	18.8/23.0	64.1/78.3	051	051	051	051	
	CRHEATER415A00		32.0	5.0	24.0/29.4	82.0/100.3	051	051	051	051		
	460-3-60	STD/ MED	CRHEATER416A00	42.4	5.0	31.8/38.9	108.7/132.9	053	053	053	053	
			CRHEATER420A00	15.0	5.0	13.8	47.0	047	047	047	047	
			CRHEATER421A00	25.0	5.0	23.0	78.3	047	047	047	052	
			CRHEATER422A00	33.0	5.0	30.3	103.4	052	052	052	052	
		HIGH	CRHEATER423A00	41.7	5.0	38.3	130.7	052	052	052	052	
			CRHEATER420A00	15.0	5.0	13.8	47.0	047	047	047	047	
			CRHEATER421A00	25.0	5.0	23.0	78.3	047	047	047	052	
			CRHEATER422A00	33.0	5.0	30.3	103.4	052	052	052	052	
	575-3-60	STD/ MED	CRHEATER423A00	41.7	5.0	38.3	130.7	052	052	052	052	
			CRHEATER425A00	18.0	5.0	16.5	56.4	047	047	047	047	
		HIGH	CRHEATER427A00	36.0	5.0	33.1	112.8	047	052	052	052	
			CRHEATER425A00	18.0	5.0	16.5	56.4	047	047	047	047	
				CRHEATER427A00	36.0	5.0	33.1	112.8	047	052	052	052

Electrical data (cont)

RHV120 Electric Heat Data — Without Non-Fused Disconnect

RHV UNIT SIZE	NOM. V-Ph-Hz	IFM TYPE	ELECTRIC HEATER PART NUMBER	NOM. (kW)	STD SCCR kA	APPLICATION (kW)	APPLICATION OUTPUT (MBH)	SINGLE POINT OR JUNCTION KIT PART NUMBER CRSINGLEXXXXA00				
								NO C.O. OR UNPOWERED C.O.		w/PWRD C.O.		
								NO P.E.	w/P.E. (pwrd fr/unit)	NO P.E.	w/P.E. (pwrd fr/unit)	
RHV120	208/230-3-60	STD/ MED	CRHEATER411A00	10.4	5	7.8/9.6	26.7/32.6	049	049	049	051	
			CRHEATER412A00	16	5	12.0/14.7	41.0/50.1	049	049	049	051	
			CRHEATER415A00	32	5	24.0/29.4	82.0/100.3	051	051	051	053	
			CRHEATER416A00	42.4	5	31.8/38.9	108.7/132.9	053	053	053	054	
		CRHEATER417A00	50	5	37.6/45.9	128.1/156.7	053	053	053	054		
		HIGH	CRHEATER411A00	10.4	5	7.8/9.6	26.7/32.6	049	051	051	051	
			CRHEATER412A00	16	5	12.0/14.7	41.0/50.1	049	051	051	051	
			CRHEATER415A00	32	5	24.0/29.4	82.0/100.3	051	053	053	053	
			CRHEATER416A00	42.4	5	31.8/38.9	108.7/132.9	053	054	054	054	
		CRHEATER417A00	50	5	37.6/45.9	128.1/156.7	053	054	054	054		
		460-3-60	STD/ MED	CRHEATER420A00	15	5	13.8	47.0	047	047	047	047
				CRHEATER422A00	33	5	30.3	103.4	052	052	052	052
	CRHEATER423A00			41.7	5	38.3	130.7	052	052	052	052	
	CRHEATER424A00			50	5	45.9	156.7	052	052	052	052	
	HIGH		CRHEATER420A00	15	5	13.8	47.0	047	047	047	047	
			CRHEATER422A00	33	5	30.3	103.4	052	052	052	052	
			CRHEATER423A00	41.7	5	38.3	130.7	052	052	052	052	
			CRHEATER424A00	50	5	45.9	156.7	052	052	052	052	
	575-3-60		STD/ MED	CRHEATER425A00	18	5	16.5	56.4	047	047	047	047
				CRHEATER427A00	36	5	33.1	112.8	052	052	052	052
			HIGH	CRHEATER428A00	50	5	45.9	156.7	052	052	052	052
				CRHEATER425A00	18	5	16.5	56.4	047	047	047	047
	CRHEATER427A00	36	5	33.1	112.8	052	052	052	052			
	CRHEATER428A00	50	5	45.9	156.7	052	052	052	052			

Electrical data (cont)

RHV120 Electric Heat Data — With Non-Fused Disconnect

RHV UNIT SIZE	NOM. V-Ph-Hz	IFM TYPE	ELECTRIC HEATER PART NUMBER	NOM. (kW)	STD SCCR kA	APPLICATION (kW)	APPLICATION OUTPUT (MBH)	SINGLE POINT OR JUNCTION KIT PART NUMBER CRSINGLEXXXXA00			
								NO C.O. OR UNPOWERED C.O.		w/PWRD C.O.	
								NO P.E.	w/P.E. (pwrd fr/unit)	NO P.E.	w/P.E. (pwrd fr/unit)
RHV120	208/230-3-60	STD/ MED	CRHEATER411A00	10.4	5.0	7.8/9.6	26.7/32.6	049	049	049	051
			CRHEATER412A00	16.0	5.0	12.0/14.7	41.0/50.1	049	049	049	051
			CRHEATER415A00	32.0	5.0	24.0/29.4	82.0/100.3	051	051	051	053
			CRHEATER416A00	42.4	5.0	31.8/38.9	108.7/132.9	053	053	053	054
			CRHEATER417A00	50.0	5.0	37.6/45.9	128.1/156.7	053	053	053	054
		HIGH	CRHEATER411A00	10.4	5.0	7.8/9.6	26.7/32.6	049	051	051	051
			CRHEATER412A00	16.0	5.0	12.0/14.7	41.0/50.1	049	051	051	051
			CRHEATER415A00	32.0	5.0	24.0/29.4	82.0/100.3	051	053	053	053
			CRHEATER416A00	42.4	5.0	31.8/38.9	108.7/132.9	053	054	054	054
			CRHEATER417A00	50.0	5.0	37.6/45.9	128.1/156.7	053	054	054	054
	460-3-60	STD/ MED	CRHEATER420A00	15.0	5.0	13.8	47.0	047	047	047	047
			CRHEATER422A00	33.0	5.0	30.3	103.4	052	052	052	052
			CRHEATER423A00	41.7	5.0	38.3	130.7	052	052	052	052
			CRHEATER424A00	50.0	5.0	45.9	156.7	052	052	052	052
			CRHEATER420A00	15.0	5.0	13.8	47.0	047	047	047	047
		HIGH	CRHEATER422A00	33.0	5.0	30.3	103.4	052	052	052	052
			CRHEATER423A00	41.7	5.0	38.3	130.7	052	052	052	052
			CRHEATER424A00	50.0	5.0	45.9	156.7	052	052	052	052
			CRHEATER425A00	18.0	5.0	16.5	56.4	047	047	047	047
			CRHEATER427A00	36.0	5.0	33.1	112.8	052	052	052	052
	575-3-60	STD/ MED	CRHEATER428A00	50.0	5.0	45.9	156.7	052	052	052	052
			CRHEATER425A00	18.0	5.0	16.5	56.4	047	047	047	047
			CRHEATER427A00	36.0	5.0	33.1	112.8	052	052	052	052
		HIGH	CRHEATER425A00	18.0	5.0	16.5	56.4	047	047	047	047
CRHEATER427A00			36.0	5.0	33.1	112.8	052	052	052	052	
			CRHEATER428A00	50.0	5.0	45.9	156.7	052	052	052	052

Electrical data (cont)

RHV150 Electric Heat Data — Without Non-Fused Disconnect

RHV UNIT SIZE	NOM. V-Ph-Hz	IFM TYPE	ELECTRIC HEATER PART NUMBER	NOM. (kW)	STD SCCR kA	APPLICATION (kW)	APPLICATION OUTPUT (MBH)	SINGLE POINT OR JUNCTION KIT PART NUMBER CRSINGLEXXXXA00			
								NO C.O. OR UNPOWERED C.O.		w/PWRD C.O.	
								NO P.E.	w/P.E. (pwrd fr/unit)	NO P.E.	w/P.E. (pwrd fr/unit)
RHV150	208/230-3-60	STD/ MED	CRHEATER411A00	10.4	5	7.8/9.6	26.7/32.6	049	049	049	049
			CRHEATER412A00	16	5	12.0/14.7	41.0/50.1	049	049	049	049
			CRHEATER415A00	32	5	24.0/29.4	82.0/100.3	051	051	051	051
			CRHEATER416A00	42.4	5	31.8/38.9	108.7/132.9	053	053	053	053
		CRHEATER417A00	50	5	37.6/45.9	128.1/156.7	053	053	053	053	
		HIGH	CRHEATER411A00	10.4	5	7.8/9.6	26.7/32.6	049	049	051	051
			CRHEATER412A00	16	5	12.0/14.7	41.0/50.1	049	049	051	051
			CRHEATER415A00	32	5	24.0/29.4	82.0/100.3	051	051	053	053
	CRHEATER416A00		42.4	5	31.8/38.9	108.7/132.9	053	053	054	054	
	CRHEATER417A00	50	5	37.6/45.9	128.1/156.7	053	053	054	054		
	460-3-60	STD/ MED	CRHEATER420A00	15	5	13.8	47.0	047	047	047	047
			CRHEATER422A00	33	5	30.3	103.4	052	052	052	052
			CRHEATER423A00	41.7	5	38.3	130.7	052	052	052	052
			CRHEATER424A00	50	5	45.9	156.7	052	052	052	052
		HIGH	CRHEATER420A00	15	5	13.8	47.0	047	047	047	047
			CRHEATER422A00	33	5	30.3	103.4	052	052	052	052
			CRHEATER423A00	41.7	5	38.3	130.7	052	052	052	052
			CRHEATER424A00	50	5	45.9	156.7	052	052	052	052
	575-3-60	STD/ MED	CRHEATER425A00	18	5	16.5	56.4	047	047	047	047
			CRHEATER427A00	36	5	33.1	112.8	052	052	052	052
			CRHEATER428A00	50	5	45.9	156.7	052	052	052	052
			CRHEATER425A00	18	5	16.5	56.4	047	047	047	047
		HIGH	CRHEATER427A00	36	5	33.1	112.8	052	052	052	052
			CRHEATER428A00	50	5	45.9	156.7	052	052	052	052
CRHEATER425A00			18	5	16.5	56.4	047	047	047	047	
CRHEATER427A00			36	5	33.1	112.8	052	052	052	052	
CRHEATER428A00	50	5	45.9	156.7	052	052	052	052			

Electrical data (cont)

RHV150 Electric Heat Data — With Non-Fused Disconnect

RHV UNIT SIZE	NOM. V-Ph-Hz	IFM TYPE	ELECTRIC HEATER PART NUMBER	NOM. (kW)	STD SCCR kA	APPLICATION (kW)	APPLICATION OUTPUT (MBH)	SINGLE POINT OR JUNCTION KIT PART NUMBER CRSINGLEXXXXA00				
								NO C.O. OR UNPOWERED C.O.		w/PWRD C.O.		
								NO P.E.	w/P.E. (pwrd fr/unit)	NO P.E.	w/P.E. (pwrd fr/unit)	
RHV150	208/230-3-60	STD/ MED	CRHEATER411A00	10.4	5.0	7.8/9.6	26.7/32.6	049	049	049	049	
			CRHEATER412A00	16.0	5.0	12.0/14.7	41.0/50.1	049	049	049	049	
			CRHEATER415A00	32.0	5.0	24.0/29.4	82.0/100.3	051	051	051	051	
			CRHEATER416A00	42.4	5.0	31.8/38.9	108.7/132.9	053	053	053	053	
			CRHEATER417A00	50.0	5.0	37.6/45.9	128.1/156.7	053	053	053	053	
		HIGH	CRHEATER411A00	10.4	5.0	7.8/9.6	26.7/32.6	049	049	051	051	
			CRHEATER412A00	16.0	5.0	12.0/14.7	41.0/50.1	049	049	051	051	
			CRHEATER415A00	32.0	5.0	24.0/29.4	82.0/100.3	051	051	053	053	
			CRHEATER416A00	42.4	5.0	31.8/38.9	108.7/132.9	053	053	054	054	
			CRHEATER417A00	50.0	5.0	37.6/45.9	128.1/156.7	053	053	054	054	
			STD/ MED	CRHEATER420A00	15.0	5.0	13.8	47.0	047	047	047	047
				CRHEATER422A00	33.0	5.0	30.3	103.4	052	052	052	052
	CRHEATER423A00	41.7		5.0	38.3	130.7	052	052	052	052		
	CRHEATER424A00	50.0		5.0	45.9	156.7	052	052	052	052		
	CRHEATER420A00	15.0		5.0	13.8	47.0	047	047	047	047		
	HIGH	CRHEATER422A00	33.0	5.0	30.3	103.4	052	052	052	052		
		CRHEATER423A00	41.7	5.0	38.3	130.7	052	052	052	052		
		CRHEATER424A00	50.0	5.0	45.9	156.7	052	052	052	052		
		CRHEATER425A00	18.0	5.0	16.5	56.4	047	047	047	047		
	575-3-60	STD/ MED	CRHEATER427A00	36.0	5.0	33.1	112.8	052	052	052	052	
			CRHEATER428A00	50.0	5.0	45.9	156.7	052	052	052	052	
			CRHEATER425A00	18.0	5.0	16.5	56.4	047	047	047	047	
		HIGH	CRHEATER427A00	36.0	5.0	33.1	112.8	052	052	052	052	
			CRHEATER428A00	50.0	5.0	45.9	156.7	052	052	052	052	
CRHEATER428A00			50.0	5.0	45.9	156.7	052	052	052	052		

RHV090-102 Control Wiring Diagram, Electro-Mechanical with W7220 Controller

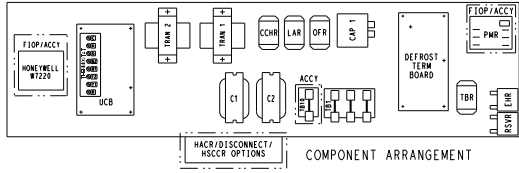

- NOTES:
1. UCB LAYOUT DOES NOT MATCH ACTUAL TERMINAL BOARD LAYOUT.
 2. TERMINAL BOARD JUMPERS 1, 2 AND 3 ARE CUT FROM THE FACTORY.
 3. REMOVE DESIGNATED JUMPERS ON TERMINAL BOARD WHEN ADDING SMOKE DETECTORS, OCCUPANCY AND REMOTE SHUTDOWN.
 4. USE ABC AS COARSE AND POT AS FINE ADJUSTMENTS FOR SETTING HIGH FAN SPEED. LOW SPEED IS AN OFFSET BASED ON DIP SWITCHES.
 5. 2-PIN LOW SPEED DIP SWITCH POSITIONS ARE FACTORY SET AS SHOWN. HARDSTART AND CUTOFF SET TO "MIN". JUMPER PIN ON TOP 2-PIN AS SHOWN.
 6. WIRE COLOR IS FOR DIFFERENTIATION WITHIN THIS SCHEMATIC. TRANSFORMER IS DEDICATED BASED ON UNIT VOLTAGE. TAPS ONLY SHOWN TO SIMPLIFY SCHEMATIC. 200V/230V UNIT TAP IS WERD FOR 230V UNIT. UNIT IS TO BE RUN WITH 208V POWER SUPPLY. DISCONNECT BLK WIRE FROM 230V TAP AND CONNECT TO 208V TAP.
 7. TBA LOCATED IN HEAT SECTION.
 8. TO CONVERT TO A SINGLE STAGE HEATER MOVE VIOLET WIRE AT TBA4 TO CONNECT WITH WHITE WIRE.

HP DIP SWITCH SETTINGS

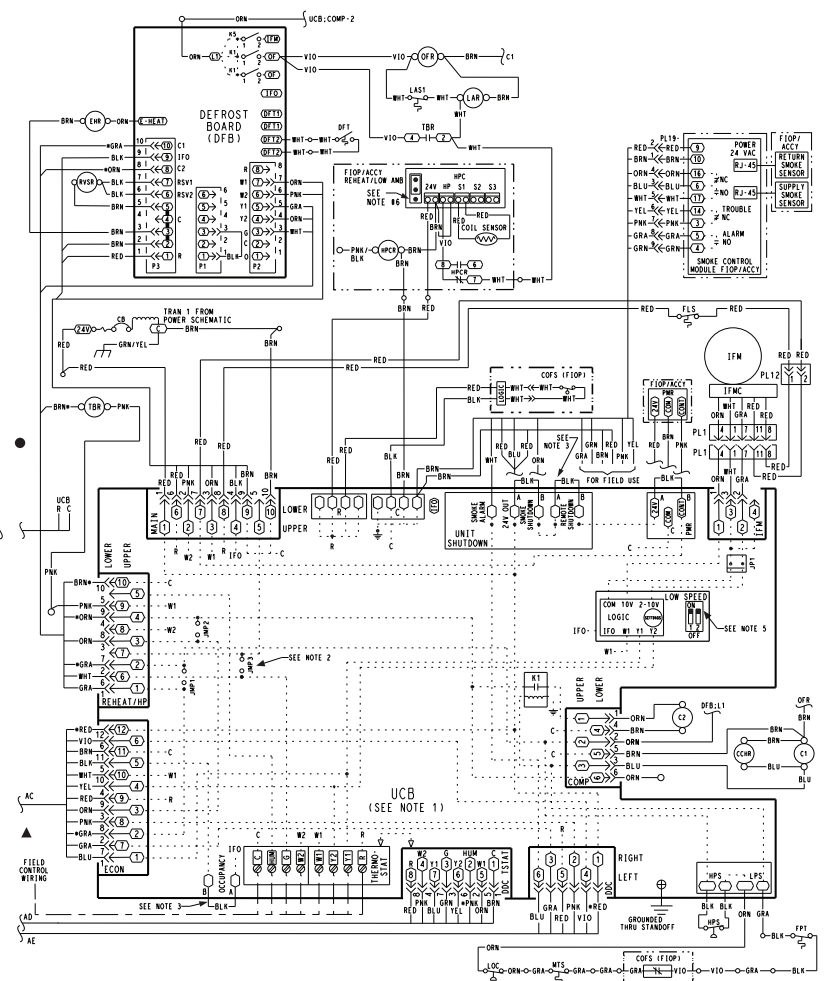
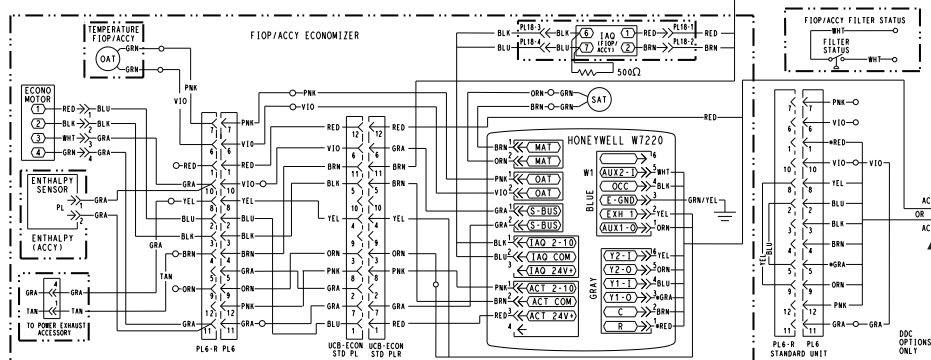
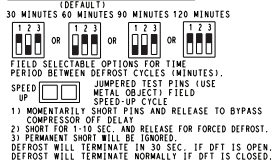

RHV120 Control Wiring Diagram, Electro-Mechanical with W7220 Controller

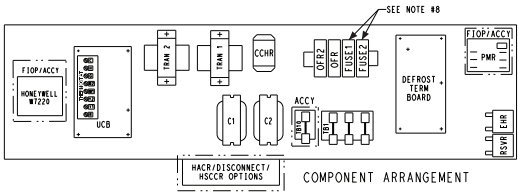

- NOTES:
- UCB SCHEMATIC LAYOUT DOES NOT MATCH ACTUAL TERMINAL BOARD LAYOUT.
 - TERMINAL BOARD JUMPERS 1, 2 AND 3 ARE CUT FROM THE FACTORY.
 - REMOVE DESIGNATED JUMPERS ON UCB WHEN ADDING SMOKE DETECTORS, OCCUPANCY AND REMOTE SHUTDOWN.
 - USE ABC AS COARSE AND POT AS FINE ADJUSTMENTS FOR SETTING HIGH FAN SPEED. LOW SPEED IS AN OFFSET BASED ON DIP SWITCHES.
 - 2-PIN LOW SPEED DIP SWITCH POSITIONS ARE FACTORY SET AS SHOWN.
 - HARDSTART AND CUTOFF SET TO "MIN" - JUMPER PIN ON TOP 2-PINS AS SHOWN.
 - THE * WIRE COLOR IS FOR DIFFERENTIATION WITHIN THIS SCHEMATIC.
 - FUSES FOR 230V ARE LOCATED IN CONTROL BOX. FUSES FOR 460/575V ARE LOCATED BELOW THE CONTROL BOX.
 - TBA LOCATED IN HEAT SECTION.
 - TO CONVERT TO A SINGLE STAGE HEATER MOVE VIOLET WIRE AT TBA TO CONNECT WITH WHITE WIRE.
 - TRANSFORMER IS DEDICATED BASED ON UNIT VOLTAGE. TAPS ONLY SHOWN.
 - TO SIMPLIFY SCHEMATIC, 200/230V UNIT TAP IS WIDED FOR 230V UNIT. IF UNIT IS TO BE RUN WITH 200V POWER SUPPLY DISCONNECT BLK WIRE FROM 230V TAP AND CONNECT TO 200V TAP.

HP DIP SWITCH SETTINGS

(DEFAULT)

30 MINUTES 60 MINUTES 90 MINUTES 120 MINUTES

FIELD SELECTABLE OPTIONS FOR TIME PERIOD BETWEEN DEFROST CYCLES (MINUTES).

SPEED UP CYCLE

METAL OBJECT FIELD

1) MOMENTARILY SHORT PINS AND RELEASE TO BYPASS COMPRESSOR OFF DELAY.

2) SHORT FOR 1-10 SEC. AND RELEASE FOR FORCED DEFROST.

3) PERMANENT SHORT WILL BE IGNORED.

DEFROST WILL TERMINATE IN 30 SEC. IF DFT IS OPEN.

DEFROST WILL TERMINATE NORMALLY IF DFT IS CLOSED.

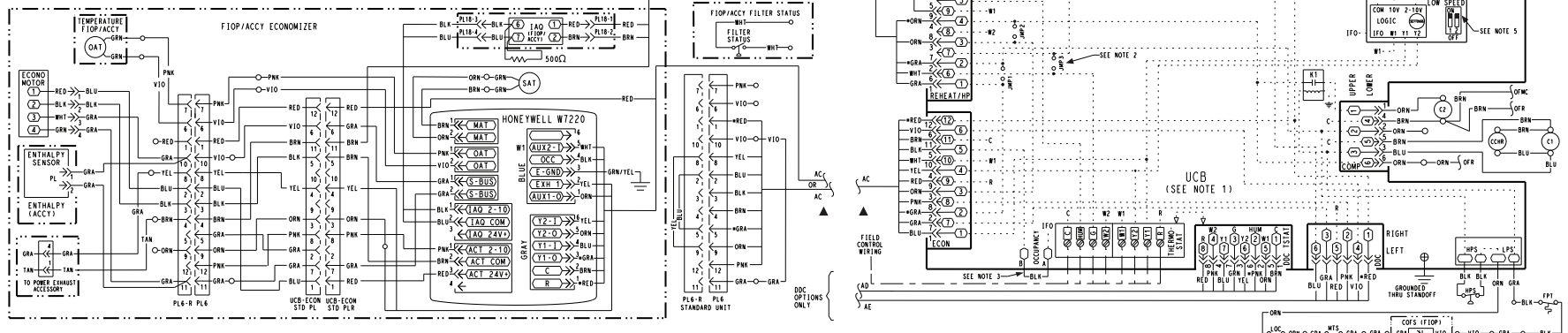
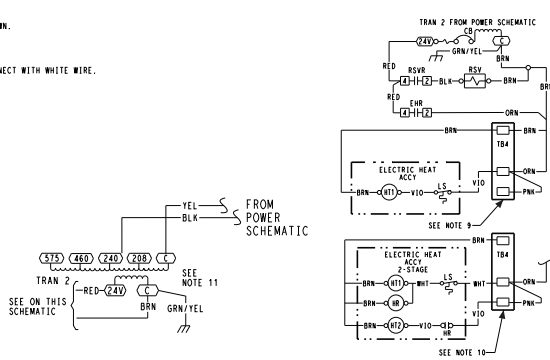

HP CONTROL 230/460/575V T1 10 TON

Typical wiring diagrams (cont)

RHV090-102 Power Wiring Diagram, 230/460V-3-60 Shown

HP POWER 230/460V T1 7.5-8.5 TON

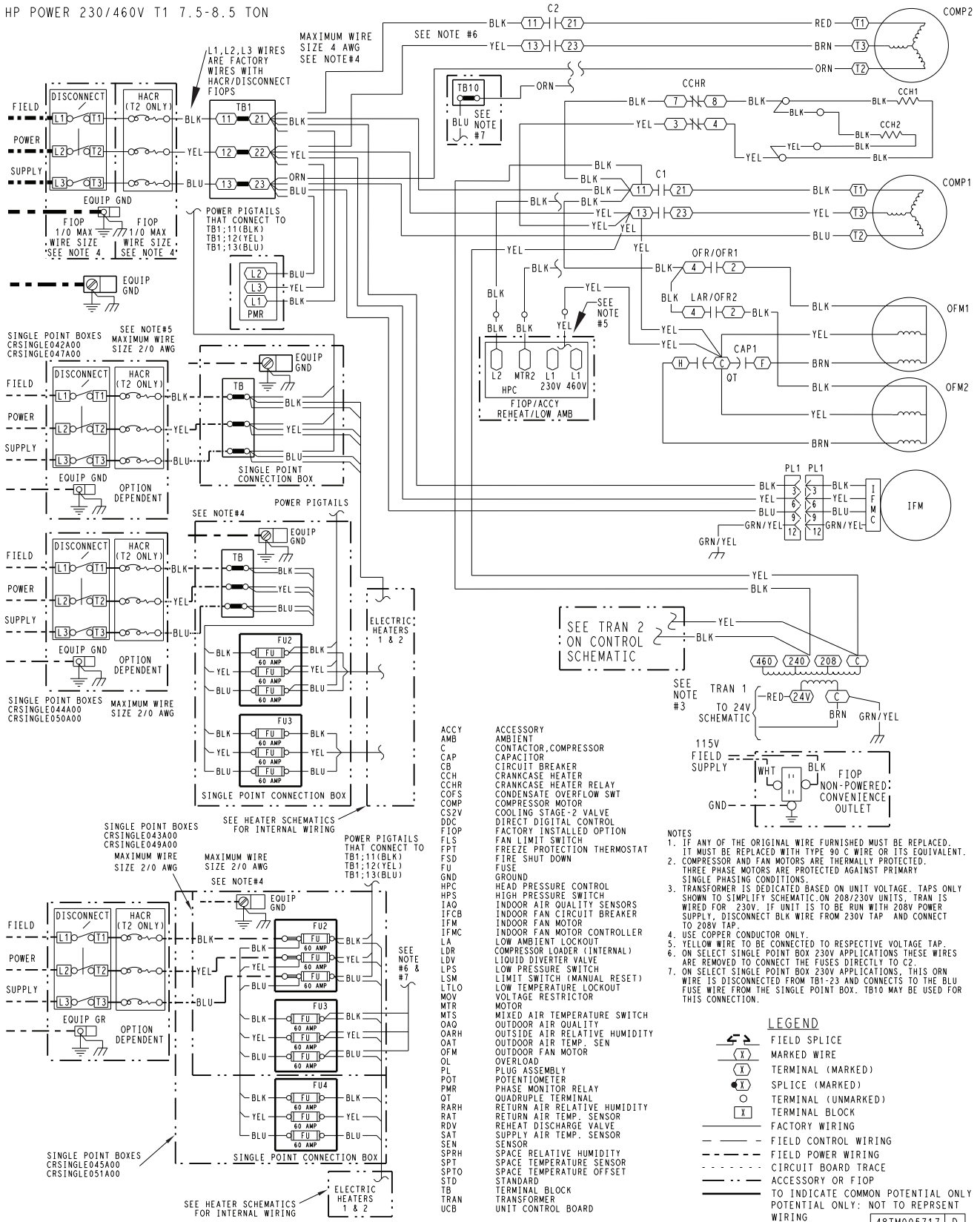

RHV150 Control Wiring Diagram, Electro-Mechanical with W7220 Controller

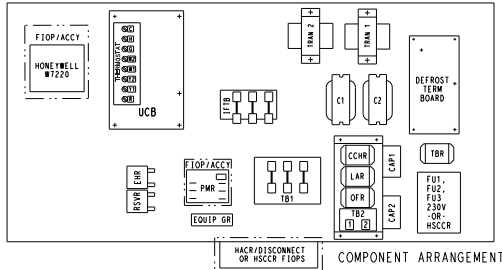

- NOTES:
1. UCB LAYOUT DOES NOT MATCH ACTUAL TERMINAL BOARD LAYOUT.
 2. TERMINAL BOARD JUMPERS 1, 2 AND 3 ARE CUT FROM THE FACTORY.
 3. REMOVE DESIGNATED JUMPERS ON TERMINAL BOARD WHEN ADDING SMOKE DETECTORS, OCCUPANCY AND REMOTE SHUTDOWN.
 4. USE ABC AS COARSE AND POT AS FINE ADJUSTMENTS FOR SETTING HIGH FAN SPEED. LOW SPEED IS AN OFFSET BASED ON DIP SWITCHES.
 5. 2-PIN LOW SPEED DIP SWITCH POSITIONS ARE FACTORY SET AS SHOWN.
 6. HARDSTART AND CUTOFF SET TO "MIN". JUMPER PIN ON TOP 2-PINS AS SHOWN.
 7. TRANSFORMER IS DEDICATED BASED ON UNIT VOLTAGE. TAPS ONLY SHOWN TO SIMPLIFY SCHEMATIC. 208/230V UNIT TRAN IS WIRED FOR 230V UNIT. IF UNIT IS TO BE RUN WITH 208V POWER SUPPLY DISCONNECT BLK WIRE FROM 230V TAP AND CONNECT TO 208V TAP.
 8. TBA LOCATED IN HEAT SECTION.

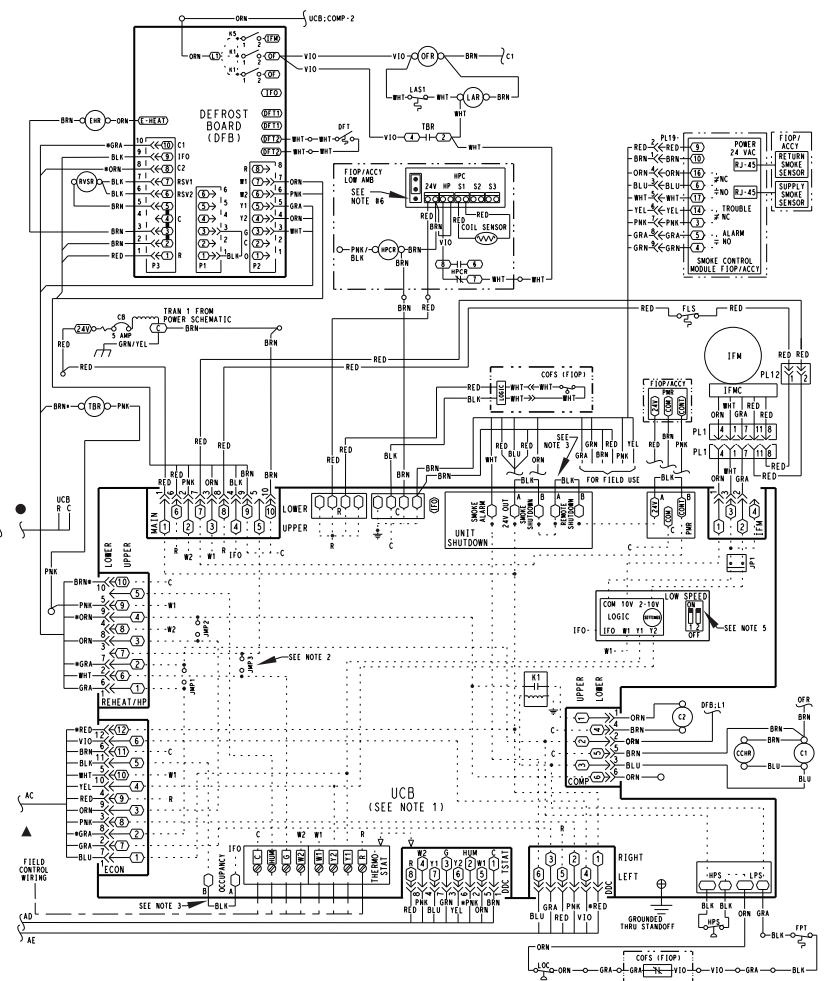
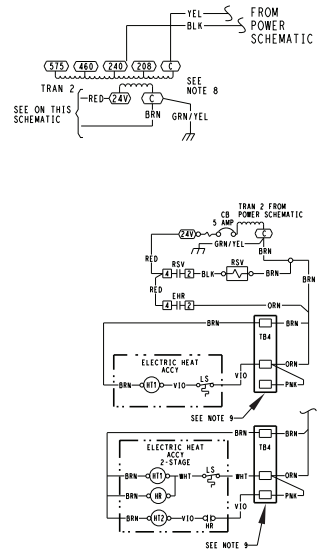
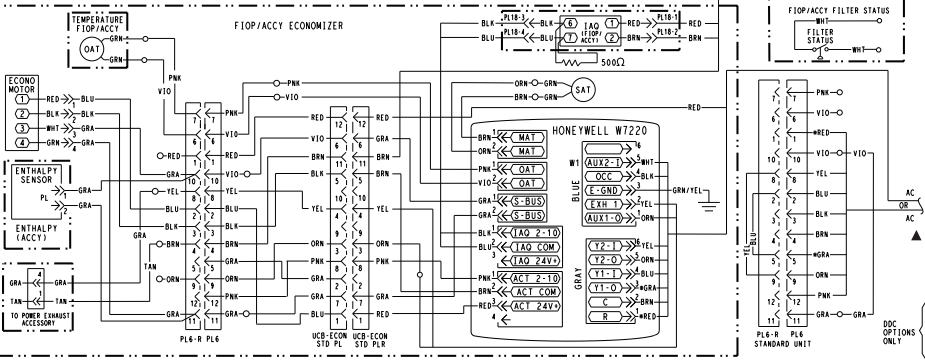
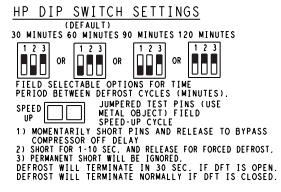

HP CONTROL 230/460/575V T1 12.5 TON

50TM002446

Typical wiring diagrams (cont)

RHV150 Power Wiring Diagram, 208/230, 460V-3-60 Shown

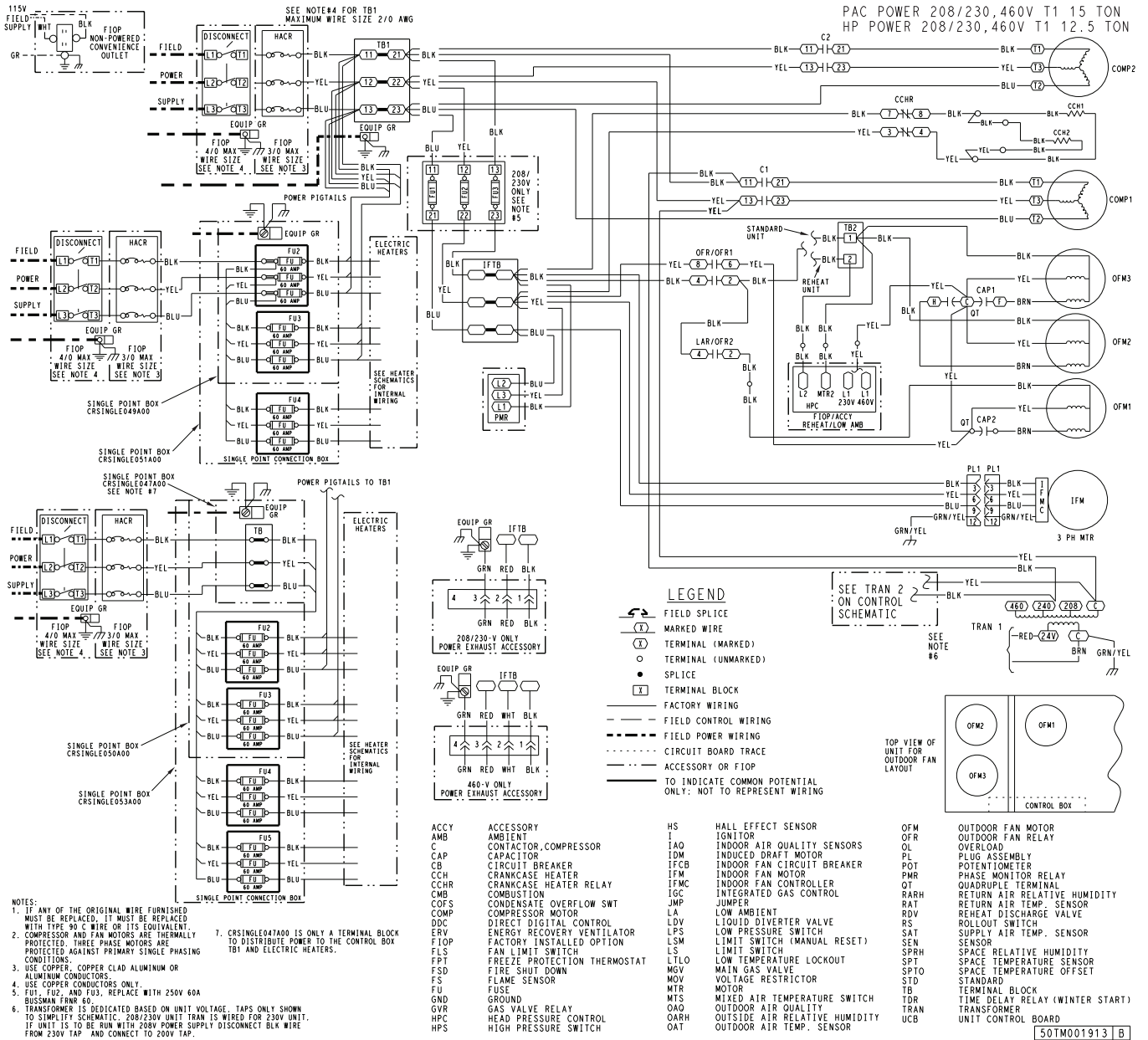

Typical wiring diagrams (cont)

RHV150 Power Wiring Diagram, 575V-3-60 Shown

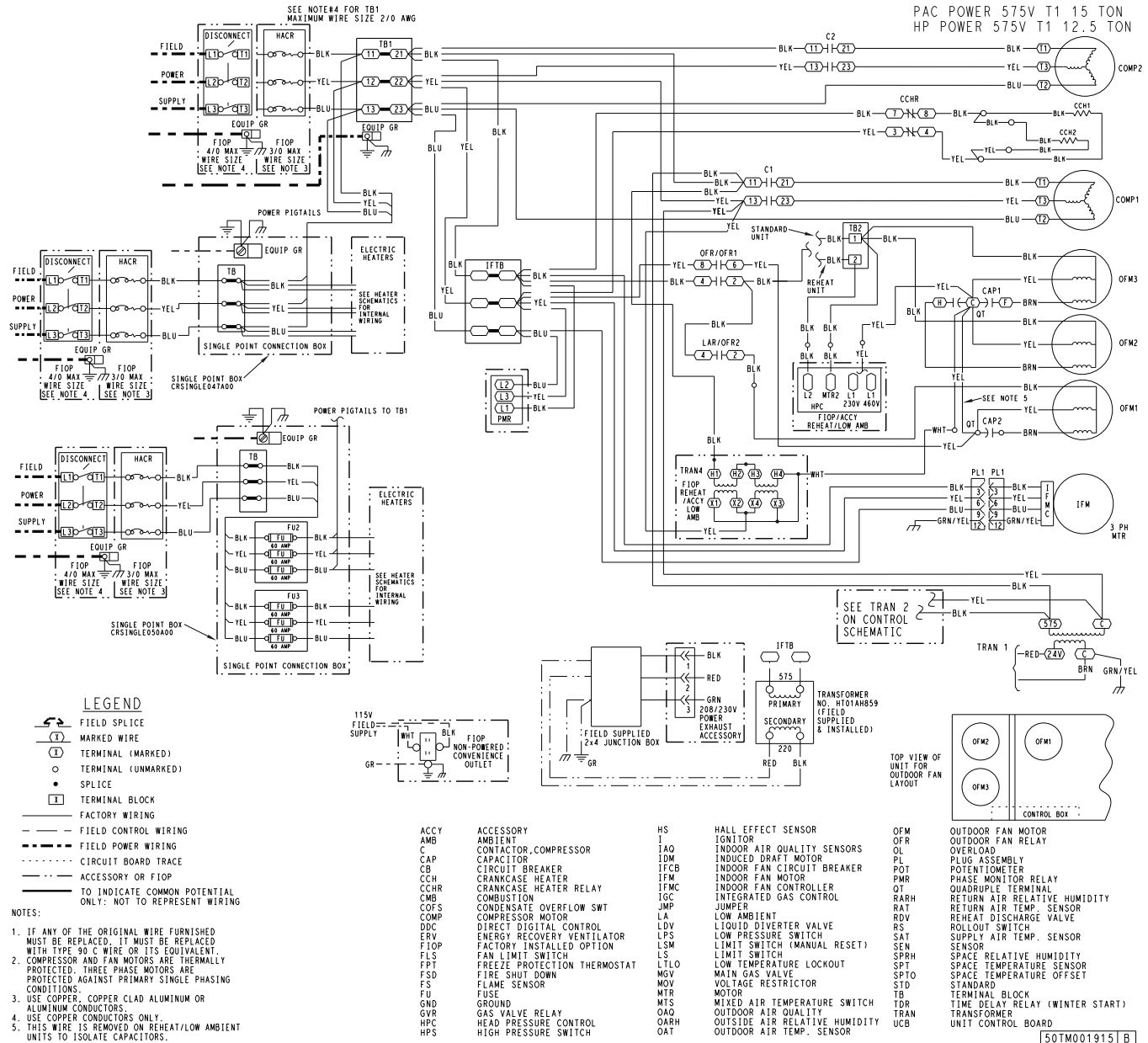

Sequence of operation

General

The sequence below describes the sequence of operation for an electro-mechanical unit with and without a factory-installed EconoMi\$er® IV (W7212 controller) and X (W7220 controller). For information regarding a direct digital controller, see the start-up, operations, and troubleshooting manual for the applicable controller.

Electro-Mechanical Units with No Economizer

Cooling

When the thermostat calls for cooling, terminals G and Y1 are energized. The indoor fan will run at the low fan speed and the compressor contactor (CC) is energized causing the compressor and outdoor fan to run. The low indoor fan speed is 66% of the user set fan speed and the compressor will run at partial capacity.

If additional cooling is needed, the thermostat will add the call for Y2. This will increase the indoor fan speed to the user set fan speed and energize the compressor loader for full compressor capacity. The outdoor fan is the same speed for Y1 and Y2.

When the thermostat removes the call for Y2 but leaves the Y1, the indoor fan will reduce speed to 66% of the user set fan speed, the compressor loader will turn off, and the outdoor fan will remain on. When the thermostat removes the call for Y1 the compressor contactor will de-energize shutting down the compressor and the outdoor fan. When the thermostat removes the call for G, the indoor fan will turn off after the specific unit fan off delay.

NOTE: Per ASHRAE 90.1-2019 and IECC-2018 standards, during the first stage of cooling operation the Unit Control Board (UCB) will adjust the fan motor speed to provide 66% of the total cfm established for the unit.

Defrost

When the temperature of the outdoor coil drops below 28°F (-2°C) as sensed by the defrost thermostat (DFT2) and the defrost timer is at the end of a timed period (adjustable at 30, 60, 90 or 120 minutes), reversing valve solenoids (RVS1 and RVS2) are energized and the OFC is de-energized. This switches the position of the reversing valves and shuts off the outdoor fan. The electric heaters (if installed) will be energized.

Heating, unit with economizer

When the room temperature calls for heat through terminal W1, the indoor (evaporator) fan contactor (IFC) and heater contactor no. 1 (HC1) are energized and the reversing valve(s) de-energize and switches position. On units equipped for 2 stages of heat, when additional heat is needed, heater contactor no. 2 is energized through W2. The economizer damper moves to the minimum position. When the thermostat is satisfied, the damper moves to the fully closed position.

Heating, unit without economizer

Upon a request for heating from the space thermostat, terminal W1 will be energized with 24V. The IFC, outdoor fan contactor (OFC), C1, and C2 will be energized. The

indoor fan, outdoor fans, and compressor no. 1, and compressor no. 2 are energized and reversing valves are de-energized and switch position.

If the space temperature continues to fall while W1 is energized, W2 will be energized with 24V, and the heater contactor(s) (HC) will be energized, which will energize the electric heater(s).

When the space thermostat is satisfied, W2 will be de-energized first, and the electric heater(s) will be de-energized. Upon a further rise in space temperature, W1 will be de-energized.

IMPORTANT: The thermostat must be configured for Electric Heat so it will energize G with the W1 call.

Electro-Mechanical Units with Factory-Installed EconoMi\$er

When free cooling is not available, the compressors will be controlled by the zone thermostat. When free cooling is available, the outdoor-air damper is modulated by the EconoMi\$er IV and X control to provide a 50°F (10°C) to 55°F (13°C) mixed-air temperature into the zone. As the mixed air temperature fluctuates above 55°F (13°C) or below 50°F (10°C) dampers will be modulated (open or close) to bring the mixed-air temperature back within control. If mechanical cooling is utilized with free cooling, the outdoor-air damper will maintain its current position at the time the compressor is started. If the increase in cooling capacity causes the mixed-air temperature to drop below 45°F (7°C), then the outdoor-air damper position will be decreased to the minimum position. If the mixed-air temperature continues to fall, the outdoor-air damper will close. Control returns to normal once the mixed-air temperature rises above 48°F (9°C). The power exhaust fans will be energized and de-energized, if installed, as the outdoor-air damper opens and closes.

If field-installed accessory CO₂ sensors are connected to the EconoMi\$er IV and X control, a demand controlled ventilation strategy will begin to operate. As the CO₂ level in the zone increases above the CO₂ set-point, the minimum position of the damper will be increased proportionally. As the CO₂ level decreases because of the increase in fresh air, the outdoor-air damper will be proportionally closed. For EconoMi\$er IV and X operation, there must be a thermostat call for the fan (G). If the unit is occupied and the fan is on, the damper will operate at minimum position. Otherwise, the damper will be closed.

When the EconoMi\$er IV and X control is in the occupied mode and a call for cooling exists (Y1 on the thermostat), the control will first check for indoor fan operation. If the fan is not on, then cooling will not be activated. If the fan is on, then the control will open the EconoMi\$er IV and X damper to the minimum position.

On the initial power to the EconoMi\$er IV and X control, it will take the damper up to 2 1/2 minutes before it begins to position itself. After the initial power-up, further changes in damper position can take up to 30 seconds to initiate. Damper movement from full closed to full open (or vice versa) will take between 1 1/2 and 2 1/2 minutes.

Sequence of operation (cont)

If free cooling can be used as determined from the appropriate changeover command (switch, dry bulb, enthalpy curve, differential dry bulb, or differential enthalpy), then the control will modulate the dampers open to maintain the mixed-air temperature set-point at 50°F (10°C) to 55°F (13°C). If there is a further demand for cooling (cooling second stage — Y2 is energized), then the control will bring on compressor stage 1 to maintain the mixed-air temperature set-point. The EconoMiSer® IV and X damper will be open at maximum position.

2-Speed Note: The EconoMiSer® IV and X controller will adjust the damper position as the Indoor Fan Speed changes, per its configured values.

Heating

The sequence of operation for the heating is the same as an electro-mechanical unit with no economizer. The only difference is how the economizer acts. The economizer will stay at the Economizer Minimum Position while the evaporator fan is operating. The outdoor-air damper is closed when the indoor fan is not operating. Refer to Service and Maintenance Manual for further details.

Application data

Minimum operating ambient temperature (cooling)

In mechanical cooling mode, your RHV rooftop unit can safely operate down to an outdoor ambient temperature of 40°F (4°C) [0°F (-18°C) for size 120 models]. It is possible to provide cooling at lower outdoor ambient temperatures by using less outside air, economizers, and/or accessory low ambient kits.

Maximum operating ambient temperature (cooling)

The maximum operating ambient temperature for cooling mode is 125°F (52°C). While cooling operation above 125°F (52°C) may be possible, it could cause either a reduction in performance, reliability, or a protective action by the unit's internal safety devices.

Multiple motor and drive packages

Some applications need larger horsepower motors, some need more airflow, and some need both. Regardless of the case, we have a factory installed combination to meet your application. A wide selection of motors are available, factory installed, to handle nearly any application.

Minimum and maximum airflow (heating and cooling)

To maintain safe and reliable operation of your rooftop, operate within the heating airflow limits during heating mode and cooling airflow limits during cooling mode. Operating above the max may cause blow-off, undesired airflow noise, or airflow related problems with the rooftop unit. Operating below the min may cause problems with coil freeze-up and unsafe heating operation. Heating and cooling limitations differ when evaluating operating cfm, minimum value is the HIGHER of the cooling and heating minimum cfm values published on page 5 and the maximum value is the LOWER of the cooling and heating maximum values published on page 5.

Heating-to-cooling changeover

Your unit will automatically change from heating to cooling mode when using a thermostat with an auto-change-over feature.

Airflow

All units are draw-through in cooling mode and blow-through in heating mode.

Outdoor air application strategies

Economizers reduce operating expenses and compressor run time by providing a free source of cooling and a means of ventilation to match application changing needs. In fact, they should be considered for most

applications. Also, consider the various economizer control methods and their benefits, as well as sensors required to accomplish your application goals. Please contact your local company representative for assistance.

Motor limits, brake horsepower (bhp)

Due to internal design of RHV units, the air path, and specially designed motors, the full horsepower (maximum continuous bhp) band, as listed in the Fan Performance tables, can be used with the utmost confidence. There is no need for extra safety factors, as our motors are designed and rigorously tested to use the entire, listed bhp range without either nuisance tripping or premature motor failure.

Sizing a rooftop

Bigger is not necessarily better. While an air conditioner needs to have enough capacity to meet the design loads, it does not need excess capacity. In fact, excess capacity typically results in very poor part load performance and humidity control.

Using higher design temperatures than ASHRAE recommends for your location, adding "safety factors" to the calculated load, are all signs of oversizing air conditioners. Oversizing the air conditioner leads to poor humidity control, reduced efficiency, higher utility bills, larger indoor temperature swings, excessive noise, and increased wear and tear on the air conditioner.

Rather than oversizing an air conditioner, engineers should "right-size" or even slightly "under-size" air conditioners. Correctly sizing an air conditioner controls humidity better; promotes efficiency; reduces utility bills; extends equipment life, and maintains even, comfortable temperatures. Please contact your local company representative for assistance.

Low ambient applications

The optional economizer can adequately cool your space by bringing in fresh, cool outside air. In fact, when so equipped, accessory low-ambient kit may not be necessary. In low ambient conditions, unless the outdoor air is excessively humid or contaminated, economizer-based "free cooling" is the preferred less costly and energy conscious method. In low ambient applications where outside air might not be desired (such as contaminated or excessively humid outdoor environments), your RHV rooftop can operate to ambient temperatures down to 0°F (-18°C) using the recommended accessory low ambient controller.

NOTE: 0°F (-18°C) is standard on size 120 models.

Guide specifications

This specification is in the "Masterformat" as published by the Construction Specification Institute. Please feel free to copy this specification directly into your building spec.

Rooftop Packaged Heat Pump

HVAC Guide Specifications

Size Range: **7.5 to 12.5 Nominal Tons**

Model Number: **RHV090-150**

Part 1 — (23 06 80) Schedules for Decentralized HVAC Equipment

1.01 (23 06 80.13) Decentralized Unitary HVAC Equipment Schedule:

- A. (23 06 80.13.A.) Rooftop unit (RTU) schedule:
1. Schedule is per the project specification requirements.

Part 2 — (23 07 16) HVAC equipment insulation

2.01 (23 07 16.13) Decentralized, Rooftop Units:

- A. (23 07 16.13.A.) Evaporator fan compartment:
1. Interior cabinet surfaces shall be insulated with a minimum 1/2 in. thick, minimum 1-1/2 lb density, flexible fiberglass insulation bonded with a phenolic binder, neoprene coated on the air side.
 2. Insulation and adhesive shall meet NFPA 90A requirements for flame spread and smoke generation.
- B. (23 07 16.13.B.) Electric Heat Compartment:
1. Aluminum foil-faced fiberglass insulation shall be used.
 2. Insulation and adhesive shall meet NFPA 90A requirements for flame spread and smoke generation.

Part 3 — (23 09 13) Instrumentation and control devices for HVAC

3.01 (23 09 13.13) Sensors and Transmitters:

- A. (23 09 13.13.A.) Thermostats:
1. Thermostat must
 - a. have capability to energize 2 different stages of cooling, and 2 different stages of heating.
 - b. be heat pump design and include capability for occupancy scheduling.

Part 4 — (23 09 23) (23 09 33) Electric and Electronic Control System for HVAC

4.01 (23 09 33.13) Decentralized, Rooftop Units:

- A. (23 09 33.13.A.) General:
1. Shall be complete with self-contained low-voltage control circuit protected by a resettable circuit breaker on the 24-v transformer side. Transformer shall have 75VA capability.
 2. Shall utilize color-coded wiring.

3. Shall include a Unit Control Board to conveniently and safely provide connection points for vital control functions such as: smoke detectors, phase monitor, economizer, thermostat, and low and high pressure switches. Controller shall also provide an intuitive means to adjust the indoor fan speed through a simple switch and pot adjustment design.

4. Unit shall include a minimum of one 8-pin screw terminal connection board for connection of control wiring.

5. Shall include integrated defrost system to prevent excessive frost accumulation during heating duty, and shall be controlled as follows:

- a. Defrost shall be initiated on the basis of time and coil temperature.
- b. A 30, 60, 90, 120 minute timer shall activate the defrost cycle only if the coil temperature is low enough to indicate a heavy frost condition.
- c. Defrost cycle shall terminate when defrost thermostat is satisfied and shall have a positive termination time of 10 minutes.

6. Defrost system shall also include:

- a. Defrost Cycle Indicator LED.
- b. Dip switch selectable defrost time between 30, 60, 90 and 120 minutes. Factory set at 30 minutes.
- c. Molded plug connection to ensure proper connection.

B. (23 09 33.13.B.) Safeties:

1. Compressor over-temperature, over-current. High internal pressure differential.
2. Low pressure switch.
 - a. Low pressure switch shall use different color wire than the high pressure switch. The purpose is to assist the installer and service technician to correctly wire and or troubleshoot the rooftop unit.
3. High pressure switch.
 - a. High pressure switch shall use different color wire than the low pressure switch. The purpose is to assist the installer and service technician to correctly wire and or troubleshoot the rooftop unit.
4. Automatic reset, motor thermal overload protector.

Part 5 — (23 09 93) Sequence of Operations for HVAC Controls

5.01 (23 09 93.13) Decentralized, Rooftop Units:

- A. (23 09 93.13.A.) INSERT SEQUENCE OF OPERATION

Guide specifications (cont)

Part 6 — (23 40 13) Panel Air Filters

6.01 (23 40 13.13) Decentralized, Rooftop Units:

- A. (23 40 13.13.A.) Standard filter section:
1. Shall consist of factory installed, low velocity, disposable 2-in. thick fiberglass filters of commercially available sizes.
 2. Unit shall use only one filter size. Multiple sizes are not acceptable.
 3. Filters shall be accessible through an access panel with “no-tool” removal as described in the unit cabinet section of this specification (23 81 19.13.G).

Part 7 — (23 81 19) Self-Contained Air Conditioners

7.01 (23 81 19.13) Small-Capacity Self-Contained Air Conditioners (RHV090-150):

- A. (23 81 19.13.A.) General:
1. Outdoor, rooftop mounted, electrically controlled, heating and cooling unit utilizing a fully hermetic scroll compressor(s) for cooling duty and heat pump heating duty.
 2. Factory assembled, single-piece heating and cooling rooftop unit. Contained within the unit enclosure shall be all factory wiring, piping, controls, and special features required prior to field start-up.
 3. Unit shall use R-410A refrigerant.
 4. Unit shall be installed in accordance with the manufacturer’s instructions.
 5. Unit must be selected and installed in compliance with local, state, and federal codes.
- B. (23 81 19.13.B.) Quality Assurance:
1. Unit meets ASHRAE 90.1 minimum efficiency requirements.
 2. Unit shall be rated in accordance with AHRI Standards 340/360.
 3. Unit shall be designed to conform to ASHRAE 15.
 4. Unit shall be UL-tested and certified in accordance with ANSI Z21.47 Standards and UL-listed and certified under Canadian standards as a total package for safety requirements.
 5. Insulation and adhesive shall meet NFPA 90A requirements for flame spread and smoke generation.
 6. Unit casing shall be capable of withstanding 500 hour salt spray exposure per ASTM B117 (scribed specimen).
 7. Unit shall be designed in accordance with ISO 9001, and shall be manufactured in a facility registered by ISO 9001:2015.
 8. Roof curb shall be designed to conform to NRCA Standards.
 9. Unit shall be subjected to a completely automated run test on the assembly line. The data

for each unit will be stored at the factory, and must be available upon request.

10. Unit shall be designed in accordance with UL Standard 1995, including tested to withstand rain.
 11. Unit shall be constructed to prevent intrusion of snow and tested to prevent snow intrusion into the control box up to 40 mph.
 12. Unit shall be tested to assurance level 1, ASTM D4169 to ensure shipping reliability.
- C. (23 81 19.13.C.) Delivery, Storage, and Handling:
1. Unit shall be stored and handled per manufacturer’s recommendations.
 2. Lifted by crane requires either shipping top panel or spreader bars.
 3. Unit shall only be stored or positioned in the upright position.
- D. (23 81 19.13.D.) Project Conditions:
1. As specified in the contract.
- E. (23 81 19.13.E.) Operating Characteristics:
1. Unit shall be capable of starting and running at 125°F (52°C) ambient outdoor temperature meeting maximum load criteria of AHRI Standard 340/360 at ±10% voltage.
 2. Compressor with standard controls shall be capable of operation down to 40°F (4°C) [0°F (–18°C) for size 120 models], ambient outdoor temperatures. Accessory winter start kit is necessary if mechanically cooling at ambient temperatures down to 25°F (–4°C) or 0°F (–18°C).
 3. Unit shall discharge supply air vertically or horizontally as shown on contract drawings.
 4. Unit shall be factory configured for vertical supply and return configurations.
 5. Unit shall be field convertible from vertical to horizontal airflow on all models. No special kit required except on 150 size models that requires a Supply Duct Kit field installation for horizontal air flow.
 6. Unit shall be capable of mixed operation: vertical supply with horizontal return or horizontal supply with vertical return.
- F. (23 81 19.13.F.) Electrical Requirements:
1. Main power supply voltage, phase, and frequency must match those required by the manufacturer.
- G. (23 81 19.13.G.) Unit Cabinet:
1. Unit cabinet shall be constructed of galvanized steel, and shall be bonderized and coated with a prepainted baked enamel finish on all externally exposed surfaces.
 2. Unit cabinet exterior paint shall be: film thickness, (dry) 0.003 in. minimum, gloss (per ASTM D523, 60°F/16°C): 60, Hardness: H-2H Pencil hardness.

Guide specifications (cont)

3. Evaporator fan compartment interior cabinet insulation shall conform to AHRI Standards 340/360 minimum exterior sweat criteria. Interior surfaces shall be insulated with a minimum 1/2 in. thick, 1 lb density, flexible fiberglass insulation, neoprene coated on the air side. Aluminum foil-faced fiberglass insulation shall be used in the heat compartment.
4. Base of unit shall have a minimum of 4 locations for thru-the-base gas and electrical gauge connections (factory-installed or field-installed), standard.
5. Base Rail:
 - a. Unit shall have base rails on a minimum of 2 sides.
 - b. Holes shall be provided in the base rails for rigging shackles to facilitate maneuvering and overhead rigging.
 - c. Holes shall be provided in the base rail for moving the rooftop by fork truck.
 - d. Base rail shall be a minimum of 16 gauge thickness.
6. Condensate pan and connections:
 - a. Shall be a sloped condensate drain pan made of a corrosion resistant material.
 - b. Shall comply with ASHRAE Standard 62.
 - c. Shall use a 3/4 in. 14 NPT drain connection, possible either through the bottom or side of the drain pan. Connection shall be made per manufacturer's recommendations.
7. Top panel:
 - a. Shall be a single piece top panel on 090-120 models and 2 piece on 150 size models.
8. Electrical Connections:
 - a. All unit power wiring shall enter unit cabinet at a single, factory prepared, knockout location.
 - b. Thru-the-base capability.
 - c. Standard unit shall have a thru-the-base electrical location(s) using a raised, embossed portion of the unit basepan.
 - d. Optional, factory approved, water-tight connection method must be used for thru-the-base electrical connections.
 - e. No basepan penetration, other than those authorized by the manufacturer, is permitted.
9. Component access panels (standard):
 - a. Cabinet panels shall be easily removable for servicing.
 - b. Unit shall have one factory installed, tool-less, removable, filter access panel.
 - c. Panels covering control box, indoor fan, indoor fan motor, gas components (where applicable), and compressors shall have molded composite handles.

- d. Handles shall be UV modified, composite. They shall be permanently attached, and recessed into the panel.
 - e. Screws on the vertical portion of all removable access panel shall engage into heat resistant, molded composite collars.
 - f. Collars shall be removable and easily replaceable using manufacturer recommended parts.
- H. (23 81 19.13.H.) Coils:
1. Standard industry proven Aluminum Fin-Copper Tube Coils:
 - a. Standard evaporator and condenser coils shall have aluminum lanced plate fins mechanically bonded to seamless internally grooved copper tubes with all joints brazed.
 - b. Evaporator coils shall be leak tested to 150 psig, pressure tested to 450 psig, and qualified to UL 1995 burst test at 1775 psig.
 - c. Condenser coils shall be leak tested to 150 psig, pressure tested to 650 psig, and qualified to UL 1995 burst test at 1980 psig.
 2. Optional Pre-coated aluminum-fin condenser coils:
 - a. Shall have a durable epoxy-phenolic coating to provide protection in mildly corrosive coastal environments.
 - b. Coating shall be applied to the aluminum fin stock prior to the fin stamping process to create an inert barrier between the aluminum fin and copper tube.
 - c. Epoxy-phenolic barrier shall minimize galvanic action between dissimilar metals.
 - d. Corrosion durability of fin stock shall be confirmed through testing to be no less than 1000 hours salt spray per ASTM B117-90.
 - e. Corrosion durability of fin stock shall be confirmed through testing to have no visible corrosion after 48 hour immersion in a room temperature solution of 5% salt, 1% acetic acid.
 - f. Fin stock coating shall pass 2000 hours of the following: one week exposure in the prohesion chamber followed by one week of accelerated ultraviolet light testing. Prohesion chamber: the solution shall contain 3.5% sodium chloride and 0.35% ammonium sulfate. The exposure cycle is one hour of salt fog application at ambient followed by one hour drying at 95°F (35°C).
 3. Optional Copper-fin evaporator and condenser coils:
 - a. Shall be constructed of copper fins mechanically bonded to copper tubes and copper tube sheets.
 - b. Galvanized steel tube sheets shall not be acceptable.

Guide specifications (cont)

- c. A polymer strip shall prevent coil assembly from contacting the sheet metal coil pan to minimize potential for galvanic corrosion between coil and pan.
- 4. Optional E-coated aluminum-fin evaporator and condenser coils:
 - a. Shall have a flexible epoxy polymer coating uniformly applied to all coil surface areas without material bridging between fins.
 - b. Coating process shall ensure complete coil encapsulation of tubes, fins and headers.
 - c. Color shall be high gloss black with gloss per ASTM D523-89.
 - d. Uniform dry film thickness from 0.8 to 1.2 mil on all surface areas including fin edges.
 - e. Superior hardness characteristics of 2H per ASTM D3363-92A and cross-hatch adhesion of 4B-5B per ASTM D3359-93.
 - f. Impact resistance shall be up to 160 in.-lb (ASTM D2794-93).
 - g. Humidity and water immersion resistance shall be up to minimum 1000 and 250 hours respectively (ASTM D2247-92 and ASTM D870-92).
 - h. Corrosion durability shall be confirmed through testing to be no less than 1000 hours salt spray per ASTM B117-90.
- I. (23 81 19.13.I.) Refrigerant Components:
 - 1. Refrigerant circuit shall include the following control, safety, and maintenance features:
 - a. Thermostatic Expansion Valve (TXV) shall help provide optimum performance across the entire operating range. Shall contain removable power element to allow change out of power element and bulb without removing the valve body.
 - b. Refrigerant filter drier - Solid core design.
 - c. Service gauge connections on suction and discharge lines.
 - d. Pressure gauge access through a specially designed access port in the top panel of the unit.
 - e. Suction line accumulator to provide protection in all operating modes from cooling, heating and reverse cycle switching.
 - 2. There shall be gauge line access port in the skin of the rooftop, covered by a black, removable plug.
 - a. The plug shall be easy to remove and replace.
 - b. When the plug is removed, the gauge access port shall enable maintenance personnel to route their pressure gauge lines.
 - c. This gauge access port shall facilitate correct and accurate condenser pressure readings by enabling the reading with the compressor access panel on.
- d. The plug shall be made of a leak proof, UV-resistant, composite material.
- 3. Compressors:
 - a. Unit shall use 2 tandem scroll compressors on single independent refrigeration circuit.
 - b. Units shall have single circuit and 2 stage cooling and contain 2 dual stage compressors.
 - c. Evaporator coils shall be a full active design to help better control comfort latent removal.
 - d. Compressor motors shall be cooled by refrigerant gas passing through motor windings.
 - e. Compressors shall be internally protected from high discharge temperature conditions.
 - f. Compressors shall be protected from an over-temperature and over-amperage conditions by an internal, motor overload device.
 - g. Compressor shall be factory mounted on rubber grommets.
 - h. Compressor motors shall have internal line break thermal, current overload and high pressure differential protection.
 - i. Crankcase heaters shall not be required for normal operating range, unless required by compressor manufacturer due to refrigerant charge limits.
 - j. Compressors shall be a 2 stage cooling capacity design.
- J. (23 81 19.13.J.) Filter Section:
 - 1. Filters access is specified in the unit cabinet section of this specification.
 - 2. Filters shall be held in place by a pivoting filter tray, facilitating easy removal and installation.
 - 3. Shall consist of factory installed, low velocity, throw-away 2-in. thick fiberglass filters.
 - 4. Filters shall be standard, commercially available sizes.
 - 5. Only one size filter per unit is allowed.
- K. (23 81 19.13.K.) Evaporator Fan and Motor with X-Vane Fan Technology:
 - 1. Direct Drive Evaporator fan motor:
 - a. Shall be a ECM motor design.
 - b. Shall have permanently lubricated bearings.
 - c. Shall have inherent automatic-reset thermal overload protection.
 - d. Shall have slow ramp up to speed capabilities.
 - e. Shall require no fan/motor belts for operation, adjustments and or initial fan speed set up.
 - f. Fan DC voltage set up on Unit Control Board can eliminate the need of removal

Guide specifications (cont)

of blower access door, required on conventional belt drive systems.

- g. Shall be internally protected from electrical phase reversal and loss.

2. Evaporator Fan:

- a. Shall be easily set with dedicated selection switch and adjustment pot on unit control board.
- b. Shall provide 2 stage cooling capacity control, the indoor fan speed is automatically controlled to meet the code-compliant <66% low fan speed and 100% at full fan speed operation.
- c. Blower fan shall be a Vane Axial fan design with 75% less moving parts than a conventional belt drive system.
- d. Shall be constructed of a cast aluminum stator and high impact composite material on stator, rotor and air inlet casing.
- e. Shall be a patented/pending design with a corrosion resistant material and dynamically balanced.
- f. Shall have slow ramp up to speed capabilities to help reduce sound and comfort issues typically associated with single speed belt drive systems.
- g. Shall be a slide out design with removal of a few support brackets.

- 3. Shall include an easily accessible Unit Control Board to conveniently and safely provide connection points for vital control functions such as: smoke detectors, phase monitor, economizer, thermostat, and low and high pressure switches. Controller shall also provide an intuitive means to adjust the indoor fan speed through a simple switch and pot adjustment design.

L. (23 81 19.13.L.) Condenser Fans and Motors:

- 1. Condenser fan motors:
 - a. Shall be a totally enclosed motor.
 - b. Shall use permanently lubricated bearings.
 - c. Shall have inherent thermal overload protection with an automatic reset feature.
 - d. Shall use a shaft-down design on all sizes.
- 2. Condenser Fans:
 - a. Shall be a direct-driven propeller type fan constructed of high impact composite material.
 - b. Shall have high impact composite blades completely formed into one piece without blade fasteners or connectors and shall be dynamically balanced.

M. (23 81 19.13.M.) Special Features Options and Accessories:

- 1. Integrated EconoMi\$er® IV and EconoMi\$er X Low Leak rate models. (EconoMi\$er IV is only

available as a field-installed accessory — this design only allows single speed fan operation.)

- a. Integrated, gear driven opposing modulating blade design type capable of simultaneous economizer and compressor operation.
- b. Independent modules for vertical or horizontal return configuration shall be available. Vertical return modules shall be available as a factory installed option.
- c. Damper blades shall be galvanized steel with composite gears. Plastic or composite blades on intake or return shall not be acceptable.
- d. Shall include all hardware and controls to provide free cooling with outdoor air when temperature and/or humidity are below setpoints.
- e. Shall be equipped with gear driven dampers for both the outdoor ventilation air and the return air for positive air stream control.
- f. Standard leak rate shall be equipped with dampers not to exceed 2% leakage at 1 in. wg pressure differential.
- g. Economizer controller on EconoMi\$er IV models shall be Honeywell W7212 that provides:
 - 1) Combined minimum and DCV maximum damper position potentiometers with compressor staging relay.
 - 2) Functions with solid-state analog enthalpy or dry bulb changeover control sensing.
 - 3) LED indicators for: when free cooling is available, when module is in DCV mode, when exhaust fan contact is closed.
- h. Economizer controller on EconoMi\$er X models shall be the Honeywell W7220 that provides:
 - 1) 2-line LCD interface screen for setup, configuration and troubleshooting.
 - 2) On-board Fault Detection and Diagnostics (FDD) that senses and alerts when the economizer is not operating properly, per California Title 24, ASHRAE 90.1 and IECC.
 - 3) Sensor failure loss of communication identification.
 - 4) Automatic sensor detection.
 - 5) Capabilities for use with multiple-speed or single speed indoor fan systems.
 - 6) Utilize digital sensors: Dry bulb and Enthalpy.
- i. Shall be capable of introducing up to 100% outdoor air.

Guide specifications (cont)

- j. Shall be equipped with a barometric relief damper capable of relieving up to 100% return air and contain seals that meet ASHRAE 90.1 requirements.
 - k. Shall be designed to close damper(s) during loss-of-power situations with spring return built into motor.
 - l. Dry bulb outdoor air temperature sensor shall be provided as standard. Enthalpy sensor is also available on factory installed only. Outdoor air sensor setpoint shall be adjustable and shall range from 40°F to 100°F (4°C to 38°C). Additional sensor options shall be available as accessories.
 - m. The economizer controller shall also provide control of an accessory power exhaust unit function. Factory set at 100%, with a range of 0% to 100%.
 - n. The economizer shall maintain minimum airflow into the building during occupied period and provide design ventilation rate for full occupancy.
 - o. Dampers shall be completely closed when the unit is in the unoccupied mode.
 - p. Economizer controller shall accept a 2 to 10 vdc CO₂ sensor input for IAQ/DCV control. In this mode, dampers shall modulate the outdoor air damper to provide ventilation based on the sensor input.
 - q. Compressor lockout temperature on W7220 control is adjustable from -45°F to 80°F (-43°C to 27°C), set at a factory default of 32°F (0°C). W7212 control opens at 35°F (2°C) and closes at 50°F (10°C).
 - r. Actuator shall be direct coupled to economizer gear. No linkage arms or control rods shall be acceptable.
 - s. Economizer controller shall provide indications when in free cooling mode, in the DCV mode, or the exhaust fan contact is closed.
2. Integrated EconoMi\$er X Ultra Low Leak rate models.
- a. Integrated, gear driven opposing modulating blade design type capable of simultaneous economizer and compressor operation.
 - b. Independent modules for vertical or horizontal return configuration shall be available. Vertical return modules shall be available as a factory-installed option.
 - c. Damper blades shall be galvanized steel with composite gears. Plastic or composite blades on intake or return shall not be acceptable.
 - d. Shall include all hardware and controls to provide free cooling with outdoor air when temperature and/or humidity are below setpoints.
 - e. Shall be equipped with gear driven dampers for both the outdoor ventilation air and the return air for positive air stream control.
 - f. Ultra Low Leak design meets California Title 24 section 140.4 and ASHRAE 90.1 requirements for 4 cfm per sq ft on the outside air dampers and 10 cfm per sq ft on the return dampers.
 - g. Economizer controller on EconoMi\$er X models shall be the Honeywell W7220 that provides:
 - 1) 2-line LCD interface screen for setup, configuration and troubleshooting.
 - 2) On-board Fault Detection and Diagnostics (FDD) that senses and alerts when the economizer is not operating properly, per California Title 24, ASHRAE 90.1 and IECC.
 - 3) Sensor failure loss of communication identification.
 - 4) Automatic sensor detection.
 - 5) Capabilities for use with multiple-speed indoor fan systems.
 - 6) Utilize digital sensors: Dry bulb and Enthalpy.
 - h. Shall be capable of introducing up to 100% outdoor air.
 - i. Shall be equipped with a barometric relief damper capable of relieving up to 100% return air and contain seals that meet ASHRAE 90.1 requirements.
 - j. Shall be designed to close damper(s) during loss-of-power situations with spring return built into motor.
 - k. Dry bulb outdoor air temperature sensor shall be provided as standard. Enthalpy sensor is also available on factory installed only. Outdoor air sensor setpoint shall be adjustable and shall range from 40°F to 100°F (4°C to 38°C). Additional sensor options shall be available as accessories.
 - l. The economizer controller shall also provide control of an accessory power exhaust unit function. Factory set at 100%, with a range of 0% to 100%.
 - m. The economizer shall maintain minimum airflow into the building during occupied period and provide design ventilation rate for full occupancy.
 - n. Dampers shall be completely closed when the unit is in the unoccupied mode.
 - o. Economizer controller shall accept a 2 to 10 vdc CO₂ sensor input for IAQ/DCV control. In this mode, dampers shall modulate the outdoor air damper to provide ventilation based on the sensor input.

Guide specifications (cont)

- p. Compressor lockout temperature on W7220 control is adjustable from -45°F to 80°F (-43°C to 27°C), set at a factory default of 32°F (0°C). W7212 control opens at 35°F (2°C) and closes at 50°F (10°C).
 - q. Actuator shall be direct coupled to economizer gear. No linkage arms or control rods shall be acceptable.
 - r. Economizer controller shall provide indications when in free cooling mode, in the DCV mode, or the exhaust fan contact is closed.
3. Two-Position Damper (field-installed only):
- a. Damper shall be a Two-Position Damper. Damper travel shall be from the full closed position to the field adjustable %-open setpoint.
 - b. Damper shall include adjustable damper travel from 25% to 100% (full open).
 - c. Damper shall include single or dual blade, gear driven dampers and actuator motor.
 - d. Actuator shall be direct coupled to damper gear. No linkage arms or control rods shall be acceptable.
 - e. Damper will admit up to 100% outdoor air for applicable rooftop units.
 - f. Damper shall close upon indoor (evaporator) fan shutoff and/or loss of power.
 - g. The damper actuator shall plug into the rooftop unit's wiring harness plug. No hard wiring shall be required.
 - h. Outside air hood shall include aluminum water entrainment filter.
4. Manual damper (field-installed only):
- a. Manual damper package shall consist of damper, air inlet screen, and rain hood which can be preset to admit up to 25% or 50% outdoor air for year round ventilation.
5. Low Ambient Control Package:
- a. Controller shall control coil head pressure by condenser fan speed modulation or condenser fan cycling and wind baffles.
 - b. Shall consist of solid-state control and condenser coil temperature sensor to maintain condensing temperature between 90°F (32°C) and 110°F (43°C) at outdoor ambient temperatures down to 0°F (-18°C).
6. Condenser Coil Hail Guard Assembly:
- a. Shall protect against damage from hail.
 - b. Shall be either hood style or louvered.
7. Unit-Mounted, Non-Fused Disconnect Switch (Available on 7.5 to 10 ton units with MOCPs of 80 amps or less, or 12.5 ton units with MOCPs of 100 amps or less):
- a. Switch shall be factory installed, internally mounted.
- b. National Electric Code (NEC) and UL approved non-fused switch shall provide unit power shutoff.
 - c. Shall be accessible from outside the unit.
 - d. Shall provide local shutdown and lockout capability.
 - e. Sized only for the unit as ordered from the factory. Does not accommodate field-installed devices.
8. Convenience Outlet:
- a. Powered convenience outlet.
 - 1) Outlet shall be powered from main line power to the rooftop unit.
 - 2) Outlet shall be powered from line side or load side of disconnect by installing contractor, as required by code. If outlet is powered from load side of disconnect, unit electrical ratings shall be UL certified and rated for additional outlet amperage.
 - 3) Outlet shall be factory-installed and internally mounted with easily accessible 115-v female receptacle.
 - 4) Outlet shall include 15 amp GFI receptacles with independent fuse protection.
 - 5) Voltage required to operate convenience outlet shall be provided by a factory installed step-down transformer.
 - 6) Outlet shall be accessible from outside the unit.
 - 7) Outlet shall include a field installed "Wet in Use" cover.
 - b. Factory-Installed Non-Powered convenience outlet.
 - 1) Outlet shall be powered from a separate 115/120v power source.
 - 2) A transformer shall not be included.
 - 3) Outlet shall be factory-installed and internally mounted with easily accessible 115-v female receptacle.
 - 4) Outlet shall include 15 amp GFI receptacles with independent fuse protection.
 - 5) Outlet shall be accessible from outside the unit.
 - 6) Outlet shall include a field installed "Wet in Use" cover.
 - c. Field-Installed Non-Powered convenience outlet.
 - 1) Outlet shall be powered from a separate 115/120v power source.
 - 2) A transformer shall not be included.
 - 3) Outlet shall be field-installed and internally mounted with easily accessible 115-v female receptacle.
 - 4) Outlet shall include 20 amp GFI receptacles. This kit provides a flexible

Guide specifications (cont)

- installation method which allows code compliance for height requirements of the GFCI outlet from the finished roof surface as well as the capability to relocate the outlet to a more convenient location.
- 5) Outlet shall be accessible from outside the unit.
 - 6) Outlet shall include a field installed "Wet in Use" cover.
9. Thru-the-Base Connectors:
 - a. Kits shall provide connectors to permit gas and electrical connections to be brought to the unit through the unit basepan.
 - b. Minimum of 4 connection locations per unit.
 10. Propeller Power Exhaust:
 - a. Power exhaust shall be used in conjunction with an integrated economizer.
 - b. Independent modules for vertical or horizontal return configurations shall be available.
 - c. Horizontal power exhaust is shall be mounted in return ductwork.
 - d. Power exhaust shall be controlled by economizer controller operation. Exhaust fans shall be energized when dampers open past the 0 to 100% adjustable setpoint on the economizer control.
 11. Supply Duct Cover (size 150 only):
 - a. Required when converting the factory standard vertical duct supply to horizontal duct supply configuration. One required per unit.
 12. Roof Curbs (Vertical):
 - a. Full perimeter roof curb with exhaust capability providing separate air streams for energy recovery from the exhaust air without supply air contamination.
 - b. Formed galvanized steel with wood nailer strip and shall be capable of supporting entire unit weight.
 - c. Permits installation and securing of ductwork to curb prior to mounting unit on the curb.
 13. Outdoor Air Enthalpy Sensor:
 - a. The outdoor air enthalpy sensor shall be used to provide single enthalpy control. When used in conjunction with a return air enthalpy sensor, the unit will provide differential enthalpy control. The sensor allows the unit to determine if outside air is suitable for free cooling.
 14. Return Air Enthalpy Sensor:
 - a. The return air enthalpy sensor shall be used in conjunction with an outdoor air enthalpy sensor to provide differential enthalpy control.
 15. Indoor Air Quality (CO₂) Sensor:
 - a. Shall be able to provide demand ventilation indoor air quality (IAQ) control.
 - b. The IAQ sensor shall be available in duct mount, wall mount, or wall mount with LED display. The setpoint shall have adjustment capability.
 16. Smoke detectors (factory-installed only):
 - a. Shall be a 4-wire controller and detector.
 - b. Shall be environmental compensated with differential sensing for reliable, stable, and drift-free sensitivity.
 - c. Shall use magnet-activated test/reset sensor switches.
 - d. Shall have tool-less connection terminal access.
 - e. Shall have a recessed momentary switch for testing and resetting the detector.
 - f. Controller shall include:
 - 1) One set of normally open alarm initiation contacts for connection to an initiating device circuit on a fire alarm control panel.
 - 2) Two Form-C auxiliary alarm relays for interface with rooftop unit or other equipment.
 - 3) One Form-C supervision (trouble) relay to control the operation of the Trouble LED on a remote test/reset station.
 - 4) Capable of direct connection to 2 individual detector modules.
 - 5) Can be wired to up to 14 other duct smoke detectors for multiple fan shut-down applications.
 17. Winter Start Kit:
 - a. Shall contain a bypass device around the low pressure switch.
 - b. Shall be required when mechanical cooling is required down to 25°F (-4°C).
 - c. Shall not be required to operate on an economizer when below an outdoor ambient of 40°F (4°C).
 18. Time Guard Control Circuit:
 - a. Shall prevent compressor short-cycling by providing a 5 minute delay (±2 minutes) before restarting a compressor after shut-down for any reason.
 - b. One device shall be required per compressor.
 19. Hinged Access Panels:
 - a. Shall provide easy access through integrated quarter turn latches.
 - b. Shall be on major panels of: filter, control box, fan motor, and compressor.

Guide specifications (cont)

20. Condensate overflow switch:

- a. This sensor and related controller monitors the condensate level in the drain pan and shuts down compression operation when overflow conditions occur. It includes:
 - 1) Indicator light — solid red (more than 10 seconds on water contact — compressors disabled), blinking red (sensor disconnected).
 - 2) 10 second delay to break — eliminates nuisance trips from splashing or waves in pan (sensor needs 10 seconds of constant water contact before tripping).
 - 3) Disables the compressors operation when condensate plug is detected, but still allows fans to run for Economizer.

21. 4 in. filter rack kit:

- a. The 4 in. filter rack accessory kit is designed to hold 4 in. MERV-8 or MERV-13 filters. Filters not included in kit.

22. Phase Monitor Control:

- a. Shall monitor the sequence of 3 phase electrical system to provide a phase reversal protection.
- b. Shall monitor the 3 phase voltage inputs to provide a phase loss protection for the 3 phase device.
- c. Will work on either a Delta or Wye power connection.

23. Horn/Strobe Annunciator:

- a. Provides an audible/visual signaling device for use with factory-installed option

or field installed accessory smoke detectors.

- 1) Requires installation of a field-supplied 24-v transformer suitable for 4.2 VA (AC) or 3.0 VA (DC) per horn/strobe accessory.
- 2) Requires field-supplied electrical box, North American 1-gang box, 2 in. (51 mm) x 4 in. (102 mm).
- 3) Shall have a clear colored lens.

24. Electric Heat:

a. Heating Section:

- 1) Heater element open coil resistance wire, nickel-chrome alloy, 0.29 inches inside diameter, strung through ceramic insulators mounted on metal frame. Coil ends are staked and welded to terminal screw slots.
- 2) Heater assemblies are provided with integral fusing for protection of internal heater circuits not exceeding 48 amps each. Auto reset thermo limit controls, magnetic heater contactors (24 v coil) and terminal block all mounted in electric heater control box (minimum 18 ga galvanized steel) attached to end of heater assembly.

25. UV-C ultraviolet lamp kit:

a. High-output, low temperature ultraviolet lamp accessory. It includes:

- 1) 36 in. lamp, interlock switch, mounting brackets, necessary wires, wire ties, screws and labels to field install kit in unit return air plenum.
- 2) Separate dedicated 115v power source required.