

Type R122H First-Stage Regulator

Introduction

The Type R122H is an Underwriters Laboratories listed regulator designed for Two-Stage LP-Gas systems. The unit is designed to reduce the tank pressure to an outlet pressure of 10 psig. The compact size makes it ideal for small domestic applications and underground tanks. The outlet pressure setting is nonadjustable and is factory set at a nominal 10 psig. Screened drip-lip vents are oriented over the outlet as standard.

Features

- **20 Year Recommended Replacement Life** – The R122H is designed using rugged time proven design concepts and constructed of corrosion resistant materials, both internally and externally. With proper installation and periodic inspection and maintenance the R122H regulator will meet a 20 Year Recommended Replacement Life.
- **Dual Gauge Taps** – Built-in 1/8 inch NPT gauge taps orificed to a number 54 drill size on both the inlet and outlet side of the regulator allow for easy testing.
- **Durability** – A fluorocarbon valve disc is utilized to improve lockup performance in systems with contaminated gas.
- **Improved Regulation** – A large fabric-reinforced diaphragm and stabilizer clip deliver accurate and stable regulation.
- **Easy Installation** – The units compact size and easily accessible inlet and outlet wrench flats make installation easy even in the tightest installations.
- **Superior Overpressure Protection** – The combination of a high capacity relief valve and large vent provide overpressure protection that exceeds UL standards. When used in conjunction with a R622 or R652, the two-stage system will limit the downstream pressure from the second-stage to 2 psig even in a double failure situation.
- **Corrosion-Resistant** – Added corrosion resistance from an internal and external coating process for all castings prior to painting, stainless steel relief valve spring and retainer and a corrosion resistant relief valve seat.
- **Positive Draining Spring Case** – When installed properly with the spring case vent pointed down, the design allows moisture formed in the spring case to drain out limiting the problems with corrosion and freezing water in the spring case.

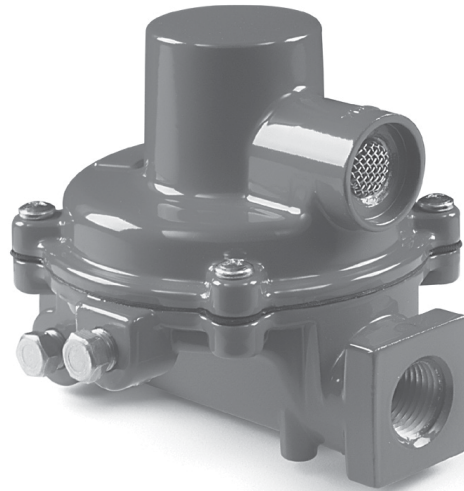
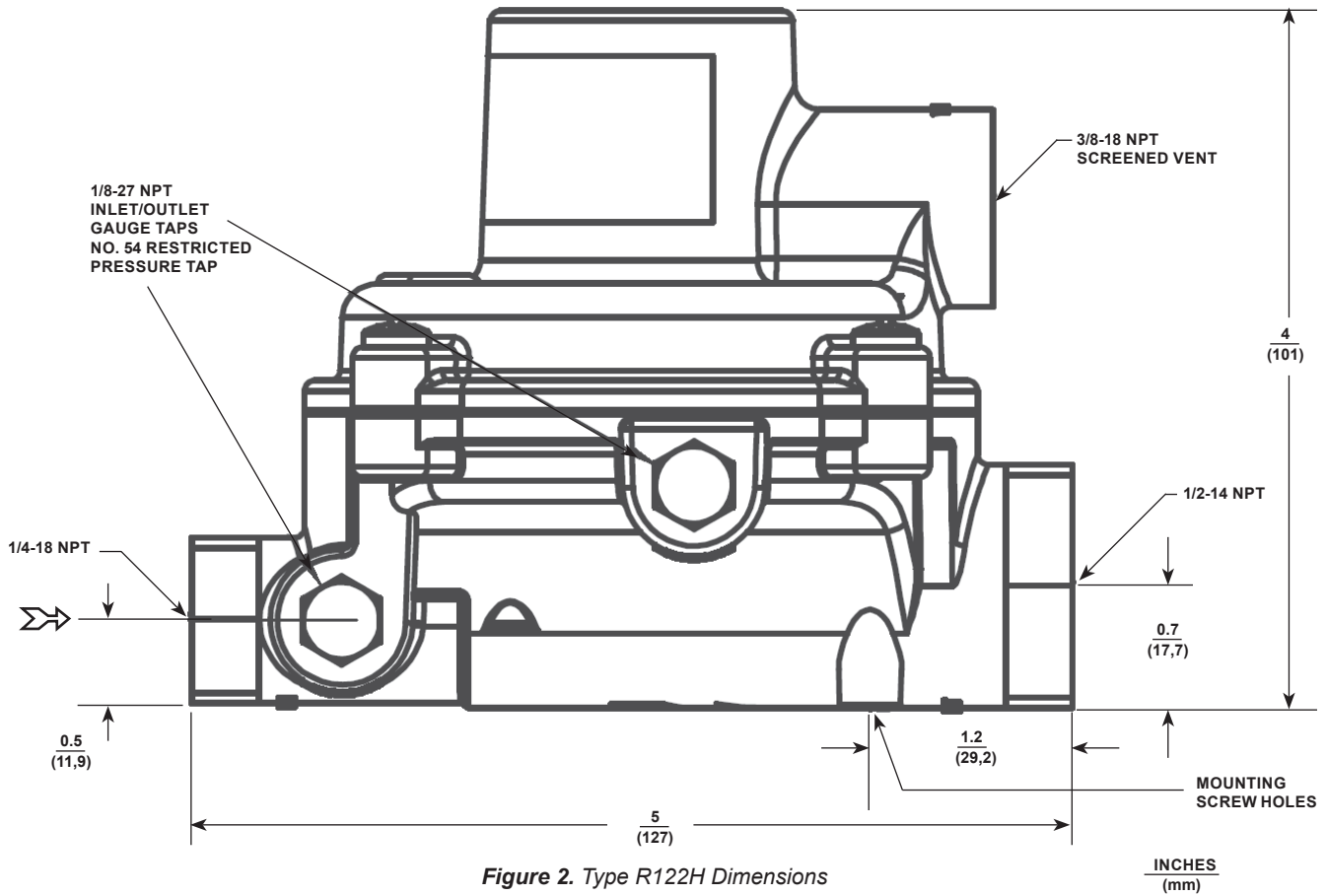

Figure 1. Type R122H First-Stage Regulator

Bulletin LP-7: R122H

Table 1. Ordering Information

TYPE NUMBER	CAPACITY BTU/HR PROPANE ⁽¹⁾	CONNECTIONS INLET x OUTLET	NOMINAL OUTLET SETTING
R122H-AAJ	1,100,000	1/4-inch x 1/2-inch NPT	10 psig (0,69 bar)
1. Capacity is based on 30 PSIG (2,07 bar) inlet pressure and 20% droop.			



LP-Gas Equipment

Emerson Process Management Regulator Technologies, Inc.

USA - Headquarters
 McKinney, Texas 75069-1872 USA
 Telephone: 1 (800) 558-5853
 Telephone: 1 (972) 548-3574

For further information visit www.fisherregulators.com/lp

The Emerson logo is a trademark and service mark of Emerson Electric Co. All other marks are the property of their prospective owners. Fisher is a mark owned by Fisher Controls, Inc., a business of Emerson Process Management.

The contents of this publication are presented for informational purposes only, and while every effort has been made to ensure their accuracy, they are not to be construed as warranties or guarantees, express or implied, regarding the products or services described herein or their use or applicability. We reserve the right to modify or improve the designs or specifications of such products at any time without notice.

Emerson Process Management does not assume responsibility for the selection, use or maintenance of any product. Responsibility for proper selection, use and maintenance of any Emerson Process Management product remains solely with the purchaser.