

**N4A3**  
**Performance Series Air Conditioner**  
**with R-410A Refrigerant**  
**1-1/2 To 5 Tons**



## Product Specifications



### Industry leading Features / Benefits

#### Efficiency

- 13.0 SEER / 11.0 EER (based on tested combination)

#### Reliability

- Non-ozone depleting R-410A refrigerant
- Scroll compressor
- Internal pressure relief valve
- Internal thermal overload
- Filter drier

#### Durability

- Solid, durable sheet metal construction
- Dense wire coil guard

#### Applications

- Long-line – up to 250 feet (76.20 m) total equivalent length, up to 200 feet (60.96 m) condenser above evaporator, or up to 80 ft. (24.38 m) evaporator above condenser (See Longline Guide for more information.)
- Low ambient (down to 0°F/-17.8°C) with accessory kit

#### Limited Warranty\*

- Default 5-year parts limited warranty (including compressor and coil)
  - 10-year parts limited warranty (including compressor and coil) with timely registration\*.Equipment must be registered within 90 days of original installation, except in jurisdictions where warranty benefits cannot be conditioned on registration.

\* Applies to original purchaser/homeowner and not available to subsequent owners, except in jurisdictions where laws dictate otherwise.

**See warranty certificate for complete details and restrictions, including warranty coverage for other applications**

N	4	A	3	18	A	H	B	1	0	0
<b>Product Family</b> N=Entry	<b>Refrigerant</b> 4 = R-410A	<b>Type</b> A = Air Conditioner	<b>Nominal Efficiency</b> 3 = 13 SEER	<b>Nominal Capacity</b> 18 = 1-1/2 Tons 24 = 2 Tons 30 = 2-1/2 Tons 36 = 3 Tons 42 = 3-1/2 Tons 48 = 4 Tons 60 = 5 Tons	<b>Variations</b> A = Standard Grille (Copper Tube Coil) G = Dense Grille (Copper Tube Coil) B = Standard Grille (Aluminum Tube Coil) L = Dense Grill (Aluminum Tube Coil)	<b>Electrical Supply</b> K = 208-230-1 or 208/230-1 H = 208/230-3 or 208/230-3 L = 460-3 S = 575-3	<b>Sales Code</b>	<b>Engineering Revision</b>	<b>Extra Digit</b>	<b>Extra Digit</b>



Use of the AHRI Certified Mark indicates a manufacturer's participation in the program. For verification of certification for individual products, go to www.ahridirectory.org.



Quality ISO 9001  
SAI GLOBAL



### CATALOG ORDERING NUMBERS

Phase	Size	Copper Coil Models	Aluminum Coil Models
Single Phase	18	N4A318(A,G)KF	N4A318(B,L)KA
	24	N4A324(A,G)KG	N4A324(B,L)KA
	30	N4A330(A,G)KG	N4A330(B,L)KA
	36	N4A336(A,G)KF	N4A336(B,L)KA
	42	N4A342(A,G)KN	N4A342(B,L)KA
	48	N4A348(A,G)KG	N4A348(B,L)KA
	60	N4A360(A,G)KN	N4A360(B,L)KA
Three Phase	30	N4A330GHC	N/A
	36	N4A336G(H,L,S)B	N/A
	42	N4A342G(H,L)A	N/A
	48	N4A348G(H,L,S)B	N/A
	60	N4A360G(H,L,S)C	N/A

### STANDARD FEATURES

Features	18	24	30	36	42	48	60
R-410A Refrigerant	X	X	X	X	X	X	X
SEER (Range depending on indoor combination)	13 - 15	13 - 15	13 - 15	13 - 15	13 - 14.5	13 - 15	13 - 14
Scroll Compressor	X	X	X	X	X	X	X
Field Installed Filter Drier	X	X	X	X	X	X	X
Front Seating Service Valves	X	X	X	X	X	X	X
Internal Pressure Relief Valve	X	X	X	X	X	X	X
Internal Thermal Overload	X	X	X	X	X	X	X
Long Line capability	X	X	X	X	X	X	X
Low Ambient capability with Kit	X	X	X	X	X	X	X

X = Standard

**PHYSICAL DATA 1-Phase (Copper Coil Models)**

UNIT SIZE	18(A,G)KF	24(A,G)KG	30(A,G)KG	36(A,G)KF	42(A,G)KN	48(A,G)KG	60(A,G)KN
<b>Compressor Type</b>	Scroll						
<b>REFRIGERANT</b>	R-410A						
Control	TXV (R-410a Hard Shutoff)						
Factory Charge lb (kg)	3.15 (1.4)	3.15 (1.43)	4.30 (1.95)	4.67 (2.12)	6.07 (2.75)	7.10 (3.22)	8.80 (4.0)
Required Charge* lb (kg)	4.20 (1.91)	4.17 (1.89)	4.90 (2.22)	5.36 (2.48)	--	8.20 (3.72)	--
<b>COND FAN</b>	Propeller Type, Direct Drive						
Air Discharge	Vertical						
Air Qty (CFM)	1792	2218	2163	3310	3167	3365	3365
Motor HP	1/12	1/10	1/10	1/5	1/5	1/4	1/4
Motor RPM	1100	1100	1100	1100	1100	1100	800
<b>COND COIL</b>							
Face Area (Sq ft)	8.40	8.40	11.49	12.93	17.25	19.40	12.93
Fins per In.	20	25	25	20	25	25	20
Rows	1	1	1	1	1	1	2
Circuits	3	3	3	5	4	5	5
<b>VALVE CONNECT. (In. ID)</b>							
Vapor	3/4	3/4	3/4	7/8	7/8	7/8	7/8
Liquid	3/8	3/8	3/8	3/8	3/8	3/8	3/8
<b>REFRIGERANT TUBES* (In. OD)</b>							
Rated Vapor†	3/4			7/8			1-1/8
Max Liquid Line‡	3/8						

\*.For 15 ft. lineset

†.Units are rated with 25 ft (7.6 m) of lineset length. See Vapor Line Sizing and Cooling Capacity Loss table when using other sizes and lengths of lineset.

‡.See Liquid Line Sizing For Cooling Only Systems with R-410A Refrigerant tables.

**PHYSICAL DATA 3-Phase (Copper Coil Models)**

UNIT SIZE	30GHC	36GHB	36GLB	36GSB	42GHA	42GLA	48GHB	48GLB	48GSB	60GHC	60GLC	60GSC
<b>Compressor Type</b>	Scroll											
<b>REFRIGERANT</b>	R-410A											
Control	TXV R-410A Hard Shutoff											
Factory Charge lb (kg)	4.10 (1.9)	5.34 (2.4)	5.34 (2.4)	5.34 (2.4)	5.84 (2.65)	5.84 (2.65)	7.00 (3.2)	7.00 (3.2)	7.00 (3.2)	8.00 (3.6)	8.00 (3.6)	8.00 (3.6)
Required Charge* lb (kg)	4.90 (2.22)	--	--	--	--	--	8.20 (3.72)	8.20 (3.72)	8.20 (3.72)	--	--	--
<b>COND FAN</b>	Propeller Type, Direct Drive											
Air Discharge	Vertical											
Air Qty (CFM)	2218	2954	2954	2954	3167	3167	3365	3365	3365	3365	3365	3365
Motor HP	1/10	1/4	1/4	1/4	1/5	1/5	1/4	1/4	1/4	1/4	1/4	1/4
Motor RPM	1100	1100	1100	1100	1100	1100	1100	1100	1100	1100	1100	1100
<b>COND COIL</b>												
Face Area (Sq ft)	9.80	13.13	13.13	13.13	17.25	17.25	19.40	19.40	19.40	15.09	15.09	15.09
Fins per In.	25	25	25	25	25	25	25	25	25	20	20	20
Rows	1	1	1	1	1	1	1	1	1	2	2	2
Circuits	3	3	3	3	4	4	5	5	5	6	6	6
<b>VALVE CONNECT. (In. ID)</b>												
Vapor	3/4	7/8	7/8	7/8	7/8	7/8	7/8	7/8	7/8	7/8	7/8	7/8
Liquid	3/8	3/8	3/8	3/8	3/8	3/8	3/8	3/8	3/8	3/8	3/8	3/8
<b>REFRIGERANT TUBES* (In. OD)</b>												
Rated Vapor†	3/4	7/8	7/8	7/8	7/8	7/8	7/8	7/8	7/8	7/8	7/8	7/8
Max Liquid Line‡	3/8											

\*.For 15 ft. lineset

†.Units are rated with 25 ft (7.6 m) of lineset length. See Vapor Line Sizing and Cooling Capacity Loss table when using other sizes and lengths of lineset.

‡.See Liquid Line Sizing For Cooling Only Systems with R-410A Refrigerant tables.

**PHYSICAL DATA (Aluminum Coil Models)**

UNIT SIZE	18(B,L)KA	24(B,L)KA	30(B,L)KA	36(B,L)KA	42(B,L)KA	48(B,L)KA	60(B,L)KA
<b>Compressor Type</b>	Scroll						
<b>REFRIGERANT</b>							
Control	TXV (Hard Shutoff)						
Factory Charge lb (kg)	2.77 (1.26)	2.77 (1.26)	3.78 (1.71)	4.11 (1.86)	5.84 (2.65)	7.10 (3.22)	8.80 (3.99)
Required Charge* lb (kg)	4.13 (1.87)	4.32 (1.96)	5.42 (2.46)	5.87 (2.66)	7.02 (3.18)	7.57 (3.43)	9.31 (4.22)
<b>COND FAN</b>	Propeller Type, Direct Drive						
Air Discharge	Vertical						
Air Qty (CFM)	1825	2242	2250	3353	3454	3454	3700
Motor HP	1/12	1/10	1/10	1/5	1/4	1/4	1/4
Motor RPM	1100	1100	1100	1100	1100	1100	1100
<b>COND COIL</b>							
Face Area (Sq ft)	8.40	8.40	11.49	12.93	17.25	19.40	15.09
Fins per In.	20	25	25	25	25	25	20
Rows	1	1	1	1	1	1	2
Circuits	3	3	3	5	5	6	6
<b>VALVE CONNECT. (In. ID)</b>							
Vapor	3/4	3/4	3/4	7/8	7/8	7/8	7/8
Liquid	3/8						
<b>REFRIGERANT TUBES (In. OD)</b>							
Rated Vapor*	3/4	3/4	3/4	7/8	7/8	7/8	1-1/8
Max Liquid Line†	3/8						

\*.Units are rated with 25 ft (7.6 m) of lineset length. See Vapor Line Sizing and Cooling Capacity Loss table when using other sizes and lengths of lineset.

†.See *Liquid Line Sizing For Cooling Only Systems with R-410A Refrigerant* tables.

**OUTDOOR UNIT CONNECTED TO A FACTORY APPROVED INDOOR UNIT**

Check piston size shipped with indoor unit to see if it matches required indoor piston size. If it does not match, replace indoor piston with correct piston size in table below:

OUTDOOR UNIT SIZE - SERIES	FAN COIL	PISTON SIZE BY OUTDOOR MODEL
<b>18</b>	FEM4P*	49
<b>24</b>	FEM4P*	55
<b>30</b>	FEM4P*	61
<b>36</b>	FEM4P*	67
<b>36 (3-phase)</b>	FEM4P*	67
<b>42</b>	FEM4P*	73
<b>48</b>	FEM4P*	78
<b>48 (3-phase)</b>	FEM4P*	76

\* Ratings contained in this document are subject to change at any time. Always refer to the AHRI directory ([www.ahridirectory.org](http://www.ahridirectory.org)) for the most up-to-date ratings information.

**NOTE:** Pistons shipped with outdoor units are only qualified and approved with the above listed fan coils. The piston included with the FFMANP\* and FPMAN\* fan coils are unique to those products and CANNOT be replaced with the piston shipped with outdoor unit. Refer to the AHRI directory ([www.ahridirectory.org](http://www.ahridirectory.org)) to check if your combination can use a piston or requires an accessory TXV

## Liquid Line Sizing and Maximum Total Equivalent Lengths for Cooling Only Systems with R-410A Refrigerant:

The maximum allowable length of a residential split system depends on the liquid line diameter and vertical separation between indoor and outdoor units.

See table below for liquid line sizing and maximum lengths :

### Maximum Total Equivalent Length Outdoor Unit BELOW Indoor Unit

Size	Liquid Line Connection	Liquid Line Diam. w/ TXV	AC with R-410A Refrigerant Maximum Total Equivalent Length†: Outdoor unit BELOW Indoor Vertical Separation ft (m)								
			0-5 (0-1.5)	6-10 (1.8-3.0)	11-20 (3.4-6.1)	21-30 (6.4-9.1)	31-40 (9.4-12.2)	41-50 (12.5-15.2)	51-60 (15.5-18.3)	61-70 (18.6-21.3)	71-80 (21.6-24.4)
018	3/8	1/4	150	150	125	100	100	75	—	—	—
		5/16	250*	250*	250*	250*	250*	250*	250*	225*	150
		3/8	250*	250*	250*	250*	250*	250*	250*	250*	250*
024	3/8	1/4	75	75	75	50	50	--	--	--	--
		5/16	250*	250*	250*	250*	250*	225*	175	125	100
		3/8	250*	250*	250*	250*	250*	250*	250*	250*	250*
030	3/8	1/4	30	--	--	--	--	--	--	--	--
		5/16	175	225*	200	175	125	100	75	--	--
		3/8	250*	250*	250*	250*	250*	250*	250*	250*	250*
036	3/8	5/16	175	150	150	100	100	100	75	--	--
		3/8	250*	250*	250*	250*	250*	250*	250*	250*	250*
042	3/8	5/16	125	100	100	75	75	50	--	--	--
		3/8	250*	250*	250*	250*	250*	250*	250*	250*	150
048	3/8	3/8	250*	250*	250*	250*	250*	250*	230	160	--
060	3/8	3/8	250*	250*	250*	225*	190	150	110	--	--

\* Maximum actual length not to exceed 200 ft (61 m)

† Total equivalent length accounts for losses due to elbows or fitting. See the Long Line Guideline for details.

--"= outside acceptable range

### Maximum Total Equivalent Length Outdoor Unit ABOVE Indoor Unit

Size	Liquid Line Connection	Liquid Line Diam. w/ TXV	AC with R-410A Refrigerant Maximum Total Equivalent Length†: Outdoor unit ABOVE Indoor Vertical Separation ft (m)								
			25 (7.6)	26-50 (7.9-15.2)	51-75 (15.5-22.9)	76-100 (23.2-30.5)	101-125 (30.8-38.1)	126-150 (38.4-45.7)	151-175 (46.0-53.3)	176-200 (53.6-61.0)	
018	3/8	1/4	175	250*	250*	250*	250*	250*	250*	250*	250*
		5/16	250*	250*	250*	250*	250*	250*	250*	250*	250*
		3/8	250*	250*	250*	250*	250*	250*	250*	250*	250*
024	3/8	1/4	100	125	175	200	225*	250*	250*	250*	250*
		5/16	250*	250*	250*	250*	250*	250*	250*	250*	250*
		3/8	250*	250*	250*	250*	250*	250*	250*	250*	250*
030	3/8	1/4	30	--	--	--	--	--	--	--	--
		5/16	250*	250*	250*	250*	250*	250*	250*	250*	250*
		3/8	250*	250*	250*	250*	250*	250*	250*	250*	250*
036	3/8	5/16	225*	250*	250*	250*	250*	250*	250*	250*	250*
		3/8	250*	250*	250*	250*	250*	250*	250*	250*	250*
042	3/8	5/16	175	200	250*	250*	250*	250*	250*	250*	250*
		3/8	250*	250*	250*	250*	250*	250*	250*	250*	250*
048	3/8	3/8	250*	250*	250*	250*	250*	250*	250*	250*	250*
060	3/8	3/8	250*	250*	250*	250*	250*	250*	250*	250*	250*

\* Maximum actual length not to exceed 200 ft (61 m)

† Total equivalent length accounts for losses due to elbows or fitting. See the Long Line Guideline for details.

--"= outside acceptable range

**Refrigerant Charge Adjustments**

Liquid Line Size	R-410A Charge oz/ft (g/m)
3/8	0.60 (17.74) (Factory charge for lineset = 9 oz / 266.16 g)
5/16	0.40 (11.83)
1/4	0.27 (7.98)

Units are factory charged for 15 ft (4.6 m) of 3/8" liquid line\*. The factory charge for 3/8" lineset 9 oz. When using other length or diameter liquid lines, charge adjustments are required per the chart above.

**Charging Formula:**

$[(\text{Lineset oz/ft} \times \text{total length}) - (\text{factory charge for lineset})] = \text{charge adjustment}$

**Example 1:** System has 15 ft of line set\* using existing 1/4" liquid line. What charge adjustment is required?

Formula:  $(.27 \text{ oz/ft} \times 15\text{ft}) - (9 \text{ oz}) = (-4.95) \text{ oz.}$

Net result is to remove 4.95 oz of refrigerant from the system

**Example 2:** System has 45 ft of existing 5/16" liquid line. What is the charge adjustment?

Formula:  $(.40 \text{ oz/ft.} \times 45\text{ft}) - (9 \text{ oz.}) = 9 \text{ oz.}$

Net result is to add 9 oz of refrigerant to the system

**NOTE:** Conditions must be favorable for charging by subcooling method. Indoor temperature must be 70°F to 80°F (21.1°C to 26.7°C), and outdoor temperature must be 70°F to 100°F (21.1°C to 37.8°C). If outside these conditions, adjust charge for long line sets by weigh-in method.

\* When applicable. Refer to Physical Data Table in this PD and to the Installation Instructions for more information.

**LONG LINE APPLICATIONS**

An application is considered Long Line, when the refrigerant level in the system requires the use of accessories to maintain acceptable refrigerant management for systems reliability. See Accessory Usage Guideline table for required accessories. Defining a system as long line depends on the liquid line diameter, actual length of the tubing, and vertical separation between the indoor and outdoor units.

For Air Conditioner systems, the chart below shows when an application is considered Long Line.

**AC with R-410A Refrigerant Long Line Description ft (m) Beyond these lengths, a TXV is required**

Total Length	Outdoor Unit Above or Below Indoor Unit
TXV required beyond 50 ft. (15.2 m)	TXV required beyond 20 ft. (6.1 m)

**AC with R-410A Refrigerant Long Line Description ft (m) (Beyond these lengths, long line accessories are required)**

Liquid Line Size	Units On Same Level	Outdoor Below Indoor	Outdoor Above Indoor
1/4 + TXV	No accessories needed within allowed lengths	No accessories needed within allowed lengths	175 (53.3)
5/16 + TXV	120 (36.6)	50 (15.2) vertical or 120 (36.6) total	120 (36.6)
3/8 + TXV	80 (24.4)	35 (10.7) vertical or 80 (24.4) total	80 (24.4)

Note: See Residential Piping and Long Line Guideline for details

**VAPOR LINE SIZING AND COOLING CAPACITY LOSS**

Acceptable vapor line diameters provide adequate oil return to the compressor while avoiding excessive capacity loss. The suction line diameters shown in the chart below are acceptable for AC systems with R-410Arefrigerant:

**Vapor Line Sizing and Cooling Capacity Losses — 1-Stage Air Conditioner with R-410A Refrigerant Applications**

Unit Nominal Size (Btuh)	Maximum Liquid Line Diameters (In. OD)	Vapor Line Diameters (In. OD)	Cooling Capacity Loss (%)								
			Total Equivalent Line Length ft. (m)								
			26-50 (7.9-15.2)	51-80 (15.5-24.4)	81-100 (24.7-30.5)	101-125 (30.8-38.1)	126-150 (38.4-45.7)	151-175 (46.0-53.3)	176-200 (53.6-61.0)	201-225 (61.3-68.6)	226-250 (68.9-76.2)
018	3/8	1/2	1	2	3	5	6	7	8	9	11
		5/8	0	1	1	1	2	2	2	3	3
		3/4	0	0	0	0	1	1	1	1	1
024	3/8	5/8	0	1	2	2	3	3	4	5	5
		3/4	0	0	1	1	1	1	1	2	2
		7/8	0	0	0	0	0	1	1	1	1
030	3/8	5/8	1	2	3	3	4	5	6	7	8
		3/4	0	0	1	1	1	2	2	2	3
		7/8	0	0	0	0	1	1	1	1	1
036	3/8	5/8	1	2	4	5	6	8	9	10	12
		3/4	0	1	1	2	2	3	3	4	4
		7/8	0	0	0	1	1	1	1	2	2
042	3/8	3/4	0	1	2	2	3	4	4	5	6
		7/8	0	0	1	1	1	2	2	2	3
		1 1/8	0	0	0	0	0	0	0	0	0
048	3/8	3/4	0	1	2	3	4	5	5	6	7
		7/8	0	0	1	1	2	2	2	3	3
		1 1/8	0	0	0	0	0	0	0	1	1
060	3/8	3/4	1	2	4	5	6	7	9	10	11
		7/8	0	1	2	2	3	4	4	5	5
		1 1/8	0	0	0	1	1	1	1	1	1

Applications in this area may be long line and may have height restrictions. See the Residential Piping and Long Line Guideline.

**ACCESSORIES (For Copper Coil Models)**

Part Number	Description	Used On Model Size
NASA003CH	Crankcase Heater for Scroll Compressor (208/230V)	18, 24, 30, 36
NASA001CH	Crankcase Heater for Scroll Compressor (208/230V)	42, 48, 60
NASA003SC	Hard Start Kit (Capacitor & Relay)	ALL
NASA00201FS	Evaporator Freeze Thermostat	ALL
NASA403PS	Low Pressure Switch, AC, R-410A	ALL
NASA404PS	High Pressure Switch, AC or HP, R-410A	ALL
NASA001LS*	Liquid Line Solenoid Valve, R-410A	ALL
NASA001TD	Time Delay Relay, Indoor Blower	ALL
NASA00201WS	Winter Start Control	ALL
NASA001AC	Anti-Cycle Timer (5 minute delay)	ALL
NASA401LA	Low Ambient Kit (Pressure Switch), R-410A	ALL
NASA00201SF	Support Feet, 4" (102mm) tall (5 blocks)	ALL
NASA00301SJ	Sound Jacket, Compressor	18, 24, 36
NASA00201SJ	Sound Jacket, Compressor	30
NASA00101SJ	Sound Jacket, Compressor	42, 48, 60
NAEA40501TX	TXV Kit, R-410A – for use with copper or tin fan coils	18, 24
NAEA40601TX	TXV Kit, R-410A – for use with copper or tin fan coils	30, 36, 42
NAEA40701TX	TXV Kit, R-410A – for use with copper or tin fan coils	48, 60
NAEB40501TX	TXV Kit, R-410A – for use with aluminum coils	18, 24
NAEB40601TX	TXV Kit, R-410A – for use with aluminum coils	30, 36, 42
NAEB40701TX	TXV Kit, R-410A – for use with aluminum coils	48, 60

**ACCESSORIES (for Aluminum Coil Models)**

KIT NUMBER	KIT NAME	Used on Model Size
NASA00201FS	FRZ THERM KIT	ALL
NASA001TD	TIME DELAY KIT	ALL
NASA401LA	LOW AMBIENT KIT	ALL
NASA012SC	HARD START KIT	18 - 48
NASA014SC	HARD START KIT	60
NASA001AC	CYCLE PROTR KIT	ALL
NASA00201SF	SPRT FEET KIT	ALL
NASA001SC	PTC KIT	ALL
NASA401LS*	SOL VALVE KIT	ALL
NASA00201WS	WINTER ST KIT	ALL
NASA403PS	PRESSURE SW KIT	ALL
NASA404PS	PRESSURE SW KIT	ALL
NASA00601CH	CRKC HTR KIT	18, 24, 30, 36
NASA00501CH	CRKC HTR KIT	42, 48, 60
NAEA40501TX	TXV KIT (for use with copper coils)	18, 24, 30
NAEA40601TX	TXV KIT (for use with copper coils)	36, 42
NAEA40701TX	TXV KIT (for use with copper coils)	48, 60
NAEB40501TX	TXV KIT (for use with aluminum coils)	18, 24, 30
NAEB40601TX	TXV KIT (for use with aluminum coils)	36, 42
NAEB40701TX	TXV KIT (for use with aluminum coils)	48, 60
NASA00201SJ	SOUND BLKT KIT	18, 24
NASA00301SJ	SOUND BLKT KIT	30, 36
NASA00101SJ	SOUND BLKT KIT	42, 48, 60

\* Do not use Hard Shutoff TXV with Liquid Solenoid Valve

## ACCESSORY USAGE GUIDELINE

ACCESSORY	REQUIRED FOR LOW-AMBIENT COOLING APPLICATIONS (Below 55°F/12.8°C)	REQUIRED FOR LONG LINE APPLICATIONS*	REQUIRED FOR SEA COAST APPLICATIONS (Within 2 miles/3.22 km)
Ball Bearing Fan Motor	Standard on single-phase models	Standard on single-phase models	Standard on single-phase models
Compressor Start Assist Capacitor and Relay	Yes	Yes	No
Crankcase Heater	Yes	Yes	No
Evaporator Freeze Thermostat	Yes	No	No
Hard Shut-Off TXV	Yes	Yes	Yes
Liquid Line Solenoid Valve	No	No	No
Low-ambient Pressure Switch	Yes	No	No
Support Feet	Recommended	No	Recommended
Winter Start Control	Yes #	No	No

\*For tubing set lengths between 80 and 200 ft. (24.38 and 60.96 m) horizontal or 35 ft. (10.7 m) vertical differential (total equivalent length), refer to the Residential Split-System Longline Application Guideline.

#Required if Low Pressure Switch is factory or field installed.

### Accessory Description and Usage (Listed Alphabetically)

#### 1. Ball-Bearing Fan Motor

A fan motor with ball bearings which permits speed reduction while maintaining bearing lubrication.

Usage Guideline:

Required on all units when MotorMaster® is used.

#### 2. Compressor Start Assist - Capacitor and Relay

Start capacitor and relay gives a "hard" boost to compressor motor at each start up.

Usage Guideline:

Required for reciprocating compressors in the following applications:

- Long line
- Low ambient cooling
- Hard shut off expansion valve on indoor coil
- Liquid line solenoid on indoor coil

Required for single-phase scroll compressors in the following applications:

- Long line
- Low ambient cooling

Suggested for all compressors in areas with a history of low voltage problems.

#### 3. Crankcase Heater

An electric resistance heater which mounts to the base of the compressor to keep the lubricant warm during off cycles. Improves compressor lubrication on restart and minimizes the chance of liquid slugging.

Usage Guideline:

- Required in low ambient cooling applications.
- Required in long line applications.
- Suggested in all commercial applications.

#### 4. Cycle Protector

The cycle protector is designed to prevent compressor short cycling. This control provides an approximate 5-minute delay after power to the compressor has been interrupted for any reason, including power outage, protector control trip, thermostat jiggling, or normal cycling.

#### 5. Evaporator Freeze Thermostat

An SPST temperature-actuated switch that stops unit operation when evaporator reaches freeze-up conditions.

Usage Guideline:

Required when low ambient kit has been added.

#### 6. Low-Ambient Pressure Switch Kit

A long life pressure switch which is mounted to outdoor unit service valve. It is designed to cycle the outdoor fan motor in order to maintain head pressure within normal operating limits (approximately 100 psig to 225 psig). The control will maintain working head pressure at low-ambient temperatures down to 0°F (-18°C) when properly installed.

Usage Guideline:

A Low-Ambient Pressure Switch must be used when cooling operation is used at outdoor temperatures below 55°F (12.8°C).

#### 7. Outdoor Air Temperature Sensor

This device enables the thermostat to display the outdoor temperature. This device is also required to enable special thermostat features such as auxiliary heat lock out.

Usage Guideline:

Suggested for use with compatible thermostats.

#### 8. Sound Hood

Wraparound sound reducing cover for the compressor. Reduces the sound level of the compressor.

Usage Guideline:

Suggested when unit is installed closer than 15 ft (4.57 m) to quiet areas, bedrooms, etc.

Suggested when unit is installed between two houses less than 10 ft (3.05 m) apart.

#### 9. Support Feet

Four or five stick-on plastic feet that raise the unit 4 in. (101.6 mm) above the mounting pad. This allows sand, dirt, and other debris to be flushed from the unit base, minimizing corrosion.

Usage Guideline:

Suggested in the following applications:

- Coastal installations.
- Windy areas or where debris is normally circulating.
- Rooftop installations.
- For improved sound ratings.



## Accessory Description and Usage (Listed Alphabetically) Continued

### 10. Thermostatic Expansion Valve (TXV)

A modulating flow-control valve which meters refrigerant liquid flow rate into the evaporator in response to the superheat of the refrigerant gas leaving the evaporator.

Kit includes valve, adapter tubes, and external equalizer tube. Hard shut off types are available.

**NOTE:** When using a hard shut off TXV with single phase reciprocating compressors, a Compressor Start Assist Capacitor and Relay is required.

Usage Guideline:

Required to achieve AHRI ratings in certain equipment combinations. Refer to combination ratings.

Hard shut off TXV or LLS required in air conditioner long line applications.

Required for use on all zoning systems.

### 11. Time-Delay Relay

An SPST delay relay which briefly continues operation of indoor blower motor to provide additional cooling after the compressor cycles off.

**NOTE:** Most indoor unit controls include this feature. For those that do not, use the guideline below.

Usage Guideline:

For improved efficiency ratings for certain combinations of indoor and outdoor units. Refer to AHRI Unitary Directory.

### 12. Winter Start Control

This control is designed to alleviate nuisance opening of the low-pressure switch by bypassing it for the first 3 minutes of operation.

## AHRI RATINGS

For AHRI ratings certificates, please refer to the AHRI directory [www.ahridirectory.org](http://www.ahridirectory.org)

Additional ratings and system combinations can be accessed via the Ratings Database here: [Heil Ratings](#)

## ELECTRICAL DATA

	UNIT SIZ	V/PH	OPER VOLTS*		COMPR		FAN	MCA	MAX FUSE** or CKT BRK AMPS
			MAX	MIN	LRA	RLA	FLA		
Copper Coil Models	18(A,G)KF	208/230/1	253	197	47.5	9.0	0.50	11.8	20
	24(A,G)KG				62.9	10.9	0.70	14.3	25
	30(A,G)KG				67.8	12.8	0.60	16.6	25
	36(A,G)KF				79.0	13.6	1.10	18.1	30
	42(A,G)KN				112.0	17.9	1.10	23.5	40
	48(A,G)KG				93.0	18.3	1.40	24.3	40
	60(A,G)KN				125.0	22.1	1.40	29.0	50
	30GHC	208/230-3	253	187	58.0	8.3	0.77	11.2	20
	36GHB				71.0	10.5	1.40	14.5	20
	42GHA				88.0	13.5	1.10	18.0	30
	48GHB				83.1	13.1	1.40	17.8	30
	60GHC				110.0	16.0	1.40	21.4	30
	36GLB	460-3	506	414	38.0	5.6	0.70	7.7	15
	42GLA				44.0	6.0	0.60	8.1	15
	48GLB				41.0	6.1	0.70	8.3	15
	60GLC				52.0	7.8	0.70	10.5	15
	36GSB	575-3	532	518	36.5	3.8	0.50	5.3	15
	48GSB				33.0	4.4	0.50	6.0	15
60GSC	38.9				5.7	0.50	7.6	15	
Aluminum Coil Models	18(B,L)KA	208/230/1	253	197	48.0	8.0	0.50	10.5	15
	24(B,L)KA				61.0	10.6	0.70	14.0	20
	30(B,L)KA				67.8	12.8	0.60	16.6	25
	36(B,L)KA				79.0	13.6	1.05	18.1	30
	42(B,L)KA				123.9	19.2	1.40	25.4	40
	48(B,L)KA				93.0	18.3	1.40	24.3	40
	60(B,L)KA				127.9	22.2	1.52	29.3	50

\* Permissible limits of the voltage range at which the unit will operate satisfactorily.

\*\* Time-Delay fuse.

Complies with 2007 requirements of ASHRAE Standards 90.1

**FLA** -Full Load Amps

**LRA** -Locked Rotor Amps

**MCA** - Minimum Circuit Amps

**RLA** -Rated Load Amps

**NOTE:** Control circuit is 24-V on all units and requires external power source. Copper wire must be used from service disconnect to unit.

All motors/compressors contain internal overload protection.

**A-WEIGHTED SOUND POWER (dBA)**

UNIT SIZE	STANDARD RATING	TYPICAL OCTAVE BAND SPECTRUM (without tone adjustment)						
		125	250	500	1000	2000	4000	8000
18	71	49.7	56.5	62.1	67.6	65.2	59.7	53.9
24	74	50.2	60.9	65.5	67.5	65.0	60.7	54.0
30	72	53.6	60.1	65.7	68.3	64.0	60.9	56.5
36	75	57.4	66.4	70.0	70.2	67.6	64.4	58.5
42	78	55.6	66.7	66.6	68.5	65.2	63.1	58.5
48	76	56.4	63.4	69.4	70.4	68.9	69.0	60.1
60	79	59.9	65.5	68.2	70.1	68.4	65.4	61.7

NOTE: Tested in compliance with AHRI 270–2008 (not listed with AHRI)

**A-WEIGHTED SOUND POWER (dBA) with SOUND SHIELD**

UNIT SIZE	STANDARD RATING	TYPICAL OCTAVE BAND SPECTRUM (without tone adjustment)						
		125	250	500	1000	2000	4000	8000
18	70	51.0	57.4	62.3	66.3	63.3	58.7	52.3
24	74	51.5	61.6	65.4	66.8	63.9	60.2	53.2
30	72	53.4	60.7	65.5	67.8	63.6	60.4	54.8
36	75	56.8	65.9	69.5	69.4	67.3	63.5	56.1
42	77	56.0	65.1	66.8	68.4	64.8	62.4	56.3
48	75	56.8	63.1	69.4	70.2	67.7	66.3	59.4
60	79	58.1	65.8	67.9	68.7	66.0	62.0	57.0

NOTE: Tested in compliance with AHRI 270–2008 (not listed with AHRI)

**CHARGING SUBCOOLING (TXV-TYPE EXPANSION DEVICE)**

UNIT SIZE	required subcooling (Copper Coil) °F (°C)	required subcooling (Aluminum Coil) °F (°C)	INDOOOR
18	14 (7.8)	14 (7.8)	TXV*
24	10 (5.6)	10 (5.6)	
30	10 (5.6)	11 (6.1)	
36	11 (6.1)	10 (5.6)	
36 (3-ph)	14 (7.8)	N/A	
42	10 (5.6)	10 (5.6)	
48	13 (7.2)	10 (5.6)	
48 (3-ph)	15 (8.3)	N/A	
60	15 (8.3)	16 (8.9)	
60 (3-ph)	10 (5.6)	N/A	

\*TXV must be ordered separately when indoor coil is not equipped with a TXV. TXV must be hard-shutoff type.

NOTE: Units are rated with 25 ft (7.6 m) of lineset length. See Vapor Line Sizing and Cooling Capacity Loss table when using other sizes and lengths of lineset.

# DIMENSIONS (Copper Coil Models)

UNIT	SERIES	ELECTRICAL CHARACTERISTICS				A		B		C		D		E		F		G		H		I		J		K		OPERATING WEIGHT		SHIPPING WEIGHT		SHIPPING LENGTH / WIDTH (Sq.)		SHIPPING HEIGHT	
						INCH	MM	INCH	MM	INCH	MM	INCH	MM	INCH	MM	INCH	MM	INCH	MM	INCH	MM	INCH	MM	INCH	MM	INCH	MM	INCH	MM	Lbs	Kgs	Lbs	Kgs	INCH	MM
N4A318*KF101	1	Y	N	N	N	23 1/8	587.3	25 5/16	642.9	3/4	19.1	4 7/16	113.0	18 1/16	459.0	7 13/16	197.9	5/16	7.9	3	76.2	16 1/2	419.1	15	381.0	12	304.8	107	48.5	120	54.4	26	660.0	30 9/16	775.7
N4A324*KG101	1	Y	N	N	N	23 1/8	587.3	25 5/16	642.9	3/4	19.1	4 7/16	113.0	18 1/16	459.0	7 13/16	197.9	5/16	7.9	3	76.2	12 1/2	317.5	11	279.4	12	304.8	107	48.5	120	54.4	26	660.0	30 9/16	775.7
N4A330*KG101	1	Y	N	N	N	25 3/4	654.0	28 11/16	728.7	3/4	19.1	4 7/16	113.0	21 1/4	539.9	9 1/8	231.3	5/16	7.9	3	76.2	14 1/2	368.3	15 1/2	393.7	12 1/2	317.5	126	57.2	140	63.5	28 3/4	730.0	33 15/16	862.1
N4A330GHC200	2	N	Y	N	N	23 1/8	587.3	28 11/16	729.3	3/4	19.1	4 7/16	113.0	18 1/16	459.0	7 13/16	197.9	5/16	7.9	3	76.2	16 1/2	419.1	15	381.0	14	355.6	111	50.3	124	56.2	26	660.0	33 15/16	862.1
N4A336*KF101	1	Y	N	N	N	31 3/16	792.5	25 5/16	642.4	7/8	22.2	6 9/16	166.1	24 11/16	626.3	9 1/8	231.3	5/16	7.9	3	76.2	15 9/16	395.3	16 1/2	419.1	10 1/4	260.4	134	60.8	150	68.0	34 1/4	870.0	30 1/2	775.2
N4A336G*B200	2	N	Y	Y	Y	25 3/4	654.0	32 1/16	815.1	7/8	22.2	4 7/16	113.0	21 1/4	539.9	9 1/8	231.3	5/16	7.9	3	76.2	14 1/4	362.0	10 1/2	266.7	16	406.4	141	64.0	155	70.3	28 3/4	730.0	37 5/16	948.4
N4A342*KN300	3	Y	N	N	N	31 3/16	792.5	32 1/16	815.1	7/8	22.2	6 9/16	166.1	24 11/16	626.3	9 1/8	231.3	5/16	7.9	3	76.2	15 3/4	400.1	16 1/4	412.8	13 3/4	349.3	180	81.6	197	89.4	34 1/4	870.0	37 5/16	947.9
N4A342G*A300	3	N	Y	Y	N	31 3/16	792.5	32 1/16	815.1	7/8	22.2	6 9/16	166.1	24 11/16	626.3	9 1/8	231.3	5/16	7.9	3	76.2	15 3/4	400.1	16 1/4	412.8	13 3/4	349.3	180	81.6	197	89.4	34 1/4	870.0	37 5/16	947.9
N4A348*KG101	1	Y	N	N	N	31 3/16	792.5	35 1/2	901.4	7/8	22.2	6 9/16	166.1	24 11/16	626.3	9 1/8	231.3	5/16	7.9	3	76.2	15 3/4	400.1	16 3/8	415.9	15 5/8	396.9	175	79.4	192	87.1	34 1/4	870.0	40 3/4	1034.3
N4A348G*B200	2	N	Y	Y	Y	31 3/16	792.5	35 1/2	901.4	7/8	22.2	6 9/16	166.1	24 11/16	626.3	9 1/8	231.3	5/16	7.9	3	76.2	14 3/4	374.7	15 3/8	390.5	15	381.0	186	84.4	203	92.1	34 1/4	870.0	40 3/4	1034.3
N4A360*KN400	4	Y	N	N	N	31 3/16	792.5	28 11/16	728.7	7/8	22.2	6 9/16	166.1	24 11/16	626.3	9 1/8	231.3	5/16	7.9	3	76.2	16	406.4	15 1/2	393.7	12 3/4	323.9	199	90.3	215	97.5	34 1/4	870.0	33 15/16	861.6
N4A360G*C300	3	N	Y	Y	Y	31 3/16	792.5	28 11/16	728.7	7/8	22.2	6 9/16	166.1	24 11/16	626.3	9 1/8	231.3	5/16	7.9	3	76.2	16	406.4	15 1/2	393.7	12 3/4	323.9	198	89.8	214	97.1	34 1/4	870.0	33 15/16	861.6

208-230-1-60	Y=YES N=NO
208-230-3-60	
460-3-60	
575-3-60	

**NOTES:**

1. CENTER OF GRAVITY

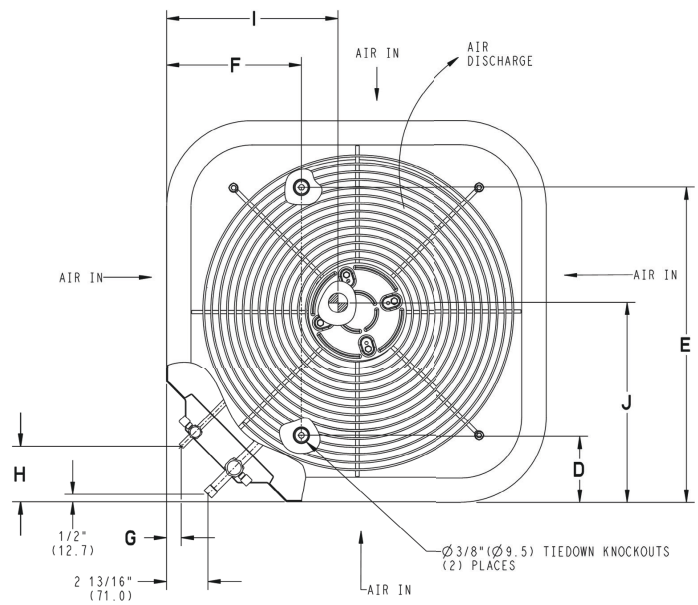
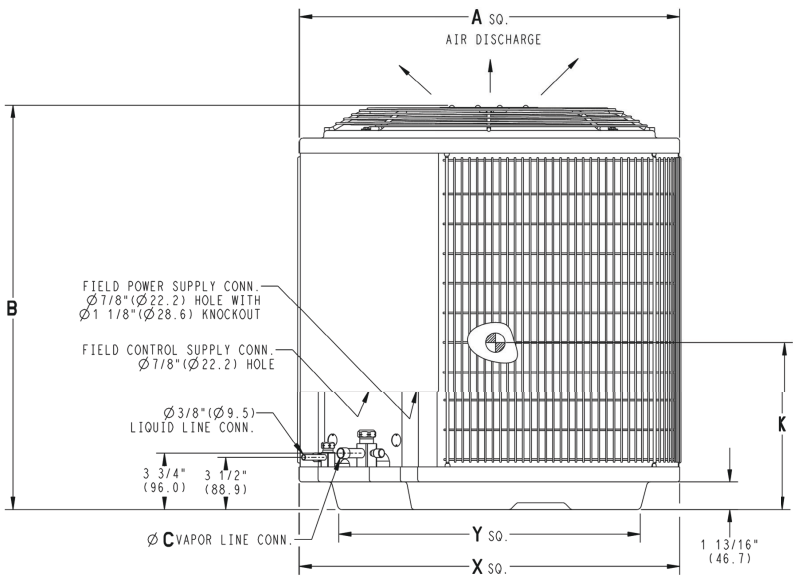

UNIT SIZE	"X"		"Y"	
	MINIMUM GROUND MOUNTING PAD APPLICATION DIMENSIONS		MINIMUM ROOF-TOP MOUNTING PAD APPLICATION DIMENSIONS	
18,24,30(3Ø)	23 1/8	587.3	17 7/8	454.6
30(1Ø),36(3Ø)	25 3/4	654.0	20 7/16	518.5
36(1Ø),42,48,60	31 3/16	792.5	22 15/16	583.2
-	35	889.0	26 3/4	679.7

NOTE: ALL DIMENSIONS IN INCH (MM)

U.S. ECCN: Not Subject to Regulation (N.S.R.)

Manufacturer reserves the right to change, at any time, specifications and designs without notice and without obligations.

# DIMENSIONS (Aluminum Coil Models)

UNIT	SERIES	ELECTRICAL CHARACTERISTICS				A		B		C		D		E		F		G		H		I		J		K		OPERATING WEIGHT		SHIPPING WEIGHT		SHIPPING LENGTH / WIDTH (Sq.)		SHIPPING HEIGHT	
		INCH	MM	INCH	MM	INCH	MM	INCH	MM	INCH	MM	INCH	MM	INCH	MM	INCH	MM	INCH	MM	INCH	MM	INCH	MM	INCH	MM	INCH	MM	Lbs	Kgs	Lbs	Kgs	INCH	MM	INCH	MM
N4A318BKA101	1	Y	N	N	N	23 1/8	587.3	25 5/16	642.9	3/4	19.1	4 7/16	113.0	18 1/16	459.0	7 13/16	197.9	5/16	7.9	3	76.2	11 3/4	298.5	12 1/2	317.5	12	304.8	98	44.5	111	50.3	26	660.0	30 9/16	775.7
N4A318LKA101	1	Y	N	N	N	23 1/8	587.3	25 5/16	642.9	3/4	19.1	4 7/16	113.0	18 1/16	459.0	7 13/16	197.9	5/16	7.9	3	76.2	11 3/4	298.5	12 1/2	317.5	12	304.8	98	44.5	111	50.3	26	660.0	30 9/16	775.7
N4A324BKA101	1	Y	N	N	N	23 1/8	587.3	25 5/16	642.9	3/4	19.1	4 7/16	113.0	18 1/16	459.0	7 13/16	197.9	5/16	7.9	3	76.2	12	304.8	12	304.8	11 1/2	292.1	100	45.1	112	50.8	26	660.0	30 9/16	775.7
N4A324LKA101	1	Y	N	N	N	23 1/8	587.3	25 5/16	642.9	3/4	19.1	4 7/16	113.0	18 1/16	459.0	7 13/16	197.9	5/16	7.9	3	76.2	12	304.8	12	304.8	11 1/2	292.1	100	45.1	112	50.8	26	660.0	30 9/16	775.7
N4A330BKA101	1	Y	N	N	N	25 3/4	654.0	28 11/16	728.7	3/4	19.1	4 7/16	113.0	21 1/4	539.9	9 1/8	231.3	5/16	7.9	3	76.2	13 3/4	349.3	12 1/2	317.5	13	330.2	114	51.5	128	58.1	28 3/4	730.0	33 15/16	862.1
N4A330LKA101	1	Y	N	N	N	25 3/4	654.0	28 11/16	728.7	3/4	19.1	4 7/16	113.0	21 1/4	539.9	9 1/8	231.3	5/16	7.9	3	76.2	13 3/4	349.3	12 1/2	317.5	13	330.2	114	51.5	128	58.1	28 3/4	730.0	33 15/16	862.1
N4A336BKA101	1	Y	N	N	N	31 3/16	792.5	25 5/16	642.4	7/8	22.2	6 9/16	166.1	24 11/16	626.3	9 1/8	231.3	5/16	7.9	3	76.2	14	355.6	14 1/2	368.3	11	279.4	128	58.1	147	66.5	34 1/4	870.0	30 1/2	775.2
N4A336LKA101	1	Y	N	N	N	31 3/16	792.5	25 5/16	642.4	7/8	22.2	6 9/16	166.1	24 11/16	626.3	9 1/8	231.3	5/16	7.9	3	76.2	14	355.6	14 1/2	368.3	11	279.4	128	58.1	147	66.5	34 1/4	870.0	30 1/2	775.2
N4A342BKA101	1	Y	N	N	N	31 3/16	792.5	32 1/16	815.1	7/8	22.2	6 9/16	166.1	24 11/16	626.3	9 1/8	231.3	5/16	7.9	3	76.2	14 3/4	374.7	17 3/4	450.9	15 1/2	393.7	170	77.1	194	88.2	34 1/4	870.0	37 5/16	947.9
N4A342LKA101	1	Y	N	N	N	31 3/16	792.5	32 1/16	815.1	7/8	22.2	6 9/16	166.1	24 11/16	626.3	9 1/8	231.3	5/16	7.9	3	76.2	14 3/4	374.7	17 3/4	450.9	15 1/2	393.7	170	77.1	194	88.2	34 1/4	870.0	37 5/16	947.9
N4A348BKA101	1	Y	N	N	N	31 3/16	792.5	35 1/2	901.4	7/8	22.2	6 9/16	166.1	24 11/16	626.3	9 1/8	231.3	5/16	7.9	3	76.2	15 3/4	400.1	14 3/4	374.7	17	431.8	165	74.6	186	84.4	34 1/4	870.0	40 3/4	1034.3
N4A348LKA101	1	Y	N	N	N	31 3/16	792.5	35 1/2	901.4	7/8	22.2	6 9/16	166.1	24 11/16	626.3	9 1/8	231.3	5/16	7.9	3	76.2	15 3/4	400.1	14 3/4	374.7	17	431.8	165	74.6	186	84.4	34 1/4	870.0	40 3/4	1034.3
N4A360BKA101	1	Y	N	N	N	31 3/16	792.5	28 11/16	728.7	7/8	22.2	6 9/16	166.1	24 11/16	626.3	9 1/8	231.3	5/16	7.9	3	76.2	15	381.0	15 1/4	387.4	13 1/2	342.9	183	83.1	202	91.8	34 1/4	870.0	33 15/16	861.6
N4A360LKA101	1	Y	N	N	N	31 3/16	792.5	28 11/16	728.7	7/8	22.2	6 9/16	166.1	24 11/16	626.3	9 1/8	231.3	5/16	7.9	3	76.2	15	381.0	15 1/4	387.4	13 1/2	342.9	183	83.1	202	91.8	34 1/4	870.0	33 15/16	861.6

20B-230-1-60
20B230-3-60
460-3-60
675-3-60

Y=YES  
N=NO

**NOTES:**

- CENTER OF GRAVITY

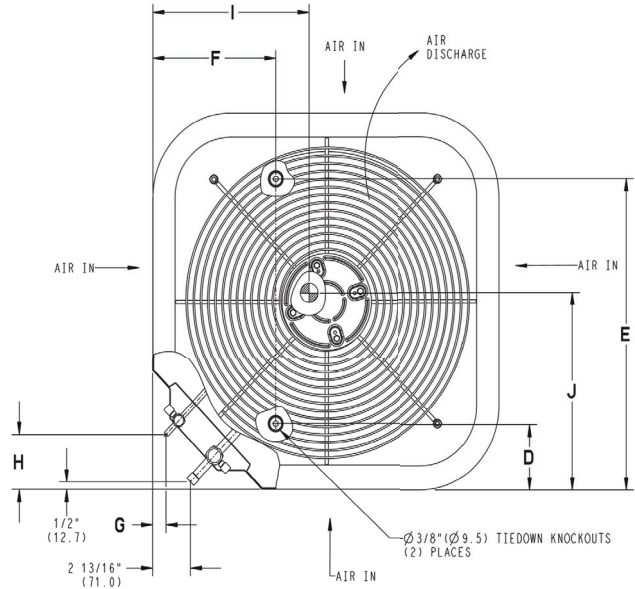
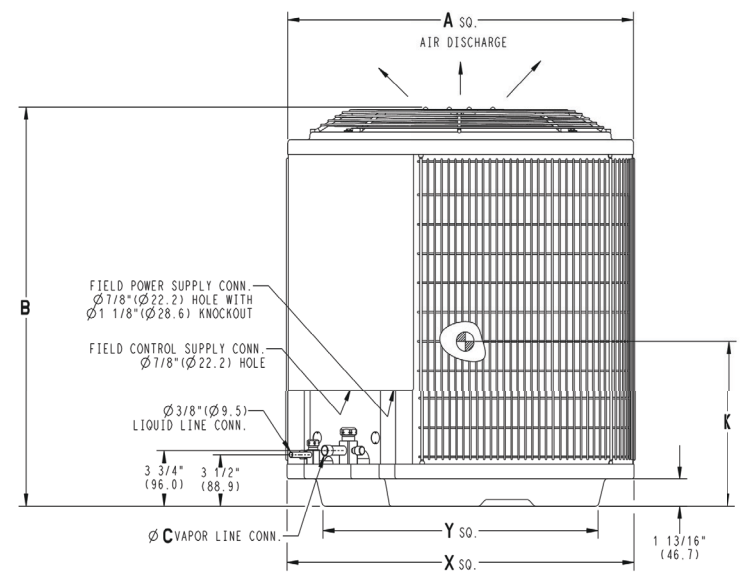

UNIT SIZE	"X" MINIMUM GROUND MOUNTING PAD APPLICATION DIMENSIONS		"Y" MINIMUM ROOF-TOP MOUNTING PAD APPLICATION DIMENSIONS	
	INCH	MM	INCH	MM
18,24	23 1/8	587.3	17 7/8	454.6
30	25 3/4	654.0	20 7/16	518.5
36,42,48,60	31 3/16	792.5	22 15/16	583.2
-	35	889.0	26 3/4	679.7

NOTE: ALL DIMENSIONS IN INCH (MM)

U.S. ECCN: Not Subject to Regulation (N.S.R.)

SD5587-4 REV. C

# Clearances

## Clearances (various examples)

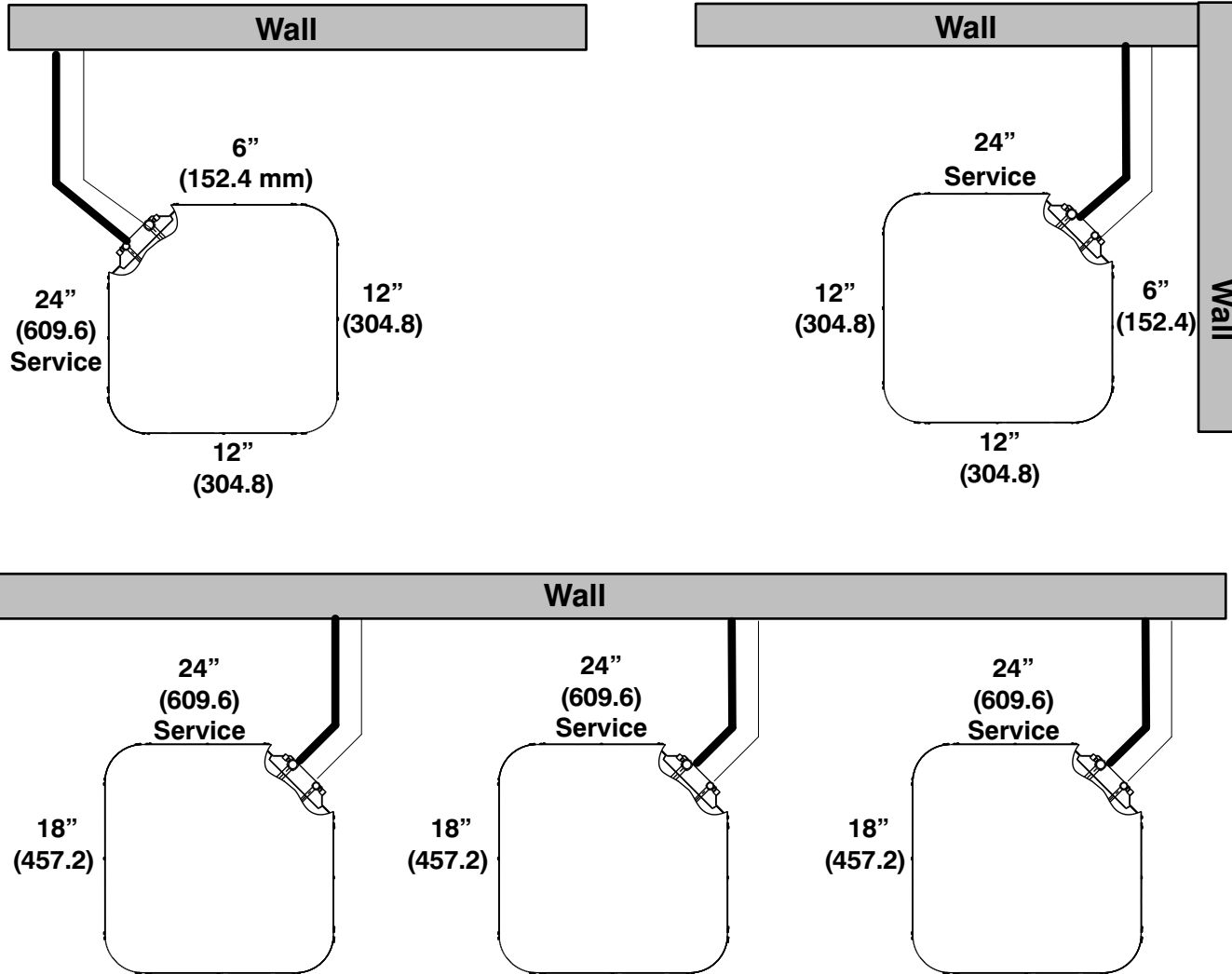

Note: Numbers in ( ) = mm  
Allow 48" above unit

**IMPORTANT:** When installing multiple units in an alcove, roof well, or partially enclosed area, ensure there is adequate ventilation to prevent re-circulation of discharge air.

### Detailed Cooling Capacities# - Copper Coil Models

EVAPORATOR AIR		CONDENSER ENTERING AIR TEMPERATURES °F (°C)														
		75 (23.9)		85 (29.4)		95 (35)		105 (40.6)		115 (46.1)						
CFM	EWB °F (°C)	Capacity MBtuh		Total Sys. KW**	Capacity MBtuh		Total Sys. KW**	Capacity MBtuh		Total Sys. KW**	Capacity MBtuh		Total Sys. KW**	Capacity MBtuh		Total Sys. KW**
		Total	Sens‡		Total	Sens‡		Total	Sens‡		Total	Sens‡		Total	Sens‡	
<b>N4A318(A,G)KF Outdoor Section With EN(A,D)4X24L14* Indoor Section</b>																
525	72 (22.2)	21.21	11.38	1.27	20.31	11.05	1.42	19.41	10.71	1.59	18.37	10.33	1.78	17.33	9.96	2.02
	67 (19.4)	19.33	14.06	1.28	18.52	13.73	1.43	17.62	13.36	1.60	16.64	12.96	1.79	15.65	12.56	2.02
	63 (17.2)††	18.04	16.20	1.29	17.23	15.83	1.44	16.39	15.44	1.60	15.49	15.02	1.79	14.60	14.56	2.02
	62 (16.7)	17.76	16.72	1.29	16.97	16.34	1.44	16.16	15.93	1.60	15.36	15.36	1.79	14.58	14.58	2.02
	57 (13.9)	17.47	17.47	1.30	16.77	16.77	1.44	16.08	16.08	1.60	15.34	15.34	1.79	14.56	14.56	2.02
600	72 (22.2)	21.47	11.95	1.30	20.62	11.65	1.45	19.68	11.30	1.62	18.64	10.93	1.81	17.55	10.55	2.05
	67 (19.4)	19.71	15.05	1.31	18.81	14.68	1.46	17.90	14.32	1.63	16.89	13.92	1.82	15.88	13.52	2.05
	63 (17.2)††	18.40	17.43	1.32	17.61	17.05	1.46	16.77	16.64	1.63	15.96	15.96	1.82	15.14	15.14	2.05
	62 (16.7)	18.19	18.01	1.32	17.54	17.28	1.46	16.74	16.74	1.63	15.96	15.96	1.82	15.14	15.14	2.05
	57 (13.9)	18.12	18.12	1.32	17.44	17.44	1.47	16.72	16.72	1.63	15.93	15.93	1.82	15.12	15.12	2.05
675	72 (22.2)	21.70	12.53	1.33	20.81	12.21	1.48	19.86	11.87	1.65	18.78	11.49	1.84	17.62	11.09	2.06
	67 (19.4)	19.88	15.95	1.34	19.03	15.61	1.49	18.11	15.24	1.66	17.08	14.83	1.85	16.07	14.43	2.08
	63 (17.2)††	18.79	18.56	1.35	18.02	18.02	1.49	17.27	17.27	1.66	16.44	16.44	1.85	15.60	15.60	2.08
	62 (16.7)	18.71	18.71	1.34	18.02	18.02	1.49	17.26	17.26	1.66	16.44	16.44	1.85	15.59	15.59	2.08
	57 (13.9)	18.70	18.70	1.34	18.00	18.00	1.49	17.24	17.24	1.66	16.41	16.41	1.85	15.57	15.57	2.08
<b>N4A324A,G)KG Outdoor Section With EN(A,D)4X24L14* Indoor Section</b>																
700	72 (22.2)	27.00	13.49	1.54	26.00	13.12	1.78	24.88	12.71	2.05	23.60	12.25	2.37	22.20	11.77	2.74
	67 (19.4)	24.70	16.72	1.54	23.76	16.33	1.78	22.68	15.90	2.05	21.51	15.44	2.37	20.23	14.95	2.74
	63 (17.2)††	23.00	16.10	1.55	22.07	15.69	1.78	21.07	15.26	2.06	19.97	14.80	2.37	18.77	14.30	2.75
	62 (16.7)	22.70	19.89	1.55	21.81	19.46	1.78	20.88	18.99	2.06	19.95	19.95	2.37	18.98	18.98	2.75
	57 (13.9)	22.29	22.29	1.55	21.58	21.58	1.78	20.79	20.79	2.06	19.92	19.92	2.37	18.96	18.96	2.75
800	72 (22.2)	27.39	14.17	1.57	26.35	13.79	1.81	25.20	13.38	2.09	23.87	12.92	2.41	22.42	12.43	2.78
	67 (19.4)	25.08	17.82	1.58	24.11	17.43	1.82	23.00	17.00	2.09	21.79	16.53	2.41	20.47	16.03	2.78
	63 (17.2)††	23.39	17.14	1.58	22.43	16.72	1.82	21.39	16.28	2.09	20.26	15.81	2.41	19.02	15.30	2.79
	62 (16.7)	23.24	21.32	1.58	22.43	22.43	1.82	21.59	21.59	2.09	20.66	20.66	2.41	19.62	19.62	2.79
	57 (13.9)	23.16	23.16	1.58	22.40	22.40	1.82	21.56	21.56	2.09	20.63	20.63	2.41	19.60	19.60	2.79
900	72 (22.2)	27.66	14.81	1.61	26.59	14.43	1.85	25.41	14.02	2.13	24.05	13.56	2.45	22.57	13.06	2.82
	67 (19.4)	25.36	18.88	1.61	24.37	18.49	1.85	23.24	18.05	2.13	22.00	17.57	2.45	20.65	17.05	2.82
	63 (17.2)††	23.67	18.11	1.62	22.70	17.70	1.85	21.63	17.25	2.13	20.47	16.77	2.45	19.21	16.24	2.83
	62 (16.7)	23.89	23.89	1.62	23.10	23.10	1.85	22.21	22.21	2.13	21.22	21.22	2.45	20.13	20.13	2.83
	57 (13.9)	23.86	23.86	1.62	23.07	23.07	1.85	22.18	22.18	2.13	21.20	21.20	2.45	20.11	20.11	2.83

### Detailed Cooling Capacities# - Copper Coil Models (Continued)

EVAPORATOR AIR		CONDENSER ENTERING AIR TEMPERATURES °F (°C)																	
		75 (23.9)		85 (29.4)				95 (35)				105 (40.6)				115 (46.1)			
		CFM	EWB °F (°C)	Capacity MBtuh		Total Sys. KW**	Capacity MBtuh		Total Sys. KW**	Capacity MBtuh		Total Sys. KW**	Capacity MBtuh		Total Sys. KW**	Capacity MBtuh		Total Sys. KW**	
Total	Sens‡			Total	Sens‡		Total	Sens‡		Total	Sens‡		Total	Sens‡					
<b>N4A330(A,G)KG Outdoor Section With EN(A,D)4X31L17* Indoor Section</b>																			
875	72 (22.2)	33.22	16.91	2.06	31.69	16.39	2.26	30.06	15.84	2.50	28.48	15.31	2.77	27.41	14.95	3.12			
	67 (19.4)	30.28	21.08	2.05	28.91	20.56	2.25	27.54	20.04	2.49	26.13	19.52	2.76	24.98	19.08	3.10			
	63 (17.2)††	28.16	20.25	2.04	27.05	19.80	2.25	25.78	19.28	2.49	24.46	18.76	2.76	22.86	18.13	3.08			
	62 (16.7)	28.07	25.27	2.05	26.80	26.56	2.25	25.71	25.71	2.48	24.60	24.60	2.76	23.29	23.29	3.08			
	57 (13.9)	27.67	27.67	2.04	26.71	26.71	2.25	25.67	25.67	2.48	24.55	24.55	2.76	23.26	23.26	3.08			
970	72 (22.2)	33.81	17.69	2.10	32.00	17.08	2.30	30.30	16.51	2.53	28.71	15.99	2.81	27.49	15.59	3.14			
	67 (19.4)	30.64	22.21	2.09	29.20	21.67	2.29	27.80	21.15	2.53	26.35	20.61	2.80	25.09	20.14	3.13			
	63 (17.2)††	28.55	21.32	2.08	27.34	20.83	2.29	26.03	20.31	2.52	24.67	19.76	2.79	23.13	19.14	3.11			
	62 (16.7)	28.67	28.67	2.09	27.47	27.47	2.29	26.36	26.36	2.52	25.20	25.20	2.80	24.14	24.14	3.14			
	57 (13.9)	28.57	28.57	2.09	27.43	27.43	2.29	26.33	26.33	2.52	25.14	25.14	2.79	24.21	24.21	3.13			
1125	72 (22.2)	34.10	18.74	2.16	32.36	18.17	2.36	30.60	17.59	2.60	28.93	17.05	2.87	27.70	16.66	3.20			
	67 (19.4)	31.10	23.99	2.15	29.57	23.42	2.36	28.11	22.88	2.59	26.63	22.32	2.86	25.46	21.89	3.21			
	63 (17.2)††	29.25	23.06	2.15	27.68	22.44	2.35	26.34	21.90	2.59	24.91	21.33	2.86	23.65	20.80	3.19			
	62 (16.7)	29.57	29.57	2.15	28.41	28.41	2.35	27.20	27.20	2.59	25.99	25.99	2.86	25.03	25.03	3.20			
	57 (13.9)	29.57	29.57	2.15	28.38	28.38	2.35	27.20	27.20	2.59	25.95	25.95	2.86	24.99	24.99	3.20			
<b>N4A336(A,G)KF Outdoor Section With EA*4X37L21A* Indoor Section</b>																			
1050	72 (22.2)	41.02	21.66	2.54	39.40	21.07	2.83	37.67	20.45	3.14	35.71	19.75	3.48	33.44	18.95	3.91			
	67 (19.4)	37.34	26.81	2.53	35.82	26.20	2.81	34.20	25.55	3.11	32.39	24.83	3.45	30.24	23.98	3.87			
	63 (17.2)††	34.68	25.78	2.53	33.23	25.15	2.81	31.71	24.49	3.10	29.97	23.75	3.44	27.94	22.89	3.85			
	62 (16.7)	34.09	31.81	2.53	32.69	31.14	2.81	31.25	31.03	3.10	29.79	29.79	3.44	28.17	28.17	3.85			
	57 (13.9)	33.44	33.44	2.53	32.31	32.31	2.81	31.10	31.10	3.10	29.74	29.74	3.43	28.12	28.12	3.85			
1200	72 (22.2)	41.67	22.87	2.60	40.00	22.28	2.90	38.19	21.64	3.21	36.16	20.93	3.56	33.84	20.12	3.98			
	67 (19.4)	37.97	28.72	2.59	36.42	28.10	2.88	34.74	27.44	3.18	32.86	26.71	3.52	30.66	25.85	3.93			
	63 (17.2)††	35.32	27.56	2.59	33.82	26.92	2.87	32.24	26.25	3.17	30.45	25.49	3.50	28.36	24.62	3.92			
	62 (16.7)	35.04	34.70	2.59	33.72	33.72	2.87	32.44	32.44	3.16	30.99	30.99	3.50	29.26	29.26	3.92			
	57 (13.9)	34.87	34.87	2.59	33.67	33.67	2.87	32.39	32.39	3.16	30.95	30.95	3.50	29.22	29.22	3.92			
1350	72 (22.2)	42.14	24.02	2.67	40.41	23.42	2.97	38.56	22.78	3.28	36.48	22.06	3.63	34.10	21.25	4.05			
	67 (19.4)	38.45	30.58	2.65	36.85	29.95	2.94	35.14	29.28	3.24	33.22	28.53	3.58	30.99	27.65	4.00			
	63 (17.2)††	35.80	29.28	2.65	34.26	28.63	2.93	32.63	27.95	3.23	30.83	27.19	3.57	28.68	26.27	3.98			
	62 (16.7)	36.12	36.12	2.65	34.86	34.86	2.93	33.50	33.50	3.23	31.98	31.98	3.57	30.16	30.16	3.99			
	57 (13.9)	36.07	36.07	2.65	34.81	34.81	2.93	33.45	33.45	3.23	31.94	31.94	3.57	30.12	30.12	3.99			



### Detailed Cooling Capacities# - Copper Coil Models (Continued)

EVAPORATOR AIR		CONDENSER ENTERING AIR TEMPERATURES °F (°C)																	
		75 (23.9)		85 (29.4)				95 (35)				105 (40.6)				115 (46.1)			
		CFM	EWB °F (°C)	Capacity MBtuh		Total Sys. KW**	Capacity MBtuh		Total Sys. KW**	Capacity MBtuh		Total Sys. KW**	Capacity MBtuh		Total Sys. KW**	Capacity MBtuh		Total Sys. KW**	
Total	Sens‡			Total	Sens‡		Total	Sens‡		Total	Sens‡		Total	Sens‡					
<b>N4A342(A,G)KN Outdoor Section With EA*4X42L21A* Indoor Section</b>																			
1275	72 (22.2)	48.80	25.83	3.03	46.63	25.00	3.35	44.37	24.15	3.73	41.99	23.27	4.17	39.49	22.35	4.68			
	67 (19.4)	44.50	31.73	2.97	42.51	30.90	3.28	40.44	30.04	3.64	38.27	29.15	4.07	35.97	28.21	4.58			
	63 (17.2)††	41.32	30.53	2.92	39.48	29.70	3.23	37.55	28.84	3.59	35.52	27.95	4.01	33.37	27.01	4.51			
	62 (16.7)	40.82	37.56	2.92	39.08	36.71	3.23	37.26	35.78	3.59	35.38	34.77	4.01	33.52	33.52	4.51			
	57 (13.9)	39.84	39.84	2.91	38.41	38.41	3.22	36.87	36.87	3.58	35.24	35.24	4.01	33.48	33.48	4.51			
1400	72 (22.2)	49.54	27.00	3.12	47.29	26.16	3.44	44.94	25.29	3.82	42.48	24.40	4.26	39.89	23.46	4.77			
	67 (19.4)	45.19	33.62	3.05	43.14	32.78	3.36	41.00	31.91	3.73	38.77	31.01	4.16	36.40	30.06	4.66			
	63 (17.2)††	42.00	32.30	3.00	40.11	31.46	3.31	38.11	30.59	3.67	36.04	29.69	4.09	33.79	28.71	4.59			
	62 (16.7)	41.74	40.09	3.00	40.01	39.15	3.31	38.18	38.18	3.67	36.47	36.47	4.10	34.60	34.60	4.61			
	57 (13.9)	41.35	41.35	2.99	39.81	39.81	3.31	38.17	38.17	3.67	36.43	36.43	4.10	34.57	34.57	4.61			
1575	72 (22.2)	50.11	28.13	3.20	47.78	27.28	3.52	45.37	26.40	3.90	42.83	25.49	4.34	40.18	24.54	4.86			
	67 (19.4)	45.76	35.48	3.12	43.64	34.62	3.44	41.45	33.74	3.81	39.16	32.81	4.24	36.73	31.83	4.75			
	63 (17.2)††	42.56	34.03	3.08	40.60	33.17	3.39	38.55	32.28	3.75	36.40	31.34	4.17	34.14	30.34	4.67			
	62 (16.7)	42.60	42.59	3.08	41.00	41.00	3.40	39.27	39.27	3.76	37.44	37.44	4.20	35.48	35.48	4.71			
	57 (13.9)	42.59	42.59	3.08	40.96	40.96	3.39	39.22	39.22	3.76	37.40	37.40	4.20	35.44	35.44	4.71			
<b>N4A348(A,G)KG Outdoor Section With EA*4X60L21A* Indoor Section</b>																			
1275	72 (22.2)	53.20	26.31	3.12	50.85	25.14	3.54	48.37	23.95	4.02	45.80	22.76	4.56	43.04	21.54	5.16			
	67 (19.4)	48.41	32.16	3.11	46.26	30.89	3.51	43.98	29.61	3.99	41.58	28.31	4.54	39.04	26.99	5.14			
	63 (17.2)††	44.98	30.98	3.09	42.95	29.73	3.50	40.81	28.45	3.98	38.56	27.16	4.52	36.17	25.84	5.12			
	62 (16.7)	44.28	37.94	3.09	42.32	36.55	3.49	40.26	35.14	3.97	38.12	33.68	4.52	35.88	35.88	5.12			
	57 (13.9)	42.89	42.89	3.08	41.29	41.29	3.49	39.60	39.60	3.97	37.79	37.79	4.51	35.87	35.87	5.12			
1425	72 (22.2)	54.02	27.40	3.18	51.59	26.20	3.60	49.04	25.00	4.08	46.35	23.77	4.62	43.54	22.54	5.22			
	67 (19.4)	49.19	33.90	3.17	46.95	32.60	3.58	44.60	31.28	4.06	42.14	29.94	4.60	39.52	28.58	5.20			
	63 (17.2)††	45.73	32.61	3.15	43.63	31.31	3.56	41.42	30.00	4.04	39.10	28.67	4.58	36.64	27.31	5.19			
	62 (16.7)	45.16	40.27	3.15	43.16	38.80	3.56	41.10	37.27	4.04	39.09	39.09	4.58	37.07	37.07	5.19			
	57 (13.9)	44.41	44.41	3.15	42.73	42.73	3.55	40.93	40.93	4.04	39.04	39.04	4.58	37.01	37.01	5.19			
1575	72 (22.2)	54.66	28.45	3.24	52.17	27.23	3.65	49.54	25.99	4.14	46.79	24.75	4.68	43.91	23.49	5.29			
	67 (19.4)	49.79	35.58	3.23	47.50	34.25	3.64	45.10	32.89	4.12	42.56	31.51	4.66	39.90	30.11	5.27			
	63 (17.2)††	46.31	34.17	3.21	44.17	32.84	3.62	41.90	31.49	4.10	39.52	30.12	4.64	37.02	28.73	5.25			
	62 (16.7)	45.98	42.43	3.21	44.01	43.95	3.62	42.13	42.13	4.10	40.15	40.15	4.65	38.03	38.03	5.25			
	57 (13.9)	45.72	45.72	3.21	43.95	43.95	3.62	42.08	42.08	4.10	40.10	40.10	4.65	37.98	37.98	5.25			

## Detailed Cooling Capacities# - Copper Coil Models (Continued)

EVAPORATOR AIR		CONDENSER ENTERING AIR TEMPERATURES °F (°C)															
		75 (23.9)		85 (29.4)				95 (35)				105 (40.6)				115 (46.1)	
CFM	EWB °F (°C)	Capacity MBtuh		Total Sys.	Capacity MBtuh		Total Sys.	Capacity MBtuh		Total Sys.	Capacity MBtuh		Total Sys.	Capacity MBtuh		Total Sys.	
		Total	Sens‡	KW**	Total	Sens‡	KW**	Total	Sens‡	KW**	Total	Sens‡	KW**	Total	Sens‡	KW**	
		<b>N4A360(A,G)KN Outdoor Section With EA*4X60L24A* Indoor Section</b>															
1750	72 (22.2)	68.71	34.82	4.37	65.76	33.74	4.81	62.59	32.60	5.30	59.21	31.39	5.84	55.54	30.09	6.42	
	67 (19.4)	63.16	43.00	4.29	60.43	41.90	4.74	57.50	40.73	5.23	54.39	39.50	5.77	51.03	38.20	6.36	
	63 (17.2)††	59.15	41.80	4.24	56.59	40.69	4.68	53.84	39.50	5.18	50.92	38.26	5.72	47.79	36.96	6.31	
	62 (16.7)	58.14	51.13	4.23	55.65	49.99	4.67	53.01	48.77	5.16	50.27	47.45	5.71	47.55	47.55	6.31	
	57 (13.9)	56.63	56.63	4.21	54.60	54.60	4.66	52.42	52.42	5.16	50.09	50.09	5.71	47.55	47.55	6.31	
2000	72 (22.2)	69.71	36.45	4.48	66.67	35.37	4.92	63.38	34.20	5.41	59.88	32.98	5.95	56.07	31.67	6.53	
	67 (19.4)	64.15	45.67	4.40	61.31	44.55	4.85	58.27	43.36	5.34	55.05	42.13	5.87	51.58	40.80	6.46	
	63 (17.2)††	60.14	44.30	4.35	57.47	43.18	4.79	54.61	41.98	5.28	51.60	40.73	5.82	48.36	39.39	6.42	
	62 (16.7)	59.33	54.75	4.34	56.80	53.54	4.78	54.23	54.23	5.28	51.77	51.77	5.83	49.05	49.05	6.42	
	57 (13.9)	58.75	58.75	4.33	56.59	56.59	4.78	54.26	54.26	5.28	51.77	51.77	5.83	49.05	49.05	6.42	
2250	72 (22.2)	70.44	37.99	4.59	67.31	36.90	5.03	63.93	35.73	5.52	60.33	34.49	6.05	56.41	33.16	6.63	
	67 (19.4)	64.85	48.20	4.51	61.94	47.09	4.95	58.82	45.89	5.44	55.52	44.63	5.98	51.96	43.27	6.56	
	63 (17.2)††	60.84	46.68	4.45	58.11	45.56	4.90	55.17	44.34	5.39	52.08	43.07	5.93	48.77	41.69	6.52	
	62 (16.7)	60.44	60.44	4.45	58.18	58.18	4.90	55.72	55.72	5.40	53.10	53.10	5.94	50.23	50.23	6.54	
	57 (13.9)	60.47	60.47	4.45	58.19	58.19	4.90	55.73	55.73	5.40	53.10	53.10	5.94	50.23	50.23	6.54	

**NOTES:**

\* Tested combination.

† Total and sensible capacities are net capacities. Blower motor heat has been subtracted.

‡ Sensible capacities shown are based on 80°F (27°C) entering air at the indoor coil. For sensible capacities at other than 80°F (27°C), deduct 835 Btuh (245 kW) per 1000 CFM (480 L/S) of indoor coil air for each degree below 80°F (27°C), or add 835 Btuh (245 kW) per 1000 CFM (480 L/S) of indoor coil air per degree above 80°F (27°C).

# Detailed cooling capacities are based on indoor and outdoor unit at the same elevation per AHRI standard 210/240-2008. If additional tubing length and/or indoor unit is located above outdoor unit, a slight variation in capacity may occur.

\*\* System kw is total of indoor and outdoor unit kilowatts.

†† At TVA rating indoor condition (75°F edb/63°F ewb). All other indoor air temperatures are at 80°F edb.

**NOTE:** When the required data falls between the published data, interpolation may be performed. Extrapolation is not an acceptable practice.

**EWB** — Entering Wet Bulb

18 Manufacturer reserves the right to change, at any time, specifications and designs without notice and without obligations.





## DETAILED COOLING CAPACITIES# -ALUMINUM COIL MODELS (CONTINUED)

EVAPORATOR AIR		CONDENSER ENTERING AIR TEMPERATURES °F (°C)																	
		75 (23.9)			85 (29.4)			95 (35)			105 (40.6)			115 (46.1)			125 (51.7)		
		Capacity MBtuh	Total System KW**	Total System KW**	Capacity MBtuh	Total System KW**	Capacity MBtuh	Total System KW**	Capacity MBtuh	Total System KW**	Capacity MBtuh	Total System KW**	Capacity MBtuh	Total System KW**	Capacity MBtuh	Total System KW**	Capacity MBtuh	Total System KW**	
CFM	EWB °F (°C)																		Total
<b>N4A360(B,L)KA Outdoor Section With EA*4X60L24A* Indoor Section</b>																			
1750	72 (22.2)	68.98	35.64	4.35	65.79	34.47	4.74	62.26	33.19	5.17	58.52	31.85	5.69	54.57	30.46	6.29	50.50	29.04	7.01
	67 (19.4)	63.26	44.05	4.36	60.31	42.84	4.74	57.13	41.57	5.18	53.71	40.22	5.69	50.11	38.81	6.29	46.38	37.36	7.01
	63 (17.2)††	59.01	42.49	4.36	56.33	41.32	4.74	53.34	40.03	5.18	50.15	38.67	5.68	46.79	37.25	6.28	43.31	35.79	7.00
	62 (16.7)	58.26	52.26	4.36	55.70	51.05	4.74	52.86	49.66	5.17	49.91	49.61	5.68	47.09	47.09	6.28	44.16	44.16	7.00
2000	72 (22.2)	69.96	37.33	4.44	66.63	36.14	4.83	62.97	34.84	5.27	59.10	33.49	5.78	55.03	32.07	6.38	50.83	30.64	7.10
	67 (19.4)	64.22	46.79	4.46	61.19	45.60	4.84	57.87	44.29	5.28	54.33	42.91	5.78	50.62	41.46	6.39	46.80	39.96	7.10
	63 (17.2)††	59.97	45.06	4.46	57.19	43.88	4.84	54.09	42.56	5.27	50.79	41.17	5.78	47.33	39.70	6.38	43.76	38.18	7.10
	62 (16.7)	59.54	55.86	4.45	56.92	54.49	4.84	54.23	54.23	5.27	51.46	51.46	5.78	48.49	48.49	6.38	45.38	45.38	7.10
2250	72 (22.2)	70.64	38.95	4.54	67.22	37.72	4.92	63.39	36.41	5.36	59.47	35.04	5.87	55.31	33.61	6.48	51.02	32.16	7.20
	67 (19.4)	64.93	49.42	4.55	61.81	48.21	4.93	58.39	46.87	5.37	54.77	45.45	5.88	50.99	43.94	6.48	47.11	42.37	7.20
	63 (17.2)††	60.71	47.51	4.55	57.80	46.28	4.94	54.64	44.94	5.37	51.26	43.51	5.88	47.72	41.99	6.48	44.11	40.38	7.20
	62 (16.7)	61.28	57.47	4.55	58.34	58.34	4.94	55.63	55.63	5.37	52.71	52.71	5.88	49.59	49.59	6.48	46.33	46.33	7.20
	57 (13.9)	60.70	60.70	4.55	58.27	58.27	4.94	55.57	55.57	5.37	52.66	52.66	5.88	49.55	49.55	6.48	46.29	46.29	7.20

**NOTES:**

\* Tested combination.

† Total and sensible capacities are net capacities. Blower motor heat has been subtracted.

‡ Sensible capacities shown are based on 80°F (27°C) entering air at the indoor coil. For sensible capacities at other than 80°F (27°C), deduct 835 Btuh

(245 kW) per 1000 CFM (480 L/S) of indoor coil air for each degree below 80°F (27°C), or add 835 Btuh (245 kW) per 1000 CFM (480 L/S) of indoor coil air per degree above 80°F (27°C).

# Detailed cooling capacities are based on indoor and outdoor unit at the same elevation per AHRI standard 210/240-2008. If additional tubing length and/or indoor unit is located above outdoor unit, a slight variation in capacity may occur.

\*\* System kw is total of indoor and outdoor unit kilowatts.

†† At TVA rating indoor condition (75°F edb/63°F ewb). All other indoor air temperatures are at 80°F edb.

NOTE: When the required data falls between the published data, interpolation may be performed. Extrapolation is not an acceptable practice.

EWB — Entering Wet Bulb

NOTE: When the required data fall between the published data, interpolation may be performed. Extrapolation is not an acceptable practice.

**CONDENSER ONLY RATINGS\* (Copper Coil Models)**

SST °F (°C)		CONDENSER ENTERING AIR TEMPERATURES °F (°C)						
		55 (12.78)	65 (18.33)	75 (23.89)	85 (29.44)	95 (35.0)	105 (40.56)	115 (46.11)
<b>N4A318(A,G)KF</b>								
30 (-1.11)	TCG	16.90	15.70	14.60	13.60	12.60	10.50	9.30
	SDT	71.20	79.70	88.40	97.90	107.30	126.60	137.10
	KW	0.88	0.99	1.10	1.24	1.39	1.78	2.04
35 (1.67)	TCG	18.60	17.40	16.20	15.10	14.00	11.80	10.50
	SDT	71.50	80.80	89.50	98.90	108.20	127.40	138.00
	KW	0.86	0.98	1.10	1.24	1.40	1.78	2.06
40 (4.44)	TCG	20.40	19.10	17.90	16.70	15.60	13.20	11.80
	SDT	73.50	81.90	90.60	99.90	109.20	128.70	137.60
	KW	0.87	0.98	1.10	1.24	1.40	1.80	2.03
45 (7.22)	TCG	22.20	20.90	19.60	18.40	17.20	14.60	13.20
	SDT	73.40	83.10	91.70	101.00	110.30	129.40	138.50
	KW	0.84	0.97	1.09	1.24	1.40	1.80	2.04
50 (10.0)	TCG	24.10	22.70	21.40	20.20	18.90	16.20	14.60
	SDT	74.30	83.50	92.80	102.10	111.40	130.40	139.50
	KW	0.83	0.95	1.09	1.24	1.40	1.81	2.04
55 (12.78)	TCG	26.10	24.70	23.40	22.00	20.60	17.80	16.10
	SDT	75.50	84.80	94.00	103.30	112.50	131.50	140.30
	KW	0.81	0.94	1.08	1.23	1.40	1.81	2.04
<b>N4A324(A,G)KG</b>								
30 (-1.11)	TCG	18.60	18.00	17.40	16.60	15.80	14.90	13.80
	SDT	78.20	87.90	97.80	107.70	117.70	127.80	138.10
	KW	1.03	1.19	1.39	1.61	1.88	2.19	2.57
35 (1.67)	TCG	20.60	20.00	19.30	18.50	17.60	16.60	15.40
	SDT	79.80	89.50	99.30	109.10	119.10	129.20	139.30
	KW	1.04	1.20	1.39	1.62	1.89	2.21	2.59
40 (4.44)	TCG	22.70	22.10	21.30	20.50	19.50	18.40	17.20
	SDT	81.40	91.10	100.80	110.60	120.50	130.50	140.40
	KW	1.04	1.21	1.40	1.64	1.91	2.23	2.60
45 (7.22)	TCG	25.00	24.30	23.50	22.60	21.60	20.40	19.10
	SDT	83.10	92.80	102.40	112.10	121.90	131.80	141.60
	KW	1.04	1.21	1.41	1.65	1.92	2.24	2.62
50 (10.0)	TCG	27.50	26.70	25.80	24.90	23.80	22.50	21.10
	SDT	84.90	94.50	104.00	113.60	123.30	133.10	142.70
	KW	1.05	1.22	1.42	1.66	1.93	2.26	2.63
55 (12.78)	TCG	30.10	29.30	28.30	27.30	26.10	24.80	23.30
	SDT	86.70	96.20	105.70	115.20	124.80	134.40	143.90
	KW	1.05	1.22	1.43	1.66	1.94	2.27	2.64
<b>N4A330(A,G)KG</b>								
30 (-1.11)	TCG	26.40	24.90	23.20	21.70	20.20	18.70	17.10
	SDT	71.50	80.00	88.80	98.10	107.40	116.70	126.00
	KW	1.43	1.58	1.75	1.95	2.18	2.44	2.74
35 (1.67)	TCG	28.80	27.50	25.50	23.90	22.20	20.60	19.20
	SDT	71.70	81.30	89.90	99.20	108.40	117.70	127.20
	KW	1.41	1.58	1.75	1.96	2.19	2.45	2.76
40 (4.44)	TCG	31.90	29.60	27.90	26.20	24.40	22.60	20.70
	SDT	73.40	82.00	91.20	100.30	109.50	118.70	127.90
	KW	1.42	1.57	1.76	1.96	2.20	2.46	2.77
45 (7.22)	TCG	34.60	32.60	30.50	28.60	26.60	24.60	23.30
	SDT	74.50	83.50	92.50	101.60	110.70	119.70	129.40
	KW	1.42	1.58	1.76	1.97	2.20	2.47	2.80
50 (10.0)	TCG	37.40	35.60	33.40	31.10	29.00	26.70	25.40
	SDT	75.80	85.00	94.00	102.90	111.90	120.90	130.50
	KW	1.41	1.59	1.77	1.97	2.21	2.48	2.81
55 (12.78)	TCG	40.80	38.60	36.10	33.80	31.50	29.10	28.00
	SDT	77.50	86.50	95.30	104.30	113.20	122.10	132.00
	KW	1.41	1.59	1.77	1.98	2.22	2.49	2.83

**CONDENSER ONLY RATINGS\* (Copper Coil Models) (Continued)**

SST °F (°C)		CONDENSER ENTERING AIR TEMPERATURES °F (°C)						
		55 (12.78)	65 (18.33)	75 (23.89)	85 (29.44)	95 (35.0)	105 (40.56)	115 (46.11)
<b>N4A336(A,G)KF</b>								
30 (-1.11)	TCG	30.70	28.50	26.70	25.10	23.50	21.90	20.00
	SDT	70.70	80.00	89.40	98.80	108.20	117.60	127.00
	KW	1.61	1.94	2.21	2.47	2.73	3.03	3.41
35 (1.67)	TCG	33.70	31.40	29.50	27.80	26.10	24.30	22.20
	SDT	71.80	81.10	90.40	99.80	109.20	118.50	127.80
	KW	1.58	1.91	2.19	2.45	2.72	3.03	3.41
40 (4.44)	TCG	36.90	34.60	32.50	30.70	28.80	26.80	24.60
	SDT	72.90	82.20	91.50	100.90	110.20	119.40	128.60
	KW	1.55	1.89	2.17	2.44	2.71	3.02	3.41
45 (7.22)	TCG	40.40	37.90	35.80	33.80	31.70	29.50	27.10
	SDT	74.20	83.40	92.70	102.00	111.20	120.40	129.50
	KW	1.53	1.87	2.16	2.43	2.71	3.03	3.41
50 (10.0)	TCG	44.20	41.60	39.30	37.10	34.80	32.40	29.80
	SDT	75.50	84.70	94.00	103.20	112.30	121.40	130.50
	KW	1.52	1.86	2.16	2.44	2.72	3.04	3.43
55 (12.78)	TCG	48.20	45.50	43.00	40.60	38.10	35.50	32.60
	SDT	77.00	86.10	95.30	104.40	113.50	122.50	131.50
	KW	1.52	1.87	2.17	2.45	2.74	3.07	3.46
<b>N4A342(A,G)KN</b>								
30 (-1.11)	TCG	38.00	36.00	33.90	31.90	29.70	27.60	25.30
	SDT	73.20	82.30	91.40	100.60	109.80	119.10	128.40
	KW	1.95	2.20	2.48	2.80	3.14	3.53	3.95
35 (1.67)	TCG	41.90	39.70	37.40	35.10	32.80	30.50	28.00
	SDT	74.80	83.70	92.80	101.90	111.00	120.20	129.40
	KW	1.97	2.22	2.50	2.81	3.16	3.54	3.97
40 (4.44)	TCG	46.00	43.60	41.10	38.70	36.20	33.60	30.90
	SDT	76.40	85.20	94.20	103.20	112.20	121.30	130.40
	KW	1.98	2.23	2.52	2.83	3.18	3.56	3.98
45 (7.22)	TCG	50.30	47.70	45.10	42.40	39.60	36.80	33.90
	SDT	78.10	86.90	95.70	104.60	113.50	122.50	131.40
	KW	2.01	2.26	2.54	2.85	3.19	3.58	4.00
50 (10.0)	TCG	54.90	52.10	49.20	46.20	43.20	40.20	37.00
	SDT	80.00	88.60	97.20	106.00	114.80	123.70	132.50
	KW	2.03	2.28	2.56	2.87	3.21	3.60	4.01
55 (12.78)	TCG	59.70	56.60	53.40	50.20	46.90	43.50	40.10
	SDT	81.90	90.30	98.90	107.50	116.20	124.90	133.60
	KW	2.06	2.30	2.58	2.89	3.23	3.62	4.03
<b>N4A348(A,G)KG</b>								
30 (-1.11)	TCG	39.10	37.90	36.60	35.10	33.40	31.50	29.40
	SDT	72.80	82.00	91.40	100.60	110.00	119.20	128.40
	KW	2.02	2.26	2.58	2.98	3.45	3.99	4.60
35 (1.67)	TCG	43.00	41.70	40.20	38.60	36.80	34.80	32.60
	SDT	74.20	83.40	92.60	101.90	111.10	120.30	129.40
	KW	2.04	2.29	2.61	3.01	3.49	4.03	4.64
40 (4.44)	TCG	47.20	45.80	44.20	42.40	40.50	38.30	35.90
	SDT	75.80	84.90	94.00	103.20	112.40	121.50	130.50
	KW	2.06	2.31	2.64	3.05	3.53	4.08	4.69
45 (7.22)	TCG	51.80	50.20	48.40	46.50	44.40	42.10	39.50
	SDT	77.40	86.50	95.50	104.60	113.70	122.70	131.70
	KW	2.08	2.34	2.67	3.08	3.57	4.12	4.73
50 (10.0)	TCG	56.70	54.90	53.00	50.90	48.60	46.10	43.30
	SDT	79.20	88.10	97.10	106.10	115.10	124.00	132.90
	KW	2.10	2.36	2.70	3.12	3.60	4.16	4.77
55 (12.78)	TCG	62.00	60.00	57.90	55.60	53.10	50.30	47.20
	SDT	81.10	89.90	98.80	107.70	116.60	125.40	134.20
	KW	2.11	2.38	2.73	3.14	3.63	4.19	4.81

**CONDENSER ONLY RATINGS\* (Copper Coil Models) (Continued)**

SST °F (°C)		CONDENSER ENTERING AIR TEMPERATURES °F (°C)						
		55 (12.78)	65 (18.33)	75 (23.89)	85 (29.44)	95 (35.0)	105 (40.56)	115 (46.11)
<b>N4A360(A,G)KN</b>								
30 (-1.11)	TCG	53.70	51.10	48.30	45.40	42.30	39.20	36.10
	SDT	75.80	84.90	94.10	103.10	112.20	121.30	130.40
	KW	2.65	3.00	3.38	3.78	4.24	4.77	5.38
35 (1.67)	TCG	58.90	56.10	53.00	49.80	46.50	43.20	39.70
	SDT	77.50	86.60	95.70	104.70	113.60	122.60	131.60
	KW	2.72	3.06	3.43	3.84	4.29	4.82	5.44
40 (4.44)	TCG	64.60	61.40	58.00	54.50	50.90	47.20	43.40
	SDT	79.40	88.40	97.30	106.20	115.10	124.00	132.90
	KW	2.79	3.13	3.50	3.90	4.35	4.88	5.50
45 (7.22)	TCG	70.60	67.00	63.30	59.40	55.50	51.40	47.30
	SDT	81.40	90.30	99.10	107.90	116.70	125.40	134.20
	KW	2.87	3.20	3.56	3.97	4.42	4.95	5.56
50 (10.0)	TCG	76.90	73.00	68.80	64.60	60.20	55.70	51.20
	SDT	83.50	92.20	100.90	109.60	118.30	126.90	135.60
	KW	2.95	3.29	3.64	4.04	4.50	5.03	5.64
55 (12.78)	TCG	83.60	79.20	74.60	69.90	65.10	60.20	55.20
	SDT	85.80	94.30	102.90	111.40	119.90	128.50	137.00
	KW	3.05	3.38	3.73	4.13	4.59	5.12	5.73

**NOTES:**

\* Tested combination.

† Total and sensible capacities are net capacities. Blower motor heat has been subtracted.

‡ Sensible capacities shown are based on 80°F (27°C) entering air at the indoor coil. For sensible capacities at other than 80°F (27°C), deduct 835 Btuh (245 kW) per 1000 CFM (480 L/S) of indoor coil air for each degree below 80°F (27°C), or add 835 Btuh (245 kW) per 1000 CFM (480 L/S) of indoor coil air per degree above 80°F (27°C).

# Detailed cooling capacities are based on indoor and outdoor unit at the same elevation per AHRI standard 210/240-2008. If additional tubing length and/or indoor unit is located above outdoor unit, a slight variation in capacity may occur.

\*\* System kw is total of indoor and outdoor unit kilowatts.

†† At TVA rating indoor condition (75°F edb/63°F ewb). All other indoor air temperatures are at 80°F edb.

**EWB** — Entering Wet Bulb**NOTE:** When the required data fall between the published data, interpolation may be performed. Extrapolation is not an acceptable practice.1.

\* AHRI listing applies only to systems shown in Combination Ratings table.

**KW**- Outdoor Unit Kilowatts Only.**SDT**-Saturated Temperature Leaving Compressor (°F)**SST**-Saturated Temperature Entering Compressor (°F/°C)**TCG**-Gross Cooling Capacity (1000 Btuh)



### Condenser Only Ratings (Aluminum Coil Models)

SST °F (°C)		CONDENSER ENTERING AIR TEMPERATURES °F (°C)						
		55 (12.8)	65 (18.3)	75 (23.9)	85 (29.4)	95 (35)	105 (40.6)	115 (46.1)
<b>N4A318(B,L)KA</b>								
30 (-1.1)	TCG	15.70	14.70	13.70	12.70	11.80	10.90	9.90
	SDT	70.80	80.10	89.40	98.90	108.30	117.70	127.10
	KW	0.85	0.97	1.09	1.22	1.37	1.54	1.74
35 (1.7)	TCG	17.30	16.20	15.20	14.20	13.20	12.20	11.10
	SDT	71.90	81.10	90.50	99.90	109.30	118.60	128.00
	KW	0.85	0.96	1.09	1.22	1.38	1.55	1.75
40 (4.4)	TCG	19.00	17.90	16.80	15.70	14.70	13.60	12.40
	SDT	73.00	82.30	91.60	100.90	110.30	119.60	128.80
	KW	0.84	0.96	1.08	1.22	1.38	1.55	1.75
45 (7.2)	TCG	20.80	19.60	18.50	17.40	16.20	15.10	13.80
	SDT	74.20	83.40	92.70	102.00	111.30	120.70	129.90
	KW	0.83	0.95	1.08	1.22	1.38	1.56	1.76
50 (10)	TCG	22.70	21.50	20.30	19.10	17.90	16.70	15.30
	SDT	75.40	84.60	93.90	103.20	112.50	121.70	131.00
	KW	0.82	0.94	1.08	1.22	1.38	1.56	1.77
55 (12.8)	TCG	24.70	23.40	22.20	21.00	19.70	18.40	17.00
	SDT	76.70	85.90	95.20	104.40	113.70	122.90	132.00
	KW	0.81	0.93	1.07	1.22	1.38	1.56	1.77
<b>N4A324(B,L)KA</b>								
30 (-1.1)	TCG	21.00	19.90	18.80	17.60	16.30	15.00	13.70
	SDT	70.40	79.70	89.10	98.50	107.80	117.20	126.50
	KW	1.16	1.28	1.43	1.60	1.79	2.02	2.29
35 (1.7)	TCG	23.30	22.00	20.80	19.50	18.10	16.70	15.30
	SDT	71.60	80.90	90.20	99.50	108.90	118.20	127.50
	KW	1.15	1.28	1.42	1.60	1.79	2.03	2.29
40 (4.4)	TCG	25.60	24.30	22.90	21.50	20.10	18.50	17.00
	SDT	72.90	82.10	91.40	100.70	109.90	119.20	128.40
	KW	1.15	1.27	1.42	1.60	1.80	2.03	2.29
45 (7.2)	TCG	28.20	26.70	25.20	23.70	22.10	20.40	18.70
	SDT	74.30	83.50	92.70	101.90	111.10	120.30	129.40
	KW	1.14	1.27	1.42	1.60	1.80	2.03	2.30
50 (10)	TCG	30.90	29.20	27.60	25.90	24.20	22.40	20.60
	SDT	75.90	84.90	94.10	103.20	112.30	121.40	130.40
	KW	1.13	1.26	1.42	1.59	1.80	2.03	2.30
55 (12.8)	TCG	33.70	31.90	30.10	28.30	26.40	24.50	22.50
	SDT	77.50	86.50	95.50	104.50	113.50	122.50	131.40
	KW	1.11	1.25	1.41	1.59	1.80	2.03	2.30
<b>N4A330(B,L)KA</b>								
30 (-1.1)	TCG	24.50	23.30	22.00	20.80	19.40	18.00	16.50
	SDT	73.30	81.70	90.40	99.70	109.00	118.30	127.60
	KW	1.39	1.53	1.70	1.89	2.12	2.37	2.66
35 (1.7)	TCG	27.10	25.70	24.30	22.90	21.50	19.90	18.30
	SDT	73.80	83.10	91.70	101.00	110.20	119.40	128.60
	KW	1.38	1.54	1.70	1.90	2.13	2.38	2.68
40 (4.4)	TCG	29.70	28.20	26.80	25.20	23.70	22.00	20.20
	SDT	74.80	84.00	93.40	102.30	111.50	120.60	129.70
	KW	1.37	1.53	1.72	1.91	2.14	2.40	2.69
45 (7.2)	TCG	32.60	31.00	29.40	27.70	26.00	24.20	22.20
	SDT	76.50	85.60	94.60	103.70	112.80	121.80	130.70
	KW	1.38	1.54	1.72	1.92	2.15	2.41	2.71
50 (10)	TCG	35.70	33.90	32.20	30.40	28.50	26.50	24.40
	SDT	78.30	87.20	96.20	105.20	114.10	123.10	131.90
	KW	1.39	1.55	1.73	1.93	2.16	2.42	2.72
55 (12.8)	TCG	39.00	37.10	35.10	33.10	31.10	28.90	27.00
	SDT	80.10	88.90	97.80	106.70	115.60	124.40	134.00
	KW	1.40	1.56	1.74	1.94	2.17	2.44	2.77

## Condenser Only Ratings (Aluminum Coil Models) (Continued)

SST °F (°C)		CONDENSER ENTERING AIR TEMPERATURES °F (°C)						
		55 (12.8)	65 (18.3)	75 (23.9)	85 (29.4)	95 (35)	105 (40.6)	115 (46.1)
<b>N4A336(B,L)KA</b>								
30 (-1.1)	TCG	30.10	29.00	27.50	25.80	23.80	22.00	20.00
	SDT	71.70	81.20	90.60	99.90	110.00	118.30	127.50
	KW	1.65	1.95	2.21	2.45	2.72	2.99	3.35
35 (1.7)	TCG	33.40	32.10	30.40	28.60	26.30	24.40	22.30
	SDT	72.90	82.40	91.80	101.00	111.00	119.20	128.40
	KW	1.64	1.94	2.20	2.44	2.72	2.99	3.35
40 (4.4)	TCG	36.80	35.30	33.50	31.40	29.00	27.00	24.70
	SDT	74.30	83.70	93.00	102.10	112.10	120.30	129.40
	KW	1.63	1.93	2.19	2.44	2.72	2.99	3.36
45 (7.2)	TCG	40.40	38.70	36.70	34.40	31.80	29.60	27.20
	SDT	75.70	85.00	94.30	103.30	113.30	121.40	130.40
	KW	1.62	1.93	2.19	2.44	2.73	3.00	3.38
50 (10)	TCG	44.20	42.20	40.00	37.50	34.70	32.30	29.70
	SDT	77.20	86.50	95.60	104.60	114.50	122.50	131.40
	KW	1.62	1.93	2.19	2.44	2.74	3.02	3.40
55 (12.8)	TCG	48.10	45.90	43.40	40.70	37.70	35.10	32.20
	SDT	78.90	88.10	97.10	106.00	115.70	123.70	132.40
	KW	1.63	1.94	2.20	2.46	2.76	3.05	3.42
<b>N4A342(B,L)KA</b>								
30 (-1.1)	TCG	36.70	34.90	33.10	31.30	29.30	27.30	25.20
	SDT	70.70	80.00	89.40	98.70	108.10	117.50	126.80
	KW	1.96	2.19	2.43	2.71	3.02	3.36	3.76
35 (1.7)	TCG	40.40	38.50	36.50	34.50	32.30	30.10	27.80
	SDT	72.00	81.20	90.50	99.80	109.20	118.40	127.70
	KW	1.97	2.20	2.44	2.72	3.03	3.39	3.78
40 (4.4)	TCG	44.50	42.30	40.10	37.90	35.60	33.10	30.60
	SDT	73.30	82.50	91.80	101.00	110.30	119.50	128.60
	KW	1.98	2.21	2.46	2.74	3.05	3.41	3.80
45 (7.2)	TCG	48.80	46.50	44.00	41.60	39.00	36.40	33.60
	SDT	74.90	84.00	93.10	102.30	111.40	120.50	129.60
	KW	1.99	2.22	2.47	2.75	3.07	3.42	3.82
50 (10)	TCG	53.50	50.90	48.20	45.50	42.70	39.80	36.80
	SDT	76.50	85.50	94.60	103.60	112.60	121.60	130.50
	KW	2.01	2.23	2.49	2.77	3.09	3.44	3.84
55 (12.8)	TCG	58.60	55.70	52.70	49.70	46.70	43.50	40.20
	SDT	78.20	87.10	96.00	105.00	113.90	122.70	131.60
	KW	2.02	2.24	2.50	2.78	3.10	3.46	3.86
<b>N4A348(B,L)KA</b>								
30 (-1.1)	TCG	41.20	39.10	37.00	34.70	32.40	30.00	27.40
	SDT	72.40	81.70	90.90	100.20	109.50	118.70	127.90
	KW	2.19	2.39	2.66	2.99	3.39	3.83	4.32
35 (1.7)	TCG	45.30	43.00	40.60	38.20	35.70	33.10	30.30
	SDT	73.80	83.00	92.20	101.40	110.60	119.80	129.00
	KW	2.21	2.41	2.69	3.03	3.43	3.87	4.37
40 (4.4)	TCG	49.70	47.10	44.50	41.90	39.10	36.30	33.40
	SDT	75.30	84.40	93.60	102.70	111.90	121.00	130.10
	KW	2.23	2.44	2.72	3.06	3.46	3.92	4.41
45 (7.2)	TCG	54.40	51.60	48.70	45.80	42.80	39.80	36.50
	SDT	77.00	86.00	95.10	104.20	113.30	122.30	131.20
	KW	2.25	2.46	2.75	3.10	3.50	3.96	4.45
50 (10)	TCG	59.50	56.40	53.20	50.00	46.80	43.40	40.00
	SDT	78.80	87.70	96.70	105.70	114.70	123.60	132.40
	KW	2.27	2.49	2.78	3.13	3.54	3.99	4.48
55 (12.8)	TCG	64.90	61.50	58.00	54.50	50.90	47.30	43.50
	SDT	80.70	89.60	98.40	107.30	116.10	124.90	133.70
	KW	2.28	2.51	2.81	3.16	3.57	4.02	4.52

**Condenser Only Ratings (Aluminum Coil Models) (Continued)**

SST °F (°C)		CONDENSER ENTERING AIR TEMPERATURES °F (°C)						
		55 (12.8)	65 (18.3)	75 (23.9)	85 (29.4)	95 (35)	105 (40.6)	115 (46.1)
<b>N4A360(B,L)KA</b>								
<b>30 (-1.1)</b>	TCG	54.30	52.10	49.40	46.40	43.10	39.60	36.00
	SDT	75.30	84.50	93.70	102.70	111.60	120.60	129.50
	KW	2.94	3.29	3.64	4.02	4.43	4.91	5.46
<b>35 (1.7)</b>	TCG	59.90	57.30	54.30	51.00	47.40	43.70	39.80
	SDT	77.20	86.30	95.30	104.20	113.10	121.90	130.70
	KW	2.99	3.34	3.68	4.05	4.47	4.95	5.51
<b>40 (4.4)</b>	TCG	65.70	62.80	59.50	55.80	51.90	47.90	43.80
	SDT	79.10	88.10	96.90	105.70	114.50	123.20	131.90
	KW	3.03	3.37	3.72	4.09	4.50	4.99	5.56
<b>45 (7.2)</b>	TCG	71.80	68.50	64.90	60.90	56.60	52.30	47.80
	SDT	81.00	89.90	98.60	107.30	115.90	124.60	133.10
	KW	3.06	3.40	3.74	4.11	4.53	5.02	5.59
<b>50 (10)</b>	TCG	78.20	74.50	70.40	66.10	61.50	56.70	51.90
	SDT	83.10	91.70	100.30	108.90	117.40	125.90	134.40
	KW	3.08	3.41	3.75	4.13	4.55	5.04	5.62
<b>55 (12.8)</b>	TCG	84.80	80.70	76.20	71.40	66.40	61.30	56.10
	SDT	85.10	93.60	102.10	110.50	118.90	127.30	135.70
	KW	3.08	3.40	3.75	4.13	4.56	5.05	5.64

\* AHRI listing applies only to systems shown in Combination Ratings table.

**KW** - Outdoor Unit Kilowatts Only.

**SDT** -Saturated Temperature Leaving Compressor (°F)

**SST** -Saturated Temperature Entering Compressor (°F/°C)

**TCG** -Gross Cooling Capacity (1000 Btuh)

## GUIDE SPECIFICATIONS GENERAL

### System Description

Outdoor-mounted, air-cooled, split-system air conditioner unit suitable for ground or rooftop installation. Unit consists of a hermetic compressor, an air-cooled coil, propeller-type condenser fan, and a control box. Unit will discharge supply air upward as shown on contract drawings. Unit will be used in a refrigeration circuit to match up to a packaged fan coil or coil unit.

### Quality Assurance

- Unit will be rated in accordance with the latest edition of AHRI Standard 210.
- Unit will be certified for capacity and efficiency, and listed in the latest AHRI directory.
- Unit construction will comply with latest edition of ANSI/ASHRAE and with NEC.
- Unit will be constructed in accordance with UL standards and will carry the UL label of approval. Unit will have c-UL-us approval.
- Unit cabinet will be capable of withstanding Federal Test Method Standard No. 141 (Method 6061) 500-hr salt spray test.
- Air-cooled condenser coils will be leak tested at 150 psig and pressure tested at 450 psig.
- Unit constructed in ISO9001 approved facility.

### Delivery, Storage, and Handling

- Unit will be shipped as single package only and is stored and handled per unit manufacturer's recommendations.

### Warranty (for inclusion by specifying engineer)

- U.S. and Canada only.

## PRODUCTS

### Equipment

Factory assembled, single piece, air-cooled air conditioner unit. Contained within the unit enclosure is all factory wiring, piping, controls, compressor, refrigerant charge R-410A, and special features required prior to field start-up.

### Unit Cabinet

- Unit cabinet will be constructed of galvanized steel, bonderized, and coated with a powder coat paint.

### Fans

- Condenser fan will be direct-drive propeller type, discharging air upward.
- Condenser fan motors will be totally enclosed, 1-phase type with class B insulation and permanently lubricated bearings. Shafts will be corrosion resistant.
- Fan blades will be statically and dynamically balanced.
- Condenser fan openings will be equipped with coated steel wire safety guards.

## Air-cooled, split-system air conditioner N4A3

### 1-1/2 to 5 nominal tons

### Compressor

- Compressor will be hermetically sealed.
- Compressor will be mounted on rubber vibration isolators.

### Condenser Coil

- Condenser coil will be air cooled.
- Coil will be constructed of aluminum fins mechanically bonded to copper or aluminum tubes which are then cleaned, dehydrated, and sealed.

### Refrigeration Components

- Refrigeration circuit components will include liquid-line shutoff valve with sweat connections, vapor-line shutoff valve with sweat connections, system charge of R-410A refrigerant, and compressor oil.
- Unit will be equipped with low pressure switch and filter drier for R-410A refrigerant.

### Operating Characteristics

- The capacity of the unit will meet or exceed \_\_\_\_\_ Btuh at a suction temperature of \_\_\_\_\_ °F/°C. The power consumption at full load will not exceed \_\_\_\_\_ kW.
- Combination of the unit and the evaporator or fan coil unit will have a total net cooling capacity of \_\_\_\_\_ Btuh or greater at conditions of \_\_\_\_\_ CFM entering air temperature at the evaporator at \_\_\_\_\_ °F/°C wet bulb and \_\_\_\_\_ °F/°C dry bulb, and air entering the unit at \_\_\_\_\_ °F/°C.
- The system will have a SEER of \_\_\_\_\_ Btuh/watt or greater at DOE conditions.

### Electrical Requirements

- Nominal unit electrical characteristics will be \_\_\_\_\_ v, single phase, 60 hz. The unit will be capable of satisfactory operation within voltage limits of \_\_\_\_\_ v to \_\_\_\_\_ v.
- Nominal unit electrical characteristics will be \_\_\_\_\_ v, three phase, 60 hz. The unit will be capable of satisfactory operation within voltage limits of \_\_\_\_\_ v to \_\_\_\_\_ v.
- Unit electrical power will be single point connection.
- Control circuit will be 24v.

### Special Features

- Refer to section of this literature identifying accessories and descriptions for specific features and available enhancements.

## SYSTEM DESIGN SUMMARY

1. Intended for outdoor installation with free air inlet and outlet. Outdoor fan external static pressure available is less than 0.01-IN W.C.
2. Minimum outdoor operating air temperature without low-ambient operation accessory is 55°F (12.8°C).
3. Maximum outdoor operating air temperature is 115°F (46.1°C).
4. For reliable operation, unit should be level in all horizontal planes.
5. For interconnecting refrigerant tube lengths greater than 80 ft (23.4 m) and/or 35 ft (10.7 m) vertical differential, consult Residential Piping and Longline Guideline and Service Manual available from equipment distributor.
6. If any refrigerant tubing is buried, provide a 6 in. (152.4 mm) vertical rise to the valve connections at the unit. Refrigerant tubing lengths up to 36 in. (914.4 mm) may be buried without further consideration. Do not bury refrigerant lines longer than 36 in. (914.4 mm).
7. Use only copper wire for electric connection at unit. Aluminum and clad aluminum are not acceptable for the type of connector provided.
8. Do not apply capillary tube indoor coils to these units.
9. Factory-supplied filter drier must be installed.

