

Pressure Relief Valves

Selection Process

While valves are designed to reseal after discharge, it is advisable that they are replaced, since system impurities such as piping debris, solder, and metal shavings can accumulate under the valve disc and inhibit the proper resealing of the valve.

Selection of a relief valve should be based on the discharge capacity required for the system or vessel, based on the size of the equipment and the refrigerant being used. Minimum settings for valves should be at least 25% above the designed Maximum Operating Pressure, while additional consideration must be given if the valve location may experience high ambient temperatures such as an equipment room or rooftop. Sizing valves to the maximum allowable setting will minimize the possibility of seepage or early discharge.

Relief valves operate automatically when the system pressure exceeds the valve set pressure and exerts a force on the valve disc that overcomes the opposing internal spring force. By code, valves may open with allowable tolerances within a +/- 3% range of stamped set pressure, with full discharge capacity realized at 10% above the actual opening pressure.

Relief valves conform to the American Standard Safety Code for Mechanical Refrigeration (ANSI/SHRAE 15), and are designed and manufactured in accordance with ASME Section VIII Division I., certifying specific capacities and identified by the ASME and National Board NB stamps on each valve. These valves are also compliant with European Union Pressure Equipment Directive (PED 2014/68/EU), and exhibit the appropriate EC marking and identification number.

A Pressure Relief Valve (PRV) is a system safety device that has been designed to function in accordance with specific country codes to prevent and protect the operation of systems and vessels above the allowable safe levels.

Discharge Capacity

The minimum required discharge capacity of the pressure relief device or fusible plug for each pressure vessel is determined by the following formula, specified by the ASHRAE Standard 15, Safety Code for Mechanical Refrigeration:

$C = fDL$ where:

C = minimum required discharge capacity of the relief device, lb. air/min (kg air/sec)

D = outside diameter of vessel, ft (m)

L = length of the vessel, ft (m)

f = factor dependent on the kind of refrigerant from Discharge Capacity Chart

Example of relief valve selection:

Information for vessel being protected:

Diameter = 1.33 ft

Length = 3.33 ft

Working Pressure = 350 psi

Information from the table for f values:

Application = R-22

Value of f = 1.6

From the information provided, the required discharge capacity to protect the vessel is determined by solving the minimum discharge capacity formula: $C = fDL$

$C = (1.6)(3.33)(1.33)$

$C = 7.1$ lbs of air/min

Using the calculated discharge 7.1 lbs of air/min and the required pressure of 350 psi, we can select from the product offering.

Using the discharge capacity table, select the row for 350 psi. Valves with capacities that meet the minimum discharge requirement, 7.1, are viable options. Discharge table values A-K allows for selection of a valve based on the inlet and outlet sizes and configurations.

If the desired valve is to have a 3/8" NPTFE inlet and 3/8" Flare outlet, with the outlet being 90°, valve A 15512 is acceptable since it has a discharge table rating of B.

Pressure Relief Valves

Selection Process

Application	Value of F	Metric Value of F
-------------	------------	-------------------

When used on the lowside of a limited-charge cascade system

R-11	1.0	0.082
R-113	1.0	0.082
R-114	1.6	0.131
R-115	2.5	0.203
R-1150	1.0	0.082
R-12	1.6	0.131
R-123	1.0	0.082
R-124	1.6	0.131
R-1270	1.6	0.131
R-13	2.0	0.163
R-134a	1.6	0.131
R-13B1	2.0	0.163
R-14	2.5	0.203
R-142b	1.0	0.082
R-143a	2.0	0.163
R-152a	1.0	0.082
R-170	1.0	0.082
R-22	1.6	0.131
R-23	1.0	0.082
R-290	1.0	0.082
R-32	1.0	0.082
R-401A	1.6	0.131
R-401B	1.6	0.131
R-401C	1.6	0.131
R-402A	2.5	0.203
R-402B	2.0	0.163
R-403A	2.0	0.163
R-403B	2.5	0.203
R-404A	2.5	0.203
R-405A	1.6	0.131
R-406A	1.6	0.131

Application	Value of F	Metric Value of F
-------------	------------	-------------------

When used on the lowside of a limited-charge cascade system

R-407A	2.0	0.163
R-407C	1.6	0.131
R-407D	1.6	0.131
R-407E	1.6	0.131
R-408A	2.0	0.163
R-409A	1.6	0.131
R-409B	1.6	0.131
R-407B	2.5	0.203
R-410A	2.5	0.203
R-410B	2.5	0.203
R-411A	1.6	0.131
R-411B	1.6	0.131
R-411C	1.6	0.131
R-412A	1.6	0.131
R-413A	2.0	0.163
R-414A	1.6	0.131
R-414B	1.6	0.131
R-500	1.6	0.131
R-502	2.5	0.203
R-503	2.0	0.163
R-507A	2.5	0.203
R-508A	1.0	0.082
R-508B	1.0	0.082
R-509A	2.5	0.203
R-600	1.0	0.082
R-600a	1.0	0.082
R-717	0.5	0.041
R-718	0.2	0.016
R-744	1.0	0.082
R-764	1.0	0.082

Pressure Relief Valves

Certification and Part Number Explanation

Certifications:

Conforms to ASME Section VIII, Division 1 and The National Board of Boiler and Pressure Vessel Inspectors, Certificate Number 16,564.

Conforms to Pressure Equipment Directive 2014/68/EU. CE Certification Number 69517, BSI Product Services Notified Body Number 0086.

Canadian Registration Number OG0314.9C.

Certification Documentation Levels:

Level 1 Certificate: A Certificate of Conformance can be provided based on customer request at the time of order placement, or after customer receipt of product. Information necessary to provide a Certificate of Conformance includes: customer name, purchase order number, manufacturing part number, quantity shipped and date of shipment.

Level 2 Certificate: A Certificate of Conformance on a UV-1 Form can be provided based on customer request at the time of order placement, or after customer receipt of product. Information necessary to provide a Certificate of Conformance includes: customer name, purchase order number, manufacturing part number, quantity shipped and date of shipment.

Level 3 Certificate: A Certificate of Conformance can be provided based on customer request at the time of order placement. A serialized certificate can be provided to document the pressure setting of each valve at the point of production.

Part Number Explanation:

Pressure Relief Valves are prefixed to designate the desired pressure setting.

Examples of part numbers using prefixes for the A 15502 relief valve:

To determine the applicable prefix, see chart below.

PSIG	Prefix	PSIG	Prefix
235	D	400	H
300	E	425	I
350	G	450	J

<u>Part Number</u>	<u>Pressure Setting</u>
AD15502	235 psig
AJ15502	450 psig
AQ15502-75	75 psig
AQ15502-240	240 psig
AX15502-475	475 psig
AW15502-625	625 psig

For valves required at non-standard pressure settings listed above, use the chart below to determine prefix by selecting the range at which your requirement falls into. Follow the part number with the exact pressure setting you require.

<u>PSIG Range</u>	<u>Prefix</u>	<u>PSIG Range</u>	<u>Prefix</u>
70 - 249	Q	451 - 550	X
251 - 349	R	551 - 700	W
351 - 449	S		

Pressure Relief Valves

Angle NPTFE to Flare

Features:

- Temperature Range: -40°F/300°F, -40°C/149°C
- Designed primarily for use on liquid receiver applications above the liquid refrigerant level (it is recommended that the factory be consulted before the valves are used on other applications)
- Satisfy ASHRAE Standard 15 code requirements for a refrigerant vessel safety device (Application information can also be found in ASHRAE Guide and Data Book)
- Comply with ASME code for unfired pressure vessels
- Discharge rates are certified by National Board of Boiler & Pressure Vessel Inspectors
- Designed for maximum discharge capacities
- Conforms to Pressure Equipment Directive 2014/68/EU, CRN, Compatible with all CFC, HCFC and HFC refrigerants and oils



Part Number ***	NPTFE A (in)	Flare Outlet B	C (in)	C (mm)	D(in)	D (mm)	Wt (lb)	Wt (kg)	Discharge Table	Working Pressure
A 15512	3/8	3/8	2.43	62	1.21	31	0.37	0.17	B	150 - 700 psi
A 15513	3/8	1/2	2.43	62	1.34	34	0.37	0.17	B	150 - 700 psi
B 33746	1/4	3/8	2.43	62	1.21	31	0.34	0.15	B	150 - 700 psi
B 33754	1/4	1/2	2.43	62	1.34	34	0.43	0.19	B	150 - 700 psi
A 15514	1/2	5/8	4.10	104	1.56	40	1.02	0.46	C	150 - 700 psi
A 18784	3/8	1/2	4.10	104	1.56	40	1.15	0.52	C	150 - 700 psi

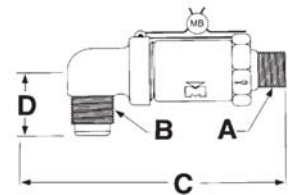

Prefix ***	PSIG	Discharge Capacity (lb air/min)										BAR	Discharge Capacity (kg air/min)															
		A	B	C	D	E	F	G	H	I	J		K	A	B	C	D	E	F	G	H	I	J	K				
D	235	4.3	9.1	20.1	33.7	55.9	91.8	39.0				29.0	60.6	90.3	16	2.0	4.1	9.1	15.3	25.4	41.6	17.7				13.2	27.5	41.0
E	300	5.4	11.5	25.4	42.5	70.5	115.8	49.2				36.6	76.5	113.9	21	2.4	5.2	11.5	19.3	32.0	52.5	22.3				16.6	34.7	51.7
G	350	6.3	13.3	29.5	49.3	81.8	134.3	57.1				42.4	88.7	132.1	24	2.9	6.0	13.4	22.4	37.1	60.9	25.9				19.2	40.2	59.9
H	400	7.1	15.2	33.5	56.1	93.0	152.7	64.9				48.2	150.3		28	3.2	6.9	15.2	25.4	42.2	69.3	29.4				21.9	68.2	
I	425	7.6	16.1	35.6	59.5	98.6	162.0	68.8				51.2	159.4		29	3.4	7.3	16.1	27.0	44.7	73.5	31.2				23.2	72.3	
J	450	8.0	17.0	37.6	62.9	104.3	171.2	72.8				54.1	168.5		31	3.6	7.7	17.1	28.5	47.3	77.7	33.0				24.5	76.4	
X	500		18.8	41.6											34		8.5	18.9										
W	550		20.7	45.6											38		9.4	20.7										
W	600		22.5	49.7											41		10.2	22.5										40.3
W	650		24.3	53.7											45		11.0	24.4										43.6
W	700		26.2	57.8											48		11.9	26.2										46.9

***Standard Pressure Setting Part Number Prefix

PSIG	Prefix	PSIG	Prefix
235	D	400	H
300	E	425	I
350	G	450	J

***Non-Standard Pressure Setting Part Number Prefixes:

PSIG Range	Prefix	PSIG Range	Prefix	
70 - 249	Q	451 - 550	X	Follow the part number with the pressure setting required.
251 - 349	R	551 - 700	W	
351 - 449	S			

Pressure Relief Valves

Atmospheric - NPTFE Inlet

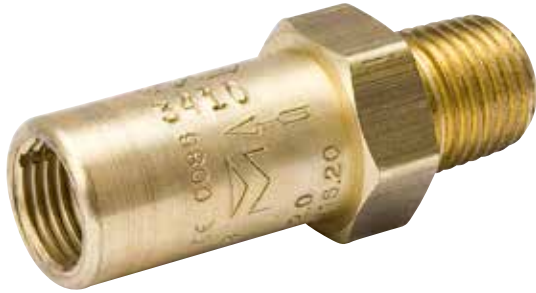

Features:

- Temperature Range: -40°F/300°F, -40°C/149°C
- Designed primarily for use on liquid receiver applications above the liquid refrigerant level (it is recommended that the factory be consulted before the valves are used on other applications)
- Satisfy ASHRAE Standard 15 code requirements for a refrigerant vessel safety device (Application information can also be found in ASHRAE Guide and Data Book)
- Comply with ASME code for unfired pressure vessels
- Discharge rates are certified by National Board of Boiler & Pressure Vessel Inspectors
- Designed for maximum discharge capacities
- Conforms to Pressure Equipment Directive 2014/68/EU, CRN, Compatible with all CFC, HCFC and HFC refrigerants and oils

Part Number ***	NPTFE Inlet A (in)	B (in)	B (mm)	C (in)	C (mm)	Wt (lb)	Wt (kg)	Discharge Table	Working Pressure
A 15508	1/8	1.88	48	0.75	19	0.12	0.05	A	150 - 450 psi
A 15509	1/4	2.00	51	0.75	19	0.14	0.06	A	150 - 450 psi
A 17430	3/8	2.12	54	1.00	25	0.25	0.11	B	150 - 700 psi
B 33755	1/4	2.12	54	1.00	25	0.30	0.14	B	150 - 700 psi

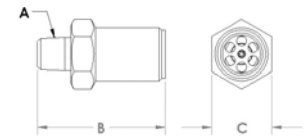

Prefix ***	PSIG	Discharge Capacity (lb air/min)										BAR	Discharge Capacity (kg air/min)															
		A	B	C	D	E	F	G	H	I	J		K	A	B	C	D	E	F	G	H	I	J	K				
D	235	4.3	9.1	20.1	33.7	55.9	91.8	39.0				29.0	60.6	90.3	16	2.0	4.1	9.1	15.3	25.4	41.6	17.7				13.2	27.5	41.0
E	300	5.4	11.5	25.4	42.5	70.5	115.8	49.2				36.6	76.5	113.9	21	2.4	5.2	11.5	19.3	32.0	52.5	22.3				16.6	34.7	51.7
G	350	6.3	13.3	29.5	49.3	81.8	134.3	57.1				42.4	88.7	132.1	24	2.9	6.0	13.4	22.4	37.1	60.9	25.9				19.2	40.2	59.9
H	400	7.1	15.2	33.5	56.1	93.0	152.7	64.9				48.2	150.3	28	3.2	6.9	15.2	25.4	42.2	69.3	29.4				21.9	68.2		
I	425	7.6	16.1	35.6	59.5	98.6	162.0	68.8				51.2	159.4	29	3.4	7.3	16.1	27.0	44.7	73.5	31.2				23.2	72.3		
J	450	8.0	17.0	37.6	62.9	104.3	171.2	72.8				54.1	168.5	31	3.6	7.7	17.1	28.5	47.3	77.7	33.0				24.5	76.4		
X	500		18.8	41.6										34		8.5	18.9											
W	550		20.7	45.6										38		9.4	20.7											
W	600		22.5	49.7										41		10.2	22.5									40.3		
W	650		24.3	53.7										45		11.0	24.4									43.6		
W	700		26.2	57.8										48		11.9	26.2									46.9		

***Standard Pressure Setting Part Number Prefixes:

PSIG	Prefix	PSIG	Prefix
235	D	400	H
300	E	425	I
350	G	450	J

***Non-Standard Pressure Setting Part Number Prefixes:

PSIG Range	Prefix	PSIG Range	Prefix
70 - 249	Q	451 - 550	X
251 - 349	R	551 - 700	W
351 - 449	S		

Follow the part number with the pressure setting required.

Pressure Relief Valves

Internal

Features:

- Temperature Range: -40°F/300°F, -40°C/149°C
- Designed primarily for use on liquid receiver applications above the liquid refrigerant level (it is recommended that the factory be consulted before the valves are used on other applications)
- Satisfy ASHRAE Standard 15 code requirements for a refrigerant vessel safety device (Application information can also be found in ASHRAE Guide and Data Book)
- Comply with ASME code for unfired pressure vessels
- Discharge rates are certified by National Board of Boiler & Pressure Vessel Inspectors
- Designed for maximum discharge capacities
- Conforms to Pressure Equipment Directive 2014/68/EU, CRN, Compatible with all CFC, HCFC and HFC refrigerants and oils



Part Number ***	NPTFE A (in)	B (in)	B (mm)	C (in)	C (mm)	Wt (lb)	Wt (kg)	Discharge Table	Working Pressure
B 34425	3/4	1.65	42	1.13	29	0.36	0.16	B	150 - 700 psi
A 17970	1	2.37	60	1.31	33	0.57	0.26	I	150 - 450 psi
A 18473	1 1/2	3.14	80	1.90	48	1.73	0.78	F	150 - 450 psi

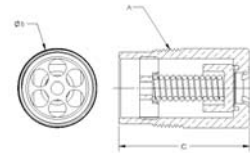

Prefix ***	PSIG	Discharge Capacity (lb air/min)										BAR	Discharge Capacity (kg air/min)									
		A	B	C	D	E	F	G	H	I	J		K	A	B	C	D	E	F	G	H	I
D	235	4.3	9.1	20.1	33.7	55.9	91.8	39.0	29.0	60.6	90.3	16	2.0	4.1	9.1	15.3	25.4	41.6	17.7	13.2	27.5	41
E	300	5.4	11.5	25.4	42.5	70.5	115.8	49.2	36.6	76.5	113.9	21	2.4	5.2	11.5	19.3	32.0	52.5	22.3	16.6	34.7	51
G	350	6.3	13.3	29.5	49.3	81.8	134.3	57.1	42.4	88.7	132.1	24	2.9	6.0	13.4	22.4	37.1	60.9	25.9	19.2	40.2	59
H	400	7.1	15.2	33.5	56.1	93.0	152.7	64.9	48.2	150.3	28	3.2	6.9	15.2	25.4	42.2	69.3	29.4	21.9	43.6	68	
I	425	7.6	16.1	35.6	59.5	98.6	162.0	68.8	51.2	159.4	29	3.4	7.3	16.1	27.0	44.7	73.5	31.2	23.2	45.7	72	
J	450	8.0	17.0	37.6	62.9	104.3	171.2	72.8	54.1	168.5	31	3.6	7.7	17.1	28.5	47.3	77.7	33.0	24.5	47.9	76	
X	500		18.8	41.6								34		8.5	18.9							
W	550		20.7	45.6								38		9.4	20.7							
W	600		22.5	49.7				88.9				41		10.2	22.5			40.3				
W	650		24.3	53.7				96.2				45		11.0	24.4			43.6				
W	700		26.2	57.8				103.4				48		11.9	26.2			46.9				

***Standard Pressure Setting Part Number Prefixes:

PSIG	Prefix	PSIG	Prefix
235	D	400	H
300	E	425	I
350	G	450	J

***Non-Standard Pressure Setting Part Number Prefixes:

PSIG Range	Prefix	PSIG Range	Prefix
70 - 249	Q	451 - 550	X
251 - 349	R	551 - 700	W
351 - 449	S		

Follow the part number with the pressure setting required.

Pressure Relief Valves

Straight Thru



Features:

- Temperature Range: -40°F/300°F, -40°C/149°C
- Designed primarily for use on liquid receiver applications above the liquid refrigerant level (it is recommended that the factory be consulted before the valves are used on other applications)
- Satisfy ASHRAE Standard 15 code requirements for a refrigerant vessel safety device (Application information can also be found in ASHRAE Guide and Data Book)
- Comply with ASME code for unfired pressure vessels
- Discharge rates are certified by National Board of Boiler & Pressure Vessel Inspectors
- Designed for maximum discharge capacities
- Conforms to Pressure Equipment Directive 2014/68/EU, CRN, Compatible with all CFC, HCFC and HFC refrigerants and oils

NPTFE Inlet to Flare Outlet

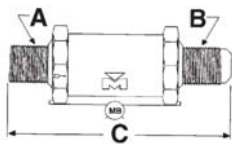

Part Number ****	NPTFE A (in)	Flare B (in)	C (in)	C (mm)	Wt (lb)	Wt (kg)	Discharge Table	Working Pressure
A 15501	1/4	3/8	2.65	67	0.20	0.09	A	150 - 450 psi
A 15502	3/8	3/8	2.81	71	0.34	0.15	B	150 - 700 psi
A 15503	3/8	1/2	3.00	76	0.35	0.16	B	150 - 700 psi
B 33752	1/4	3/8	2.81	71	0.00	0.00	B	150 - 700 psi
B 33753	1/4	1/2	3.00	76	0.41	0.18	B	150 - 700 psi
A 15504	1/2	5/8	4.20	107	0.84	0.38	C	150 - 700 psi
A 18737	3/8	5/8	4.20	107	0.98	0.45	C	150 - 700 psi
A 18783	3/8	1/2	4.20	107	0.95	0.43	C	150 - 700 psi

Prefix ***	PSIG	Discharge Capacity (lb air/min)										BAR	Discharge Capacity (kg air/min)											
		A	B	C	D	E	F	G	H	I	J		K	A	B	C	D	E	F	G	H	I	J	K
D	235	4.3	9.1	20.1	33.7	55.9	91.8	39.0		29.0	60.6	90.3	16	2.0	4.1	9.1	15.3	25.4	41.6	17.7		13.2	27.5	41
E	300	5.4	11.5	25.4	42.5	70.5	115.8	49.2		36.6	76.5	113.9	21	2.4	5.2	11.5	19.3	32.0	52.5	22.3		16.6	34.7	51
G	350	6.3	13.3	29.5	49.3	81.8	134.3	57.1		42.4	88.7	132.1	24	2.9	6.0	13.4	22.4	37.1	60.9	25.9		19.2	40.2	59
H	400	7.1	15.2	33.5	56.1	93.0	152.7	64.9		48.2		150.3	28	3.2	6.9	15.2	25.4	42.2	69.3	29.4		21.9		68
I	425	7.6	16.1	35.6	59.5	98.6	162.0	68.8		51.2		159.4	29	3.4	7.3	16.1	27.0	44.7	73.5	31.2		23.2		72
J	450	8.0	17.0	37.6	62.9	104.3	171.2	72.8		54.1		168.5	31	3.6	7.7	17.1	28.5	47.3	77.7	33.0		24.5		76
X	500		18.8	41.6									34		8.5	18.9								
W	550		20.7	45.6									38		9.4	20.7								
W	600		22.5	49.7					88.9				41		10.2	22.5					40.3			
W	650		24.3	53.7					96.2				45		11.0	24.4					43.6			
W	700		26.2	57.8					103.4				48		11.9	26.2					46.9			

***Standard Pressure Setting Part Number Prefixes:

PSIG	Prefix	PSIG	Prefix
235	D	400	H
300	E	425	I
350	G	450	J

***Non-Standard Pressure Setting Part Number Prefixes:

PSIG Range	Prefix	PSIG Range	Prefix	
70 - 249	Q	451 - 550	X	Follow the part number with the pressure setting required.
251 - 349	R	551 - 700	W	
351 - 449	S			

Pressure Relief Valves

Straight Thru

NPTFE Inlet to NPTFI Outlet

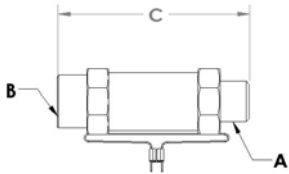

Part Number ***	NPTFE A (in)	NPTFI B (in)	C (in)	C (mm)	Wt (lb)	Wt (kg)	Discharge Table	Working Pressure	
A 18736	3/8	3/4	4.00	102	0.98	0.45	C	150 - 700 psi	
A 18762	1/2	3/4	4.00	102	0.94	0.43	C	150 - 700 psi	
A 15506	3/4	3/4	4.95	126	1.53	0.69	D	150 - 450 psi	
A 17840	1	1	4.60	117	1.45	0.66	E	150 - 450 psi	
A 18735	3/4	1	4.60	117	1.49	0.68	E	150 - 450 psi	
A 17834	1 1/4	1 1/4	4.94	125	2.00	0.91	F	150 - 450 psi	
A 18387	1	1	4.94	125	1.81	0.82	F	150 - 450 psi	
A 18356	1/2	1/2	3.99	101	0.96	0.43	G	150 - 450 psi	
A 18357	1/2	3/4	3.99	101	0.89	0.40	G	150 - 450 psi	
A 18358	3/4	3/4	3.99	101	0.93	0.42	G	150 - 450 psi	
AW18422	*	3/4	3/4	4.95	126	1.60	0.73	H	600 - 700 psi
A 18424	*	1	1	4.77	121	1.58	0.72	J	150 - 350 psi
A 18425	*	1 1/4	1 1/4	5.24	133	2.17	0.99	K	150 - 450 psi
A 18444	*	1	1 1/4	5.24	133	1.98	0.90	K	150 - 450 psi
*	PTFE Seat								

Straight Thread Inlet to Flare Outlet

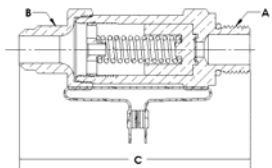

Part Number ***	Inlet A (in)	Outlet B (in)	C (in)	C (mm)	Wt (lb)	Wt (kg)	Discharge Table	Working Pressure
B 35413	7/8 - 14 UNF - 2A	5/8	4.19	106	0.92	0.42	C	150 - 700 psi

Straight Thread Inlet to NPTFI Outlet

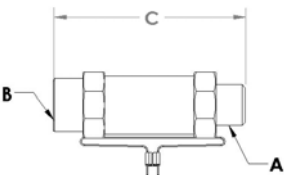

Part Number ***	Inlet A (in)	Outlet B (in)	C (in)	C (mm)	Wt (lb)	Wt (kg)	Discharge Table	Working Pressure
B 34444	7/8 - 14UNF - 2A	3/4	5.00	127	1.52	0.69	D	150 - 450 psi
B 34519	1 5/16 - 12UNF - 2S	1	4.38	111	1.37	0.62	E	150 - 450 psi
B 34580	1 5/8 - 12UNF - 2A	1 1/4	5.00	127	2.00	0.91	F	150 - 450 psi
A 18540	7/8 - 14UNF - 2A	3/4	3.99	101	0.96	0.44	G	150 - 450 psi

***Standard Pressure Setting Part Number Prefixes:

PSIG	Prefix	PSIG	Prefix
235	D	400	H
300	E	425	I
350	G	450	J

***Non-Standard Pressure Setting Part Number Prefixes:

PSIG Range	Prefix	PSIG Range	Prefix
70 - 249	Q	451 - 550	X
251 - 349	R	551 - 700	W
351 - 449	S		

Follow the part number with the pressure setting required.

Rupture Disc and Pressure Gauge

NPTFE X NPTFI



Features:

- Continuous operating temperature (COT): -40°F/300°F, -40°C/149°C
- Contact factory or visit website for compatibility with CFC, HCFC, HFC and HFO refrigerants and oils
- Conforms to Pressure Equipment Directive 2014/68/EU Category 4 Product, Certified to meet ASME Code
- Wide range of pressure settings available
- One-piece brass design assures setting accuracy
- Non-fragmenting disc

ASME Code

Guidelines for the application of Rupture Disc Devices in combination with pressure relief valves is provided by ASME Code. The following is an excerpt from the ASME Code, Section VIII, Division I, UG-127.

A rupture disc device may be installed between a pressure relief valve and the vessel provided:

The marked capacity of a pressure relief valve, when installed with a rupture disc device between the inlet of the valve and the vessel, shall be multiplied by a factor of 0.90 of the rated relieving capacity of the valve alone.

The space between a rupture disc device and a pressure relief valve shall be provided with a pressure gage, or suitable telltale indicator. This arrangement permits detection of disc rupture or leakage.

Users are warned that a rupture disc will not burst at its design pressure if back pressure build up in the space between the disc and the pressure relief valve which will occur should leakage develop in the rupture disc due to corrosion or other cause.

Part Number *	A NPTFE (in)	B NPTFI (in)	C NPT (in)	D (in)	D (mm)	E (in)	E (mm)	Wt (lb)	Wt (kg)
A 17971	1/2	1/2	1/8	3	71	1	13	0.51	0.23

Prefix	PSIG	Bar
D	235	16
E	300	21
G	350	24
H	400	28
I	425	29
J	450	31

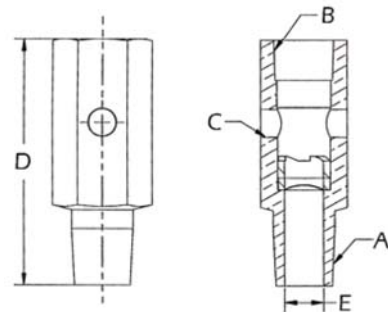

Pressure Gauge

P 36214

