



INSTALLATION, OPERATION & APPLICATION GUIDE

For more information on our complete range of American-made products – plus wiring diagrams, troubleshooting tips and more, visit us at www.icmcontrols.com



CAUTION!

Installation of the ICM333 shall be performed by trained technicians only. Adhere to all local and national electric codes.

DISCONNECT ALL POWER TO THE SYSTEM BEFORE MAKING ANY CONNECTIONS.

SPECIFICATIONS

- **Line Voltage:** 120, 208, 240, 277, 480 and 600 VAC
 - **Control Voltage:** 18 - 30 VAC
 - **Frequency:** 50-60 Hz
 - **Operating Temperature:** -40°F to +176°F (-40°C to +75°C)
 - **Probes:**
 - **Temperature:** Thermistor, 10K ohm at 77°F (25°C)
 - **Pressure:** ICM380 (ordered separately)
 - **Heat Pump Override:** 24 VAC N.C. or N.O.
 - **Weight:** 12 ounces (341 grams)
- * **Note:** The ICM333 should be applied to motors and equipment that have been designated by their respective manufacturers as capable of being speed controlled.
- **Mounting:**
 - Surface mount using (2) #8 screws
 - The ICM333 should be surface mounted to a clean metal or other thermally conductive surface for maximum heat dissipation
 - It is recommended that the ICM333 be mounted away from the condenser exhaust air in order to maintain lower operating temperatures

CONNECTIONS FOR ICM333 AT 120/208/240/277 VAC

1. Remove power from system.
2. Field install a wire from **Line 1** wire to **Line 1** terminal.
3. Cut **Line 2** wire; affix motor side to **Motor 2** terminal and line side to **Line 2** terminal.

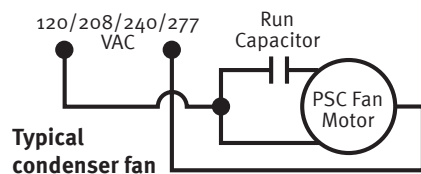

4. Make 24 VAC and temperature probe connections.
5. Verify wiring is correct.
6. Power up system and check operation.

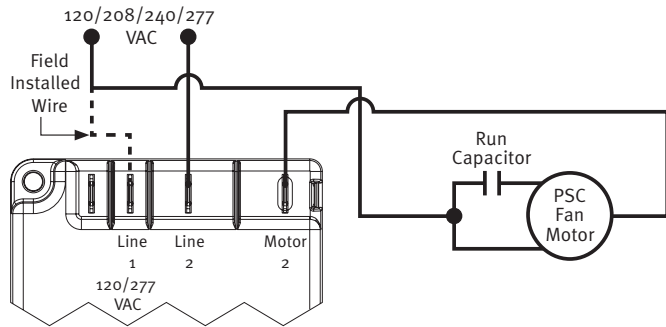

CONNECTIONS FOR ICM333 AT 480/600 VAC

1. Remove power from system.
2. Field install a wire from **Line 1** wire to **Line 1** terminal.
3. Cut **Line 2** wire; affix motor side to **Motor 2** terminal and line side to **Line 2** terminal.

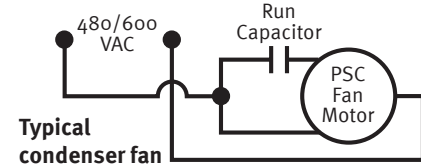

4. Make 24 VAC and temperature probe connections.
5. Verify wiring is correct.
6. Power up system and check operation.

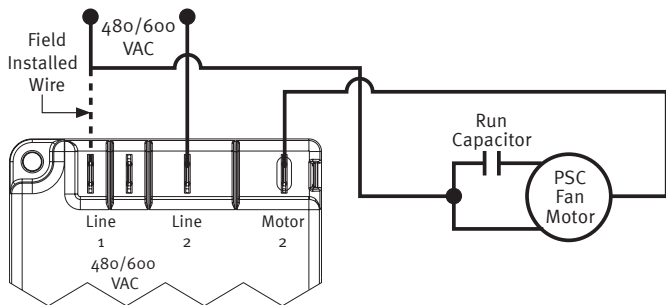

INSTALLING AND CONNECTING THE PROBE

1. Only one probe type can be used at a time, temperature or pressure. Up to two probes of a kind can be used in which case the control will respond to the probe that senses the highest temperature or pressure.
2. A typical installation is shown in Appendix. The temperature probe can be attached to the U-bend. Use the provided thermo-tape to secure the probe to the place of attachment.
3. When using a pressure probe, install it on the discharge line transducer fitting.
4. Temperature and Pressure probes are connected to ICM333 as shown in respective wiring diagrams below.

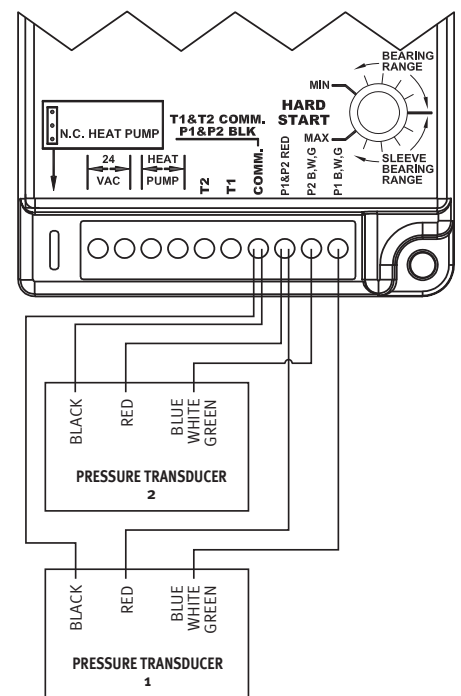
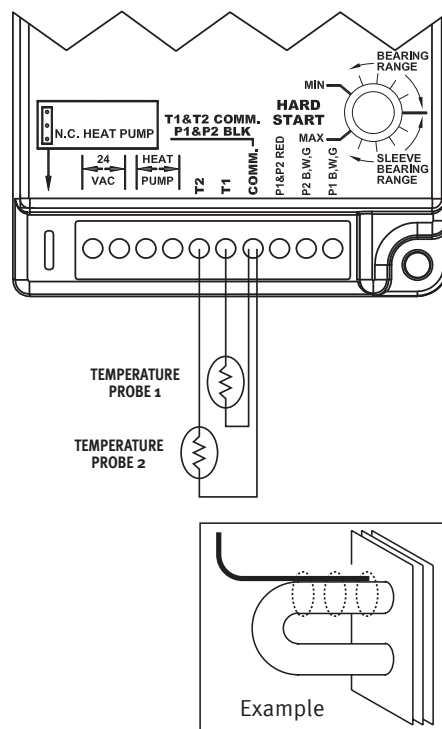

CONNECTIONS FOR HEAT PUMP SYSTEM AT 120/208/240/277 VAC

1. Remove power from system.
2. Field install a wire from **Line 1** wire to **Line 1** terminal.
3. Cut **Line 2** wire; affix the common from the defrost board's fan relay to the **Motor 2** terminal and the Line from the contactor to the **Line 2** terminal.

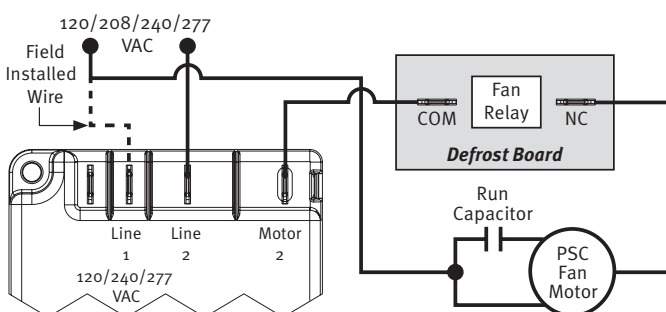

4. Make 24 VAC, probe and HP connections.
5. Verify wiring is correct.
6. Power up system and check operation.

CONNECTIONS FOR HEAT PUMP SYSTEM AT 480/600 VAC

1. Remove power from system.
2. Field install a wire from **Line 1** wire to **Line 1** terminal.
3. Cut **Line 2** wire; affix the common from the defrost board's fan relay to the **Motor 2** terminal and the Line from the contactor to the **Line 2** terminal.

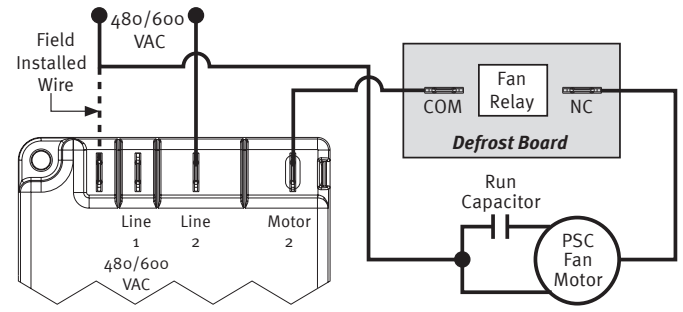

4. Make 24 VAC, probe and HP connections.
5. Verify wiring is correct.
6. Power up system and check operation.

CONNECTIONS FOR AIR CONDITIONING ONLY

1. For non-heat pump applications, the heat pump select jumper must be in the **Default (N.O.)** position, and the HP terminals must be left unconnected.
2. Set the Cutout Speed and the Hard Start Time to the appropriate positions for the type of motor you have (see below).

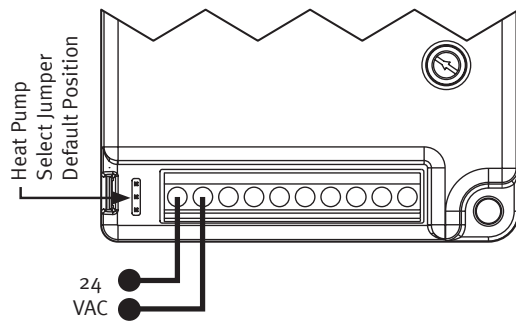

CONNECTIONS FOR HEAT PUMP SYSTEMS

1. The **Heat Pump** terminals accept the 24 VAC signal from the reversing valve holding coil. Make a parallel connection from the reversing valve to the HP terminals.
2. If the **Heat Pump** is in the **Heating** mode and the reversing valve is energized, then the **Heat Pump Select** jumper must be in the **Default (N.O.)** position.
3. If the **Heat Pump** is in the **Heating** mode and the reversing valve is not energized, then the **Heat Pump Select** jumper must be in the **N.C.** position.

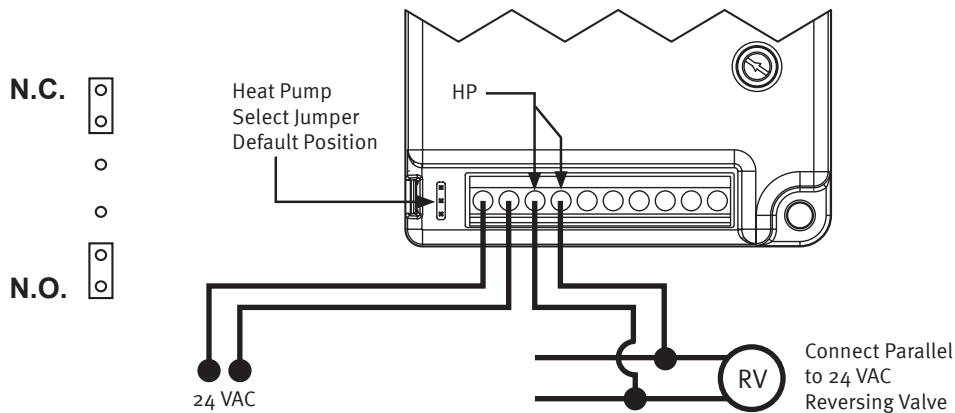

MODE OF OPERATIONS

When using temperature probes, the control will maintain condenser temperature between 7°F above and 7°F below dialed Temperature Setpoint. The dial Temperature Setpoint range is 70°F to 140°F

When using pressure probes, the control will maintain condenser pressure between 20psig above and 20psig below dialed Pressure Setpoint. The dial Pressure Setpoint range is 35psig to 465psig.

There is no correlation between dial temperature and pressure scales on the control

When the motor starts running it will hard start for the length of time dictated by the hard start dial setting. After the hard start time has elapsed, the motor speed is controlled by the probe reading, temperature or pressure. The green light turns on when the motor runs at full speed.

As the sensed temperature/pressure decreases, the output voltage decreases. The yellow light turns on during motor variable speed. The output voltage may decrease to the determined cutout speed dictated by the cutout speed dial. Upon reaching the cutout speed setting, the output voltage goes to zero volts. The yellow light turns off.

SETTING THE CUTOUT SPEED

The cutout speed dial adjusts the motor voltage range. Set the cutout voltage dial according to the type of motor you have.

Sleeve Bearing Motors: Set the cutout speed dial to the middle of the sleeve bearing range. In this range, the motor can run down approximately 40-50% of the full line voltage, which allows sufficient RPMs for cooling and lubrication.

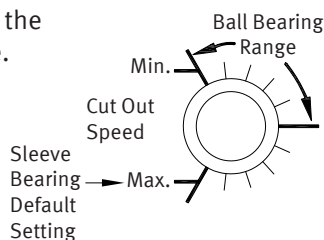

CAUTION! With sleeve bearing motors, it is important not to adjust outside the sleeve bearing range or bearing failure may result.

Ball Bearing Motors: Set the cutout speed dial to the **MIN** position in the ball bearing range. This position offers the greatest range of speed control. At the **MIN** setting the motor can run down to approximately 20-30% of the full line voltage.

* **Note:** After starting at the recommended settings for either sleeve or ball bearing motors, you can fine tune the cutout speed to achieve the desired results.

SETTING THE HARD START SPEED

During the **Hard Start** mode, full voltage is applied to the motor during startup to overcome windmilling and to lubricate the bearings.

The position of the hard start dial determines the time period of the hard start mode. The dial can be adjusted between 0.2 seconds and approximately 4 seconds.

Set the hard start dial according to the type of motor you have. If you have a **ball bearing motor**, set the hard start dial to the **MIN** position. If you have a **sleeve bearing motor**, set the hard start dial to the middle of the sleeve bearing range.

After you begin at the recommended setting, you can fine tune the hard start time within the recommended range for the type of motor you have.

It is recommended that you use the minimum possible hard start time to avoid blowing too much cold air over the condenser.

The hard start mode applies full voltage to the motor for the set time period. Afterwards, the motor speed is dictated by the temperature sensor(s).

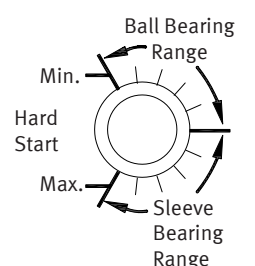

ONE-YEAR LIMITED WARRANTY

The Seller warrants its products against defects in material or workmanship for a period of one (1) year from the date of manufacture. The liability of the Seller is limited, at its option, to repair, replace or issue a non-case credit for the purchase prices of the goods which are provided to be defective. The warranty and remedies set forth herein do not apply to any goods or parts thereof which have been subjected to misuse including any use or application in violation of the Seller's instructions, neglect, tampering, improper storage, incorrect installation or servicing not performed by the Seller. In order to permit the Seller to properly administer the warranty, the Buyer shall: 1) Notify the Seller promptly of any claim, submitting date code information or any other pertinent data as requested by the Seller. 2) Permit the Seller to inspect and test the product claimed to be defective. Items claimed to be defective and are determined by Seller to be non-defective are subject to a \$30.00 per hour inspection fee. This warranty constitutes the Seller's sole liability hereunder and is in lieu of any other warranty expressed, implied or statutory. Unless otherwise stated in writing, Seller makes no warranty that the goods depicted or described herein are fit for any particular purpose.

TROUBLESHOOTING

Symptom	Problem
Unit fails to start	Using an AC voltmeter, measure the voltage between the 24VAC terminals. It should read approximately 24 volts. Measure the line voltage between LINE1 and LINE2 to confirm that line voltage is present. If lights are flashing alternatively then no probe is connected or malfunction probe. When using a temperature probe, disconnect it and use an ohmmeter to measure the resistance between the wires. It should match the chart in Appendix A. When using a pressure probe, with power applied to the control use a voltmeter to measure volts DC between COMM and P1 or P2 , where the wire is connected. The reading should be according to the chart in Appendix B.
The fuse is blown and/or signs of damage on the unit	The unit has been miswired and may be permanently damaged.
The fan cycles from ON to OFF with little or no speed modulation	Reduce hard start setting to minimum needed to accelerate the fan. Excessive hard start causes large pressure drops by running too much cold air over the condenser. Should the cycling persist, relocate the temperature probe up the condenser to increase sensitivity to temperature change and/or adjust the temperature setpoint.
The high pressure switch trips off	See Unit fails to start above Check the setpoint and reduce it if needed

APPENDIX

APPENDIX A

Temperature vs. Probe Resistance

°C	°F	Resistance (KΩ)
0°	32°	32.7
5°	41°	25.4
10°	50°	19.9
15°	59°	15.7
20°	68°	12.5
25°	77°	10.0
30°	86°	8.1
35°	95°	6.5
40°	104°	5.3
45°	113°	4.4
50°	122°	3.6

APPENDIX B

Pressure vs. Voltage

Pressure (psig)	Voltage (Vdc)
0	0.5
50	0.9
100	1.3
150	1.7
200	2.1
250	2.5
300	2.9
350	3.3
400	3.7
450	4.1
500	4.5

ICM333 TYPICAL INSTALLATION

