



Installation, Operation & Maintenance

Compact (HBH/HBV) Series

HBH-HBV 006-60

60Hz - HFC-410A

Table of Contents

Model Nomenclature – General Overview	3	Start-Up Log Sheet	74
General Information	4	Functional Troubleshooting	75
Unit Physical Data	6	Warranty	79
Horizontal Installation	7	Revision History	80
Field Conversion of Air Discharge	9		
Horizontal Installation	10		
Vertical Installation	11		
Piping Installation	13		
Water-Loop Heat Pump Applications	14		
Ground-Loop Heat Pump Applications	15		
Ground-Water Heat Pump Applications	17		
Water Quality Standards	19		
HB - Horizontal – Dimensional Data	20		
HBH with WSE – Dimensional Data	22		
HB - Horizontal Service Access	24		
HB - Vertical Upflow – Dimensional Data	25		
HBV with WSE – Dimensional Data	27		
HB - Vertical Service Access	29		
Electrical Data – PSC	30		
Electrical Data – ECM	31		
Electrical – Line Voltage	32		
Electrical – Power & Low Voltage Wiring	33		
Electrical – Low Voltage Wiring	34		
Electrical – Thermostat Wiring	35		
Blower Performance Data – HB006	36		
Blower Performance Data – HB009	37		
Blower Performance Data – HB012	38		
Blower Performance Data – HB015	39		
Blower Performance Data – HB018	40		
Blower Performance Data – HB024	41		
Blower Performance Data – HB030	42		
Blower Performance Data – HB036	43		
Blower Performance Data – HB041	44		
Blower Performance Data – HB042	45		
Blower Performance Data – HB048	46		
Blower Performance Data – HB060	47		
Constant Volume ECM Control	48		
Wiring Diagram Matrix	49		
DIP Setting Table	50		
CXM Controls	51		
DXM2 Controls	52		
Safety Features – CXM and DXM2 Controls	57		
Unit Starting and Operating Conditions	59		
Piping System Cleaning and Flushing	60		
HB with Waterside Economizer Option	61		
Unit and System Checkout	63		
Unit Start-Up Procedure	64		
Unit Operating Conditions	66		
Preventive Maintenance	71		
Functional Troubleshooting	72		
Performance Troubleshooting	73		

Model Nomenclature – General Overview

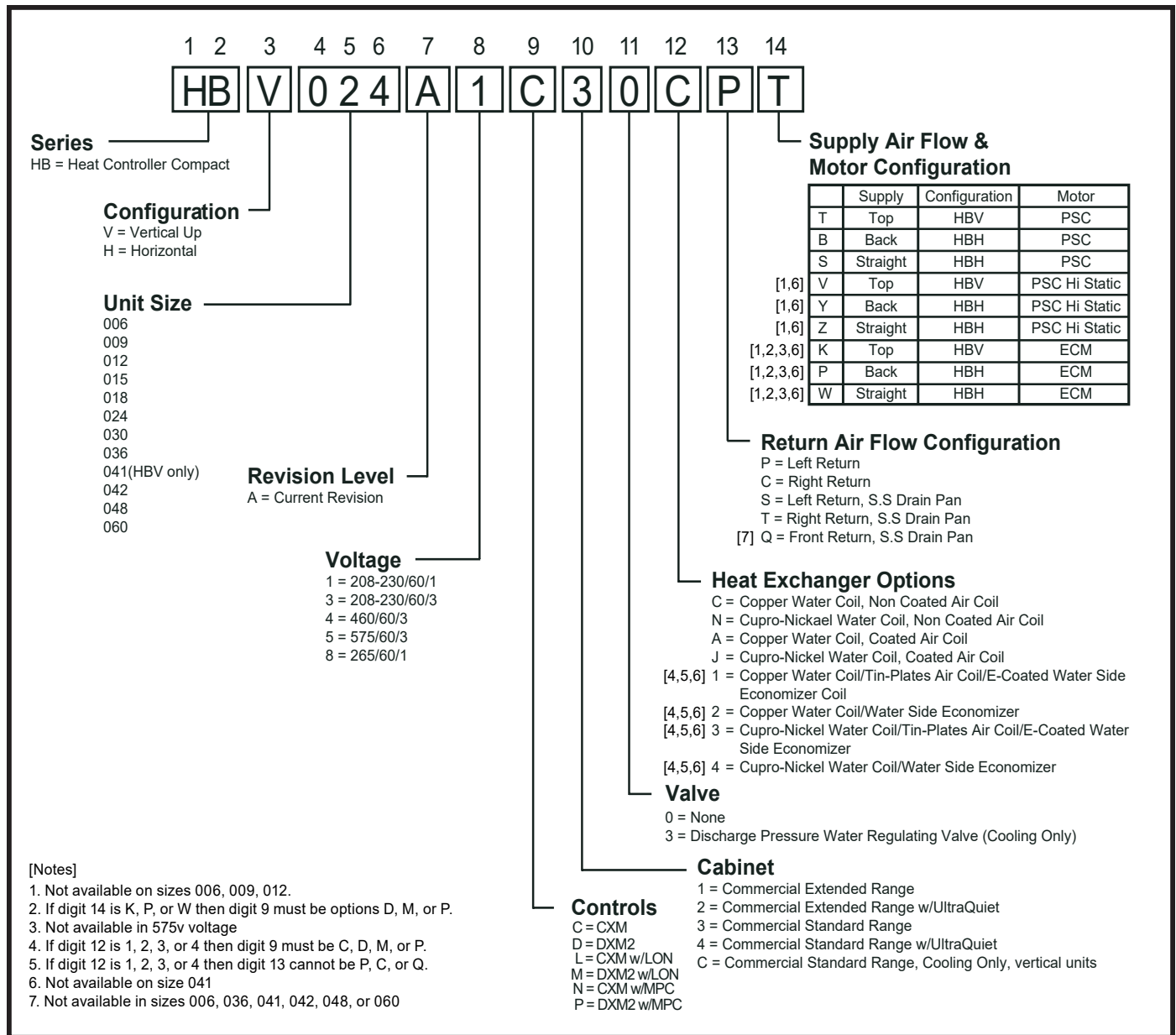

Note: Above model nomenclature is a general reference. Not all configurations are available on all models. Consult selection software for detailed information.

General Information

Safety

Warnings, cautions, and notices appear throughout this manual. Read these items carefully before attempting any installation, service, or troubleshooting of the equipment.

DANGER: Indicates an immediate hazardous situation, which if not avoided will result in death or serious injury. DANGER labels on unit access panels must be observed.

WARNING: Indicates a potentially hazardous situation, which if not avoided could result in death or serious injury.

CAUTION: Indicates a potentially hazardous situation or an unsafe practice, which if not avoided could result in minor or moderate injury or product or property damage.

NOTICE: Notification of installation, operation, or maintenance information, which is important, but which is not hazard-related.

WARNING!

WARNING! The Application and Service Manual should be read and understood before attempting to service refrigerant circuits with HFC-410A.

WARNING!

WARNING! To avoid the release of refrigerant into the atmosphere, the refrigerant circuit of this unit must be serviced only by technicians who meet local, state, and federal proficiency requirements.

CAUTION!

CAUTION! To avoid equipment damage, DO NOT use these units as a source of heating or cooling during the construction process. The mechanical components and filters can quickly become clogged with construction dirt and debris, which may cause system damage and void product warranty.

WARNING!

WARNING! The installation of water-source heat pumps and all associated components, parts, and accessories which make up the installation shall be in accordance with the regulations of ALL authorities having jurisdiction and MUST conform to all applicable codes. It is the responsibility of the installing contractor to determine and comply with ALL applicable codes and regulations.

WARNING!

WARNING! All refrigerant discharged from this unit must be recovered WITHOUT EXCEPTION. Technicians must follow industry accepted guidelines and all local, state, and federal statutes for the recovery and disposal of refrigerants. If a compressor is removed from this unit, refrigerant circuit oil will remain in the compressor. To avoid leakage of compressor oil, refrigerant lines of the compressor must be sealed after it is removed.

Inspection - Upon receipt of the equipment, carefully check the shipment against the bill of lading. Make sure all units have been received. Inspect the packaging of each unit, and inspect each unit for damage. Ensure that the carrier makes proper notation of any shortages or damage on all copies of the freight bill and completes a common carrier inspection report. Concealed damage not discovered during unloading must be reported to the carrier within 15 days of receipt of shipment. If not filed within 15 days, the freight company can deny the claim without recourse.

Note: It is the responsibility of the purchaser to file all necessary claims with the carrier. Notify your equipment supplier of all damage within fifteen (15) days of shipment.

Storage - Equipment should be stored in its original packaging in a clean, dry area. Store units in an upright position at all times. Stack units a maximum of 3 units high.

Unit Protection - Cover units on the job site with either the original packaging or an equivalent protective covering. Cap the open ends of pipes stored on the job site. In areas where painting, plastering, and/or spraying has not been completed, all due precautions must be taken to avoid physical damage to the units and contamination by foreign material. Physical damage and contamination may prevent proper start-up and may result in costly equipment clean-up.

General Information, Cont'd.

Examine all pipes, fittings, and valves before installing any of the system components. Remove any dirt or debris found in or on these components.

Pre-Installation - Installation, Operation, and Maintenance instructions are provided with each unit. Horizontal equipment is designed for installation above false ceiling or in a ceiling plenum. Other unit configurations are typically installed in a mechanical room. The installation site chosen should include adequate service clearance around the unit. Before unit start-up, read all manuals and become familiar with the unit and its operation. Thoroughly check the system before operation.

Prepare units for installation as follows:

1. Compare the electrical data on the unit nameplate with ordering and shipping information to verify that the correct unit has been shipped.
2. Keep the cabinet covered with the original packaging until installation is complete and all plastering, painting, etc. is finished.
3. Verify refrigerant tubing is free of kinks or dents and that it does not touch other unit components.
4. Inspect all electrical connections. Connections must be clean and tight at the terminals.
5. Remove any blower support packaging (water-to-air units only).
6. Some airflow patterns are field convertible (horizontal units only). Locate the airflow conversion section of this IOM.
7. Locate and verify any hot water generator (HWG), hanger, or other accessory kit located in the compressor section or blower section.

CAUTION!

CAUTION! All three phase scroll compressors must have direction of rotation verified at start-up. Verification is achieved by checking compressor Amp draw. Amp draw will be substantially lower compared to nameplate values. Additionally, reverse rotation results in an elevated sound level compared to correct rotation. Reverse rotation will result in compressor internal overload trip within several minutes. Verify compressor type before proceeding.

CAUTION!

CAUTION! DO NOT store or install units in corrosive environments or in locations subject to temperature or humidity extremes (e.g., attics, garages, rooftops, etc.). Corrosive conditions and high temperature or humidity can significantly reduce performance, reliability, and service life. Always move and store units in an upright position. Tilting units on their sides will cause equipment damage.

CAUTION!

CAUTION! CUT HAZARD - Failure to follow this caution may result in personal injury. Sheet metal parts may have sharp edges or burrs. Use care and wear appropriate protective clothing, safety glasses and gloves when handling parts and servicing heat pumps.

WARNING!

WARNING! This product can expose you to chemicals including formaldehyde, which is known to the state of California to cause cancer. For more information, go to www.P65Warnings.ca.gov.

WARNING!

WARNING! Polyolester Oil, commonly known as POE oil, is a synthetic oil used in many refrigeration systems including those with HFC-410A refrigerant. POE oil, if it ever comes in contact with the polymer drain pan, may cause the drain pan to leak. The polymer drain pan should never come in contact with POE oil as system failures and property damage may result.

Unit Physical Data

HB-Series (60 Hz)

HB Series	006	009	012	015	018	024	030	036	041	042	048	060
Compressor (1 Each)	Rotary						Scroll					
Factory Charge HFC-410A (oz)	19	20	23	35	43	40	48	50	70	70	74	82
ECM Fan Motor & Blower												
Blower Wheel Size (Dia x w)	N/A	N/A	N/A	9x7	9x7	9x7	9x7	9x8	N/A	9x8	10x10	12x10
PSC Fan Motor & Blower												
Fan Motor Type/Speeds	PSC/3	PSC/3	PSC-3	PSC/3	PSC/3	PSC/3	PSC/3	PSC/3	PSC/3	PSC/3	PSC/3	PSC/3
Blower Wheel Size (Dia x w)	5x5	5x5	6x5	8x7	8x7	9x7	9x7	9x8	9x8	9x8	10x10	12x10
Water Connection Size												
FPT	1/2"	1/2"	1/2"	1/2"	1/2"	3/4"	3/4"	3/4"	3/4"	3/4"	1"	1"
Coax Volume (gallons)	0.123	0.143	0.167	0.286	0.450	0.286	0.323	0.323	0.890	0.890	0.738	0.939
Vertical												
Air Coil Dimensions (H x W)	10x15	10x15	10x15	20x17.25	20x17.25	20x17.25	20x17.25	24x21.75	20x17.25	24x21.76	24x28.25	24x28.25
Filter Standard - 1" Throwaway	10x18	10x18	10x18	20x20	20x20	20x20	20x20	24x24	20x20	24x24	1-14x24, 1-18x24	1-14x24, 1-18x24
Weight - Operating (lbs.)	103	105	114	153	158	189	197	203	210	218	263	278
Weight - Packaged (lbs.)	113	115	124	158	163	194	202	209	217	224	270	285
Horizontal												
Air Coil Dimensions (H x W)	10x15	10x15	10x15	16x22	16x22	16x22	16x22	20x25	N/A	20x25	20x35	20x35
Filter Standard - 1" Throwaway	10x18	10x18	10x18	16x25	16x25	18x25	18x25	20x28 or 2-20x14	N/A	20x28 or 2-20x14	1-20x24, 1-20x14	1-20x24, 1-20x14
Weight - Operating (lbs.)	103	105	114	153	158	174	182	203	N/A	218	263	278
Weight - Packaged (lbs.)	113	115	124	158	163	179	187	209	N/A	224	270	285

Notes:

All units have TXV expansion device, and 1/2" & 3/4" electrical knockouts.
 FPT = Female Pipe Thread
 Condensate Drain Connection is rubber coupling that couples to 3/4" schedule 40/80 PVC.
 575 volt fan motors are two speed.

Unit Maximum Water Working Pressure	Max Pressure PSIG [kPa]
Base Unit	500 [3447]
WSE Option	300 [2068]

Horizontal Installation

Horizontal Unit Location

Units are not designed for outdoor installation. Locate the unit in an INDOOR area that allows enough space for service personnel to perform typical maintenance or repairs without removing unit from the ceiling. Horizontal units are typically installed above a false ceiling or in a ceiling plenum. Never install units in areas subject to freezing or where humidity levels could cause cabinet condensation (such as unconditioned spaces subject to 100% outside air). Consideration should be given to access for easy removal of the filter and access panels. Provide sufficient room to make water, electrical, and duct connection(s).

If the unit is located in a confined space, such as a closet, provisions must be made for return air to freely enter the space by means of a louvered door, etc. Any access panel screws that would be difficult to remove after the unit is installed should be removed prior to setting the unit. Refer to Figure 3 for an illustration of a typical installation. Refer to unit submittal data or engineering design guide for dimensional data.

Conform to the following guidelines when selecting unit location:

1. Provide a hinged access door in concealed-spline or plaster ceilings. Provide removable ceiling tiles in T-bar or lay-in ceilings. Refer to horizontal unit dimensions for specific series and model in unit submittal data. Size the access opening to accommodate the service technician during the removal or replacement of the compressor, control, or blower assembly.
2. Provide access to hanger brackets, water valves and fittings. Provide screwdriver clearance to access panels, discharge collars and all electrical connections.
3. DO NOT obstruct the space beneath the unit with piping, electrical cables and other items that prohibit future removal of components or the unit itself.
4. Use a manual portable jack/lift to lift and support the weight of the unit during installation and servicing.

The installation of water source heat pump units and all associated components, parts and accessories which make up the installation shall be in accordance with the regulations of ALL authorities having jurisdiction and MUST conform to all applicable codes. It is the responsibility of the installing contractor to determine and comply with ALL applicable codes and regulations.

Mounting Horizontal Units

Horizontal units have 4 hanger brackets partially attached at the factory, one at each corner. Enclosed within the unit there is a hanger kit hardware bag containing vibration isolation grommets, washers, screws and a hanger installation instruction page. One additional screw from the hardware bag must be added to each hanger bracket before unit installation. Tighten each screw to 75 in-lbs (8.5 Nm). See Figure 1. Refer to the hanger installation instruction page contained in the hardware bag for details of final hanger bracket attachment and unit suspension. See Figure 1a.

Use four (4) field supplied threaded rods and factory provided vibration isolators to suspend the unit. Safely lift the unit into position supporting the bottom of the unit. Ensure the top of the unit is not in contact with any external objects. Connect the top end of the 4 all-thread rods, slide rods through the brackets and grommet then assemble washers and double nuts at each rod. Ensure that the unit is approximately level and that the threaded rod extends past the nuts.

Pitch the unit toward the drain as shown in Figure 2 to improve the condensate drainage. On small units (less than 2.5 tons/8.8kW) ensure that unit pitch does not cause condensate leaks inside the cabinet.

Figure 1: Hanger Bracket

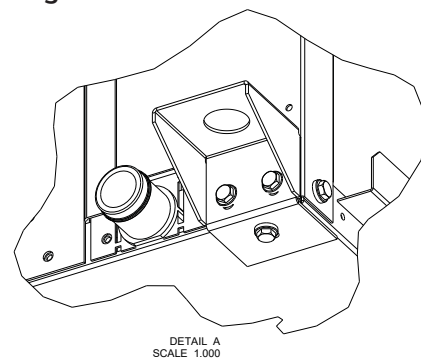
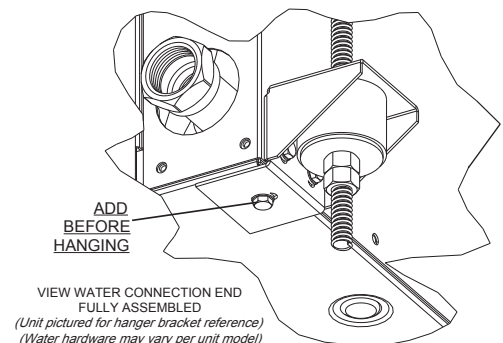

Figure 1a:



Horizontal Installation, Cont'd.

Figure 2: Horizontal Unit Pitch

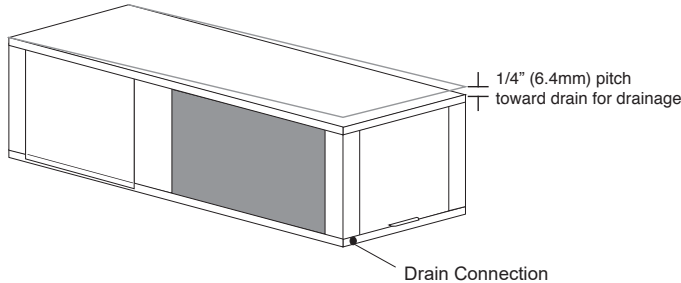
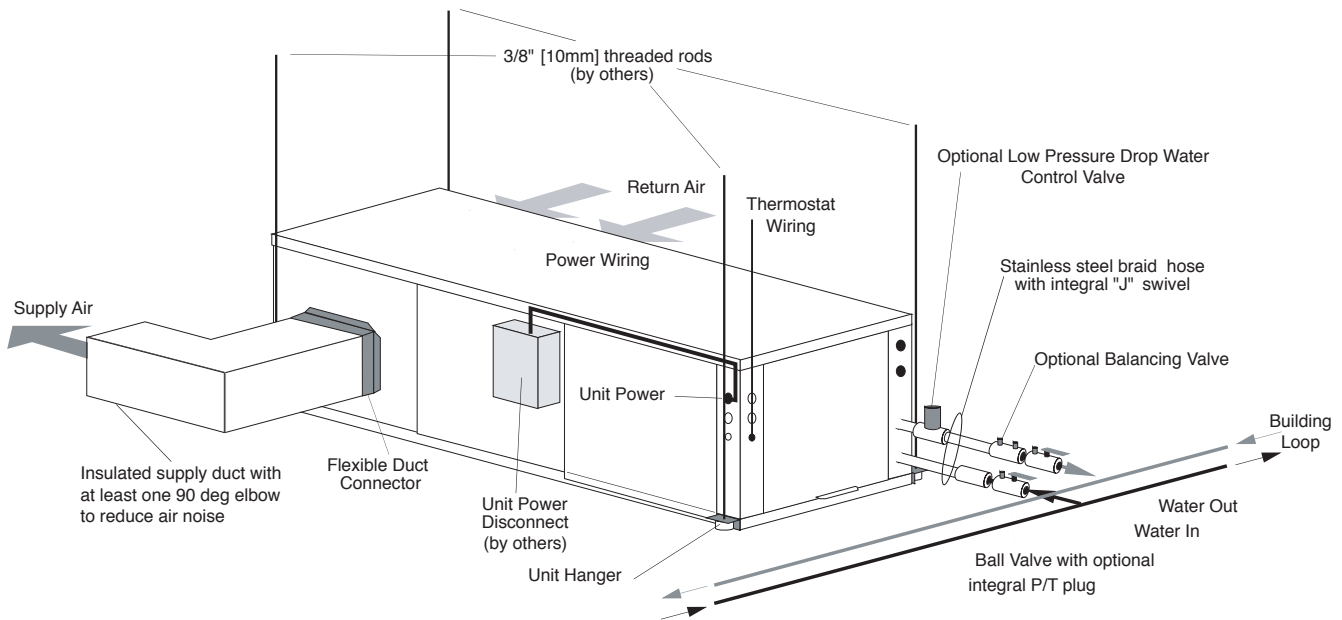

Figure 3: Typical Horizontal Unit Installation



Air Coil - To obtain maximum performance, the air coil should be cleaned before start-up. A 10% solution of dishwasher detergent and water is recommended for both sides of the coil. A thorough water rinse should follow. **UV based anti-bacterial systems may damage e-coated air coils.**

Notice! Installation Note - Ducted Return: Many horizontal WSHPs are installed in a return air ceiling plenum application (above ceiling). Vertical WSHPs are commonly installed in a mechanical room with free return (e.g. louvered door). Therefore, filter rails are the industry standard and are included on our commercial heat pumps for the purposes of holding the filter only. For ducted return applications, the filter rail must be removed and replaced with a duct flange or filter frame. Canvas or flexible connectors should also be used to minimize vibration between the unit and ductwork.

Horizontal Installation – Field Conversion of Air Discharge

Overview - Horizontal units can be field converted between side (straight) and back (end) discharge using the instructions below.

Note: It is not possible to field convert return air between left or right return models due to the necessity of refrigeration copper piping changes.

Preparation - It is best to field convert the unit on the ground before hanging. If the unit is already hung it should be taken down for the field conversion.

Side to Back Discharge Conversion

1. Place unit in well lit area. Remove the screws as shown in Figure 4 to free top panel and discharge panel.
2. Lift out the access panel and set aside. Lift and rotate the discharge panel to the other position as shown, being careful with the blower wiring.
3. Check blower wire routing and connections for tension or contact with sheet metal edges. Re-route if necessary.
4. Check refrigerant tubing for contact with other components.
5. Reinstall top panel and screws noting that the location for some screws will have changed.
6. Manually spin the fan wheel to ensure that the wheel is not rubbing or obstructed.
7. Replace access panels.

Back to Side Discharge Conversion - If the discharge is changed from back to side, use above instruction noting that illustrations will be reversed.

Left vs. Right Return - It is not possible to field convert return air between left or right return models due to the necessity of refrigeration copper piping changes. However, the conversion process of side to back or back to side discharge for either right or left return configuration is the same. In some cases, it may be possible to rotate the entire unit 180 degrees if the return air connection needs to be on the opposite side. **Note that rotating the unit will move the piping to the other end of the unit.**

Figure 4: Left Return Side to Back

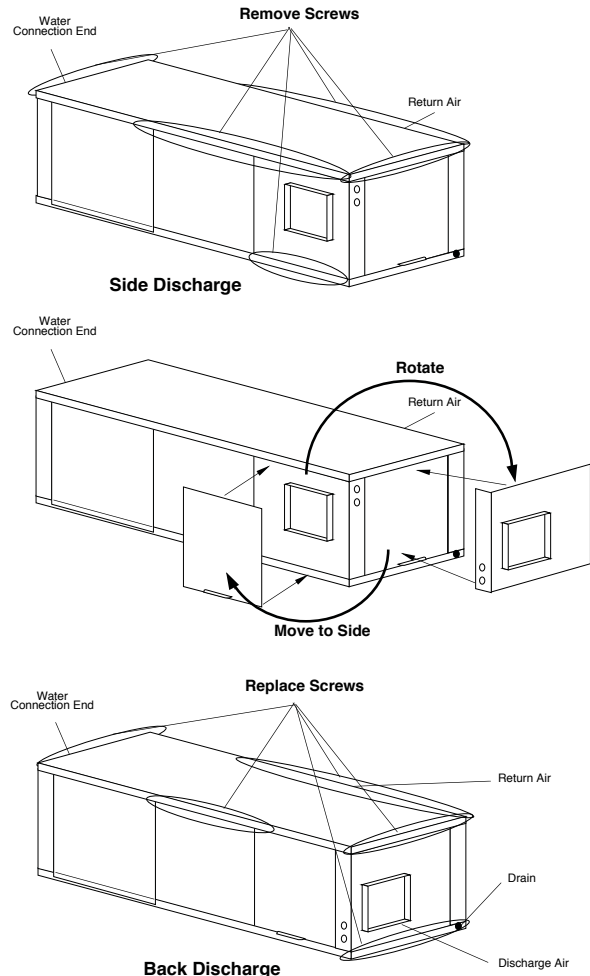
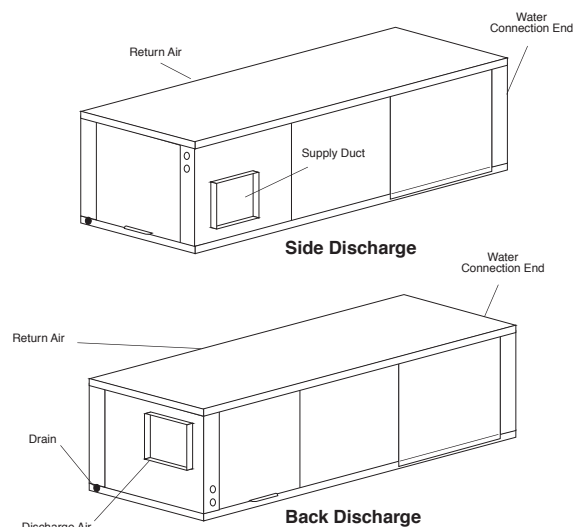

Figure 5: Right Return Side to Back



Horizontal Installation, Cont'd.

Condensate Piping - Horizontal Units - A condensate drain line must be installed and pitched away for the unit to allow for proper drainage. This connection must meet all local plumbing/building codes.

Pitch the unit toward the drain as shown in Figure 2 to improve the condensate drainage. On small units (less than 2.5 tons/8.8 kW), ensure that unit pitch does not cause condensate leaks inside the cabinet.

Install condensate trap at each unit with the top of the trap positioned below the unit condensate drain connection as shown in Figure 6. Design the depth of the trap (water-seal) based upon the amount of ESP capability of the blower (where 2 inches [51mm] of ESP capability requires 2 inches [51mm] of trap depth). As a general rule, 1-1/2 inch [38mm] trap depth is the minimum.

Models with Water Side Economizer (Model Digit 12 is 1-4) Must trap WSE same as unit, can join together after vent.

Each unit must be installed with its own individual trap and connection to the condensate line (main) or riser. Provide a means to flush or blow out the condensate line. DO NOT install units with a common trap and/or vent.

Always vent the condensate line when dirt or air can collect in the line or a long horizontal drain line is required. Also vent when large units are working against higher external static pressure than other units connected to the same condensate main since this may cause poor drainage for all units on the line. **WHEN A VENT IS INSTALLED IN THE DRAIN LINE, IT MUST BE LOCATED AFTER THE TRAP IN THE DIRECTION OF THE CONDENSATE FLOW.**

Condensate drain connection is a rubber coupling that couples to 3/4" schedule 40/80 PVC. Use hose clamps to secure the pipe inside the coupling. If the connection is not secure, the connection may leak.

Instructions for coupling the condensate drain to the trap are included in the bag that includes the coupling and hose clamps.

Duct System Installation - Proper duct sizing and design is critical to the performance of the unit. The duct system should be designed to allow adequate and even airflow through the unit during operation. Air flow through the unit **MUST** be at or above the minimum stated airflow for the unit to avoid equipment damage. Duct systems should be designed for quiet operation. Refer to Figure 3 for horizontal duct system details or Figure 8 for vertical duct system details. A flexible connector is recommended for both discharge and return air duct connections on metal duct systems to eliminate the transfer of vibration to the duct system. To maximize sound attenuation of the unit blower, the supply and return plenums should include internal fiberglass duct liner or be constructed from ductboard for the first few feet. Application of the unit to uninsulated ductwork in an unconditioned space is not recommended, as the unit's performance may be adversely affected.

At least one 90° elbow should be included in the supply duct to reduce air noise. If air noise or excessive air flow is a problem, the blower speed can be changed. For airflow charts, consult submittal data for the series and model of the specific unit.

If the unit is connected to existing ductwork, a previous check should have been made to ensure that the ductwork has the capacity to handle the airflow required for the unit. If ducting is too small, as in the replacement of a heating only system, larger ductwork should be installed. All existing ductwork should be checked for leaks and repaired as necessary.

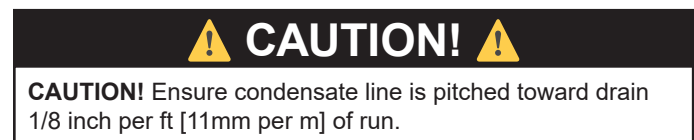
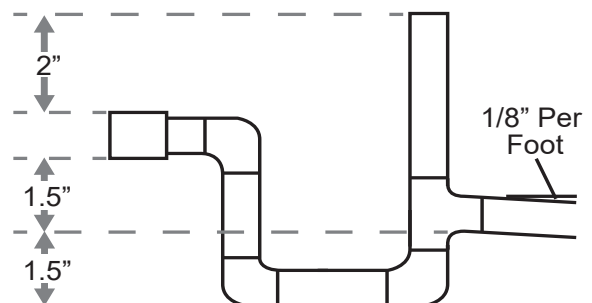

Figure 6: Horizontal Condensate Connection



Vertical Installation

Vertical Unit Location - Units are not designed for outdoor installation. Locate the unit in an INDOOR area that allows enough space for service personnel to perform typical maintenance or repairs without removing unit from the mechanical room/closet. Vertical units are typically installed in a mechanical room or closet. Never install units in areas subject to freezing or where humidity levels could cause cabinet condensation (such as unconditioned spaces subject to 100% outside air). Consideration should be given to access for easy removal of the filter and access panels. Provide sufficient room to make water, electrical, and duct connection(s).

If the unit is located in a confined space, such as a closet, provisions must be made for return air to freely enter the space by means of a louvered door, etc. Any access panel screws that would be difficult to remove after the unit is installed should be removed prior to setting the unit. Refer to Figures 7 and 8 for typical installation illustrations. Refer to unit submittal data or engineering design guide for dimensional data.

1. Install the unit on a piece of rubber, neoprene or other mounting pad material for sound isolation. The pad should be at least 3/8" [10mm] to 1/2" [13mm] in thickness. Extend the pad beyond all four edges of the unit.
2. Provide adequate clearance for filter replacement and drain pan cleaning. Do not block filter access with piping, conduit or other materials. Refer to unit submittal data or engineering design guide for dimensional data.
3. Provide access for fan and fan motor maintenance and for servicing the compressor and coils without removing the unit.
4. Provide an unobstructed path to the unit within the closet or mechanical room. Space should be sufficient to allow removal of the unit, if necessary.
5. In limited side access installations, pre-removal of the control box side mounting screws will allow control box removal for future servicing.
6. Provide access to water valves and fittings and screwdriver access to the unit side panels, discharge collar and all electrical connections.

Figure 7: Vertical Unit Mounting

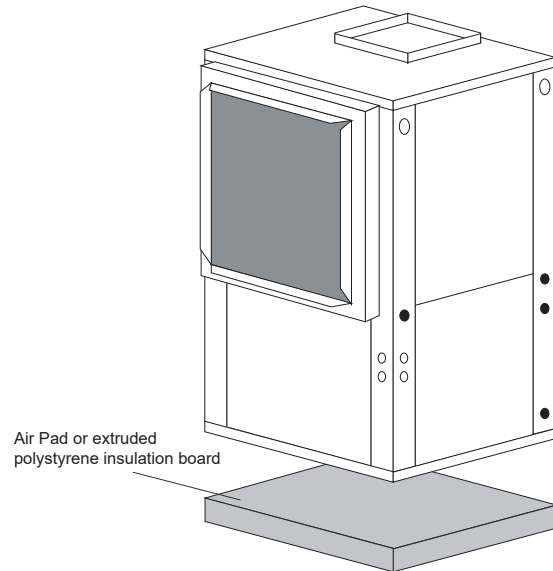
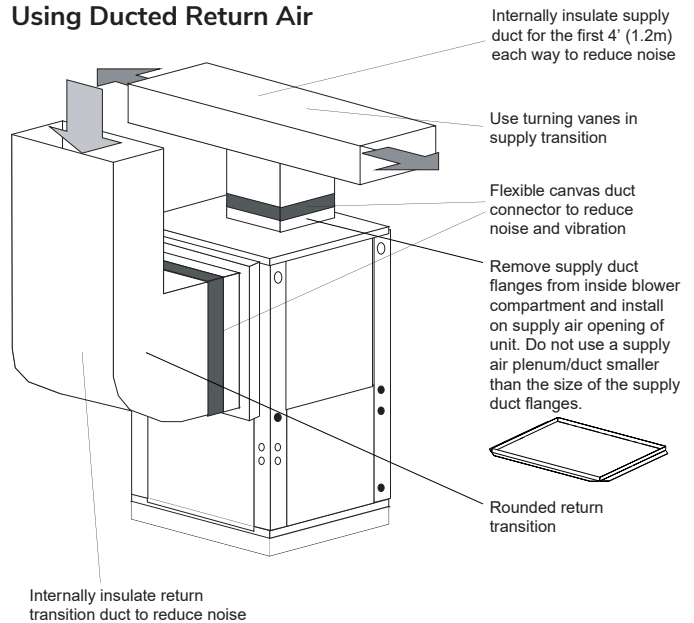

Figure 8: Typical Vertical Unit Installation Using Ducted Return Air



Notice! Installation Note - Ducted Return: Many horizontal WSHPs are installed in a return air ceiling plenum application (above ceiling). Vertical WSHPs are commonly installed in a mechanical room with free return (e.g. louvered door). Therefore, filter rails are the industry standard and are included on our commercial heat pumps for the purposes of holding the filter only. For ducted return applications, the filter rail must be removed and replaced with a duct flange or filter frame. Canvas or flexible connectors should also be used to minimize vibration between the unit and ductwork.

Vertical Installation, Cont'd.

Sound Attenuation for Vertical Units - Sound attenuation is achieved by enclosing the unit within a small mechanical room or a closet. Additional measures for sound control include the following:

1. Mount the unit so that the return air inlet is 90° to the return air grille. Refer to Figure 9. Install a sound baffle as illustrated to reduce line-of-sight sound transmitted through return air grilles.
2. Mount the unit on a rubber or neoprene isolation pad to minimize vibration transmission to the building structure.

Figure 9: Vertical Sound Attenuation

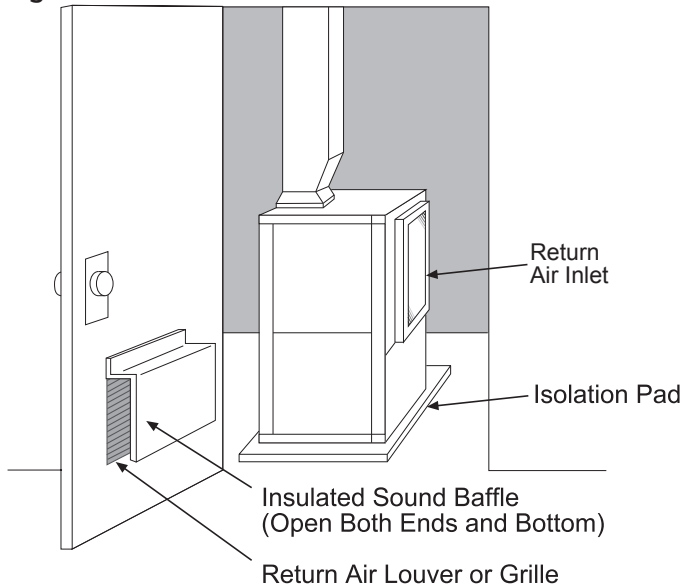

Notice! Units with clear plastic drain lines should have regular maintenance (as required) to avoid buildup of debris, especially in new construction.

Condensate Piping for Vertical Units - A condensate line must be installed and pitched away from the unit to allow for proper drainage. This connection must meet all local plumbing/building codes.

Install condensate trap at each unit with the top of the trap positioned below the unit condensate drain connection as shown in Figure 10. Design the depth of the trap (water-seal) based upon the amount of ESP capability of the blower (where 2 inches [51mm] of ESP capability requires 2 inches [51mm] of trap depth). As a general rule, 1-1/2 inch [38mm] trap depth is the minimum.

Always vent the condensate line when dirt or air can collect in the line or a long horizontal drain line is required. Also vent when large units are working against higher external static pressure than other units connected to the same condensate main since this may cause poor drainage for all units on the line. **WHEN A VENT IS INSTALLED IN THE DRAIN LINE, IT MUST BE LOCATED AFTER THE TRAP IN THE DIRECTION OF THE CONDENSATE FLOW.**

Each unit must be installed with its own individual vent (where necessary) and a means to flush or blow out the condensate drain line. Do not install units with a common trap and/or vent.

Condensate drain connection is a rubber coupling that couples to 3/4" schedule 40/80 PVC. Use hose clamps to secure the pipe inside the coupling. If the connection is not secure, the connection may leak.

Instructions for coupling the condensate drain to the trap are included in the bag that includes the coupling and hose clamps.

Figure 10: Vertical Condensate Drain

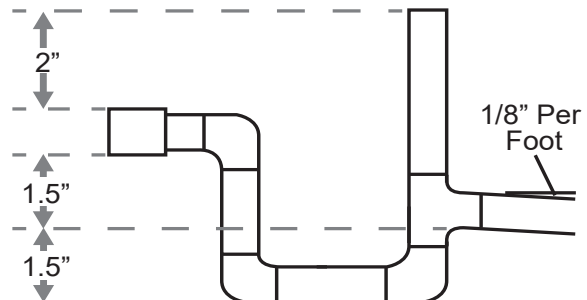

Piping Installation

Installation of Supply and Return Piping

Follow these piping guidelines.

1. Install a drain valve at the base of each supply and return riser to facilitate system flushing.
2. Install shut-off / balancing valves and unions at each unit to permit unit removal for servicing.
3. Place strainers at the inlet of each system circulating pump.
4. Select the proper hose length to allow slack between connection points. Hoses may vary in length by +2% to -4% under pressure.
5. Refer to Table 1. Do not exceed the minimum bend radius for the hose selected. Exceeding the minimum bend radius may cause the hose to collapse, which reduces water flow rate. Install an angle adapter to avoid sharp bends in the hose when the radius falls below the required minimum.

Insulation is not required on loop water piping except where the piping runs through unheated areas, outside the building or when the loop water temperature is below the minimum expected dew point of the pipe ambient conditions. Insulation is required if loop water temperature drops below the dew point (insulation is required for ground loop applications in most climates).

Pipe joint compound is not necessary when Teflon® thread tape is pre-applied to hose assemblies or when flared-end connections are used. If pipe joint compound is preferred, use compound only in small amounts on the external pipe threads of the fitting adapters. Prevent sealant from reaching the flared surfaces of the joint.

Note: When antifreeze is used in the loop, ensure that it is compatible with the Teflon® tape or pipe joint compound that is applied.

Maximum allowable torque for brass fittings is 30 ft-lbs [41 N-m]. If a torque wrench is not available, tighten finger-tight plus one quarter turn. Tighten steel fittings as necessary.

Models with Waterside Economizer Option (Model Digit 12 is 1-4) - Field fabricate water piping to connect WSE out to unit in. Allow room to remove front access panel and service unit. Insulate pipe. Hoses are not recommended due to high pressure drop.

Optional pressure-rated hose assemblies designed specifically for use with our units are available. Similar hoses can be obtained from alternate suppliers. Supply and return hoses are fitted with swivel-joint fittings at one

end to prevent kinking during installation. Refer to Figure 11 for an illustration of a typical supply/return hose kit. Adapters secure hose assemblies to the unit and risers. Install hose assemblies properly and check regularly to avoid system failure and reduced service life.

A backup wrench is required when tightening water connections on HB Series units to prevent water line damage.

! WARNING! !

WARNING! Polyolester Oil, commonly known as POE oil, is a synthetic oil used in many refrigeration systems including those with HFC-410A refrigerant. POE oil, if it ever comes in contact with PVC or CPVC piping, may cause failure of the PVC/CPVC. PVC/CPVC piping should never be used as supply or return water piping with water source heat pump products containing HFC-410A as system failures and property damage may result.

! CAUTION! !

CAUTION! Corrosive system water requires corrosion resistant fittings and hoses, and may require water treatment.

! CAUTION! !

CAUTION! Do not bend or kink supply lines or hoses.

! CAUTION! !

CAUTION! Piping must comply with all applicable codes.

Table 1: Metal Hose Minimum Bend Radii

Hose Diameter	Minimum Bend Radii
1/2" [12.7mm]	2-1/2" [6.4cm]
3/4" [19.1mm]	4" [10.2cm]
1" [25.4mm]	5-1/2" [14cm]
1-1/4" [31.8mm]	6-3/4" [17.1cm]

NOTICE! Do not allow hoses to rest against structural building components. Compressor vibration may be transmitted through the hoses to the structure, causing unnecessary noise complaints.

Figure 11: Supply/Return Hose Kit

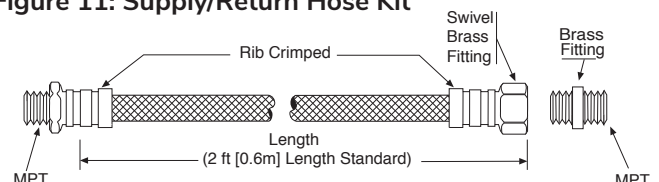

Water-Loop Heat Pump Applications

Commercial Water Loop Applications

Commercial systems typically include a number of units connected to a common piping system. Any unit plumbing maintenance work can introduce air into the piping system; therefore air elimination equipment is a major portion of the mechanical room plumbing. Consideration should be given to insulating the piping surfaces to avoid condensation. The manufacturer recommends unit insulation any time the water temperature is expected to be below 60°F (15.6°C). Metal to plastic threaded joints should never be used due to their tendency to leak over time.

Teflon® tape thread sealant is recommended to minimize internal fouling of the heat exchanger. Do not over tighten connections and route piping so as not to interfere with service or maintenance access. Hose kits are available from the manufacturer in different configurations as shown in Figure 12 for connection between the unit and the piping system. Depending upon selection, hose kits may include shut off valves, P/T plugs for performance measurement, high pressure stainless steel braided hose, “Y” type strainer with blow down valve, and/or “J” type swivel connection.

Balancing valves and an external low pressure drop solenoid valve for use in variable speed pumping systems may also be included in the hose kit.

The piping system should be flushed to remove dirt, piping chips, and other foreign material prior to operation (see “Piping System Cleaning and Flushing Procedures” in this manual). The flow rate is usually set between 2.25 and 3.5 gpm per ton [2.9 and 4.5 l/m per kW] of cooling capacity. The manufacturer recommends 3 gpm per ton [3.9 l/m per kW] for most applications of water loop heat pumps. To ensure proper maintenance and servicing, P/T ports are imperative for temperature and flow verification, as well as performance checks.

Water loop heat pump (cooling tower/boiler) systems typically utilize a common loop, maintained between 60 - 90°F [16 - 32°C]. The use of a closed circuit evaporative cooling tower with a secondary heat exchanger between the tower and the water loop is recommended. If an open type cooling tower is used continuously, chemical treatment and filtering will be necessary.

Figure 12: Typical Water-Loop Application

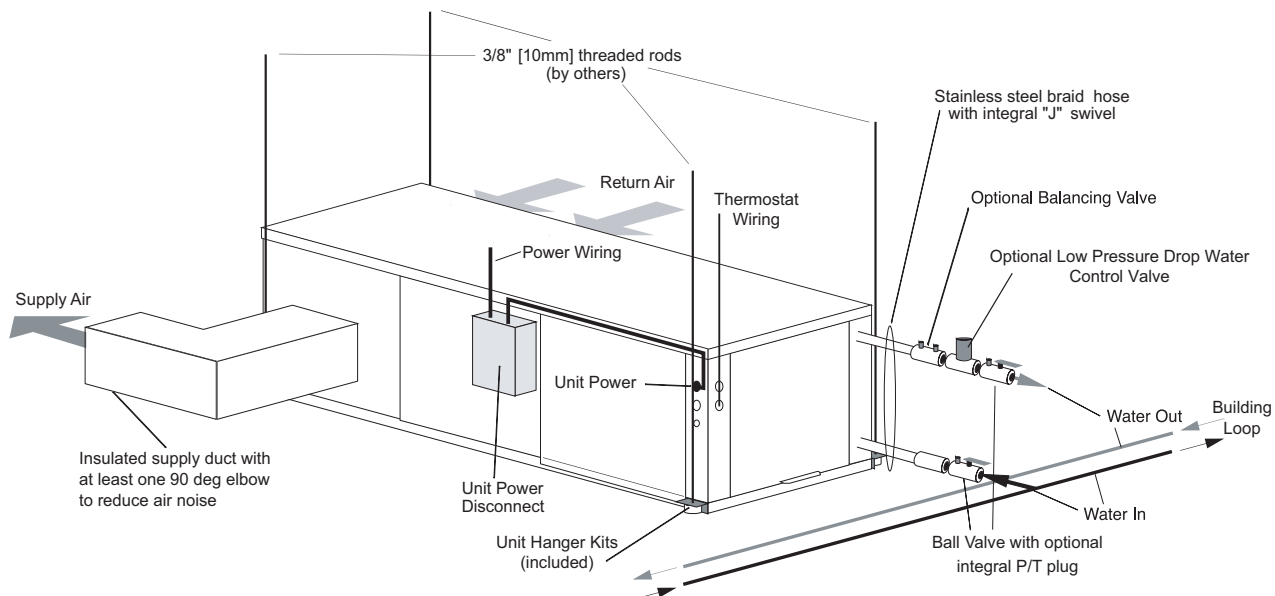

Low Water Temperature Cutout Setting - CXM Control
When antifreeze is selected, the LT1 jumper (JW3) should be clipped to select the low temperature (antifreeze 10.0°F [-12.2°C]) setpoint and avoid nuisance faults (see “Low

Water Temperature Cutout Selection” in this manual). **Note: Low water temperature operation requires extended range equipment.**

Ground-Loop Heat Pump Applications

⚠ CAUTION! ⚠

CAUTION! The following instructions represent industry accepted installation practices for closed loop earth coupled heat pump systems. Instructions are provided to assist the contractor in installing trouble free ground loops. These instructions are recommendations only. State/provincial and local codes **MUST** be followed and installation **MUST** conform to **ALL** applicable codes. It is the responsibility of the installing contractor to determine and comply with **ALL** applicable codes and regulations.

⚠ CAUTION! ⚠

CAUTION! Ground loop applications require extended range equipment and optional refrigerant/water circuit insulation.

Pre-Installation

Prior to installation, locate and mark all existing underground utilities, piping, etc. Install loops for new construction before sidewalks, patios, driveways, and other construction has begun. During construction, accurately mark all ground loop piping on the plot plan as an aid in avoiding potential future damage to the installation.

Piping Installation

The typical closed loop ground source system is shown in Figure 13. All earth loop piping materials should be limited to polyethylene fusion only for in-ground sections of the loop. Galvanized or steel fittings should not be used at any time due to their tendency to corrode. All plastic to metal threaded fittings should be avoided due to their potential to leak in earth coupled applications. A flanged fitting should be substituted. P/T plugs should be used so that flow can be measured using the pressure drop of the unit heat exchanger.

Earth loop temperatures can range between 25 and 110°F [-4 to 43°C]. Flow rates between 2.25 and 3 gpm [2.41 to 3.23 l/m per kW] of cooling capacity is recommended in these applications.

Test individual horizontal loop circuits before backfilling. Test vertical U-bends and pond loop assemblies prior to installation. Pressures of at least 100 psi [689 kPa] should be used when testing. Do not exceed the pipe pressure rating. Test entire system when all loops are assembled.

Flushing the Earth Loop

Upon completion of system installation and testing, flush the system to remove all foreign objects and purge to remove all air.

Antifreeze

In areas where minimum entering loop temperatures drop below 40°F [5°C] or where piping will be routed through areas subject to freezing, antifreeze is required. Alcohols and glycols are commonly used as antifreeze; however your local sales office should be consulted to determine the antifreeze best suited to your area. Freeze protection should be maintained to 15°F [9°C] below the lowest expected entering loop temperature. For example, if 30°F [-1°C] is the minimum expected entering loop temperature, the leaving loop temperature would be 22 to 25°F [-6 to -4°C] and freeze protection should be at 15°F [-10°C].

Calculation is as follows:

$$30^{\circ}\text{F} - 15^{\circ}\text{F} = 15^{\circ}\text{F} \quad [-1^{\circ}\text{C} - 9^{\circ}\text{C} = -10^{\circ}\text{C}]$$

All alcohols should be premixed and pumped from a reservoir outside of the building when possible or introduced under the water level to prevent fumes. Calculate the total volume of fluid in the piping system. Then use the percentage by volume shown in table 2 for the amount of antifreeze needed. Antifreeze concentration should be checked from a well mixed sample using a hydrometer to measure specific gravity.

Low Water Temperature Cutout Setting - CXM Control

When antifreeze is selected, the LT1 jumper (JW3) should be clipped to select the low temperature (antifreeze 10.0°F [-12.2°C]) setpoint and avoid nuisance faults (see “Low Water Temperature Cutout Selection” in this manual). **Note: Low water temperature operation requires extended range equipment.**

Table 2: Antifreeze Percentages by Volume

Type	Minimum Temperature for Low Temperature Protection			
	10°F [-12.2°C]	15°F [-9.4°C]	20°F [-6.7°C]	25°F [-3.9°C]
Methanol	25%	21%	16%	10%
100% USP food grade Propylene Glycol	38%	25%	22%	15%
Ethanol*	29%	25%	20%	14%

* Must not be denatured with any petroleum based product

Ground-Loop Heat Pump Applications, Cont'd.

Figure 13: Typical Ground-Loop Application

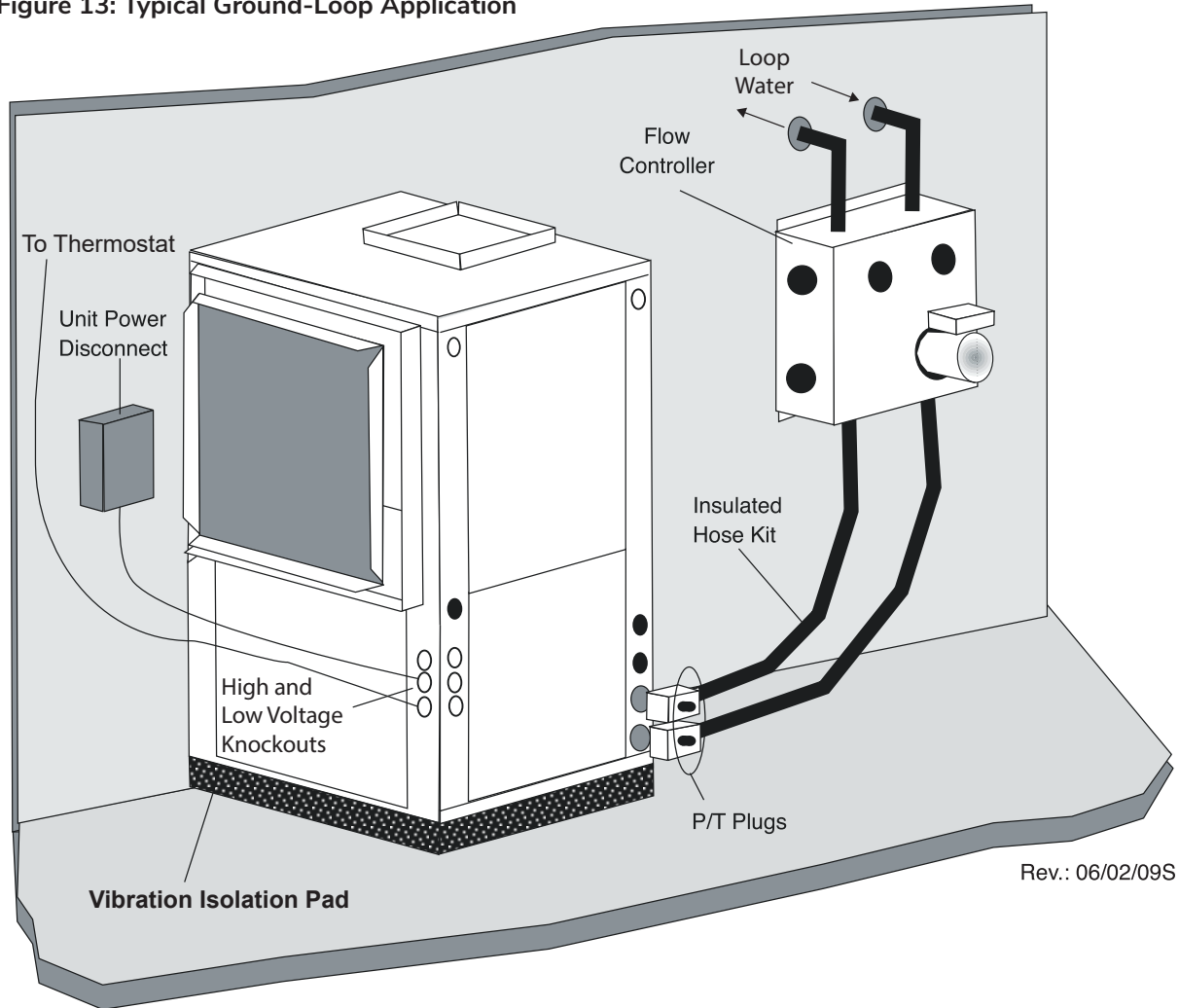

Ground-Water Heat Pump Applications

Open Loop - Ground Water Systems - Typical open loop piping is shown in Figure 14. Shut off valves should be included for ease of servicing. Boiler drains or other valves should be “tee'd” into the lines to allow acid flushing of the heat exchanger. Shut off valves should be positioned to allow flow through the coax via the boiler drains without allowing flow into the piping system. P/T plugs should be used so that pressure drop and temperature can be measured. Supply and return water piping materials should be limited to copper, PE, or similar material. PVC or CPVC should never be used as they are incompatible with the POE oils used in HFC-410A products and piping system failure and property damage may result.

WARNING!

WARNING! Polyolester Oil, commonly known as POE oil, is a synthetic oil used in many refrigeration systems including those with HFC-410A refrigerant. POE oil, if it ever comes in contact with PVC or CPVC piping, may cause failure of the PVC/CPVC. PVC/CPVC piping should never be used as supply or return water piping with water source heat pump products containing HFC-410A as system failures and property damage may result.

Water quantity should be plentiful and of good quality. Consult table 3 for water quality guidelines. The unit can be ordered with either a copper or cupro-nickel water heat exchanger. Consult Table 3 for recommendations. Copper is recommended for closed loop systems and open loop ground water systems that are not high in mineral content or corrosiveness. In conditions anticipating heavy scale formation or in brackish water, a cupro-nickel heat exchanger is recommended. In ground water situations where scaling could be heavy or where biological growth such as iron bacteria will be present, an open loop system is not recommended. Heat exchanger coils may over time lose heat exchange capabilities due to build up of mineral deposits. Heat exchangers must only be serviced by a qualified technician, as acid and special pumping equipment is required. Desuperheater coils can likewise become scaled and possibly plugged. In areas with extremely hard water, the owner should be informed that the heat exchanger may require occasional acid flushing. In some cases, the desuperheater option should not be recommended due to hard water conditions and additional maintenance required.

Water Quality Standards - Table 3 should be consulted for water quality requirements. Scaling potential should be assessed using the pH/Calcium hardness method. If the pH <7.5 and the calcium hardness is less than 100 ppm, scaling potential is low. If this method yields numbers out of range of those listed, the Ryznar Stability and Langelier Saturation indices should be calculated. Use the appropriate scaling surface temperature for the application, 150°F [66°C] for direct use (well water/open loop); 90°F [32°F] for indirect use. A monitoring plan should be implemented in these probable scaling situations. Other water quality issues such as iron fouling, corrosion prevention and erosion and clogging should be referenced in Table 3.

Expansion Tank and Pump - Use a closed, bladder-type expansion tank to minimize mineral formation due to air exposure. The expansion tank should be sized to provide at least one minute continuous run time of the pump using its drawdown capacity rating to prevent pump short cycling. Discharge water from the unit is not contaminated in any manner and can be disposed of in various ways, depending on local building codes (e.g. recharge well, storm sewer, drain field, adjacent stream or pond, etc.). Most local codes forbid the use of sanitary sewer for disposal. Consult your local building and zoning department to assure compliance in your area.

Water Control Valve - Note the placement of the water control valve in Figure 14. Always maintain water pressure in the heat exchanger by placing the water control valve(s) on the discharge line to prevent mineral precipitation during the off-cycle. Pilot operated slow closing valves are recommended to reduce water hammer. If water hammer persists, a mini-expansion tank can be mounted on the piping to help absorb the excess hammer shock. Ensure that the total 'VA' draw of the valve can be supplied by the unit transformer. For instance, a slow closing valve can draw up to 35VA. This can overload smaller 40 or 50 VA transformers depending on the other controls in the circuit. A typical pilot operated solenoid valve draws approximately 15VA (see Figure 19). Note the special wiring diagrams for slow closing valves (Figures 20 & 21).

Ground-Water Heat Pump Applications, Cont'd.

Flow Regulation - Flow regulation can be accomplished by two methods. One method of flow regulation involves simply adjusting the ball valve or water control valve on the discharge line. Measure the pressure drop through the unit heat exchanger, and determine flow rate from Tables 8a through 8e. Since the pressure is constantly varying, two pressure gauges may be needed. Adjust the valve until the desired flow of 1.5 to 2 gpm per ton [2.0 to 2.6 l/m per kW] is achieved. A second method of flow control requires a flow control device mounted on the outlet of the water control valve. The device is typically a brass fitting with an orifice of rubber or plastic material that is designed to allow a specified flow rate. On occasion, flow control devices may produce velocity noise that can be

reduced by applying some back pressure from the ball valve located on the discharge line. Slightly closing the valve will spread the pressure drop over both devices, lessening the velocity noise.

Note: When EWT is below 50°F [10°C], 2 gpm per ton (2.6 l/m per kW) is required.

Water Coil Low Temperature Limit Setting - For all open loop systems the 30°F [-1.1°C] FP1 setting (factory setting-water) should be used to avoid freeze damage to the unit. See "Low Water Temperature Cutout Selection" in this manual for details on the low limit setting.

Figure 14: Typical Open Loop/Well Application

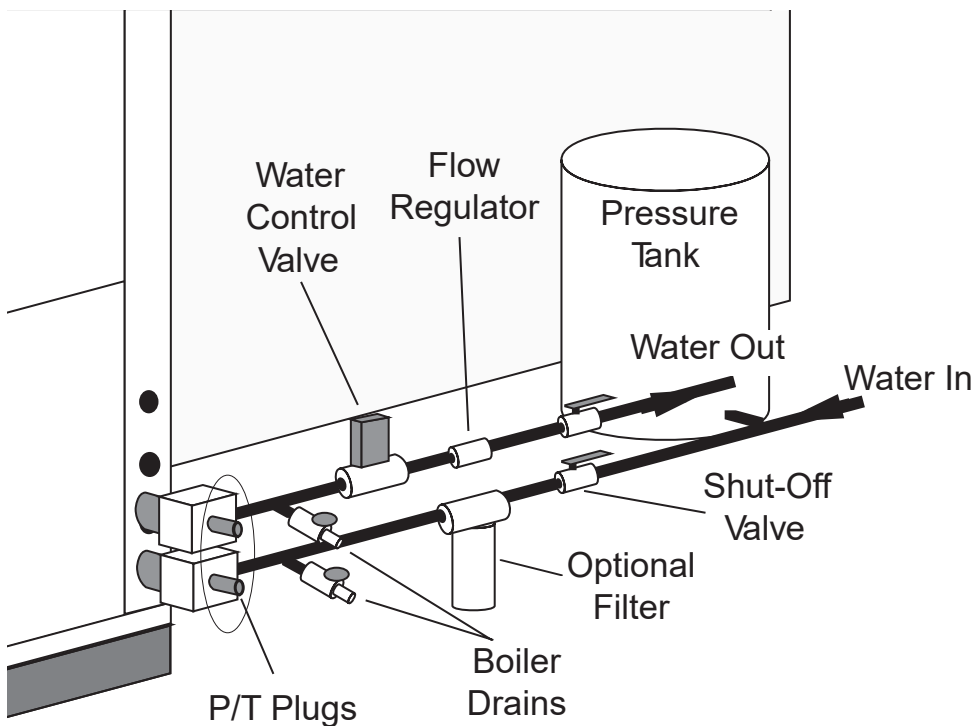

Water Quality Standards

Table 3: Water Quality Standards

Water Quality Parameter	HX Material	Closed Recirculating	Open Loop and Recirculating Well		
Scaling Potential - Primary Measurement					
Above the given limits, scaling is likely to occur. Scaling indexes should be calculated using the limits below					
pH/Calcium Hardness Method	All	-	pH < 7.5 and Ca Hardness <100ppm		
Index Limits for Probable Scaling Situations - (Operation outside these limits is not recommended)					
Scaling indexes should be calculated at 66°C for direct use and HWG applications, and at 32°C for indirect HX use. A monitoring plan should be implemented.					
Ryznar Stability Index	All	-	6.0 - 7.5 If >7.5 minimize steel pipe use.		
Langelier Saturation Index	All	-	-0.5 to +0.5 If <-0.5 minimize steel pipe use. Based upon 66°C HWG and Direct well, 29°C Indirect Well HX		
Iron Fouling					
Iron Fe ²⁺ (Ferrous) (Bacterial Iron potential)	All	-	<0.2 ppm (Ferrous) If Fe ²⁺ (ferrous)>0.2 ppm with pH 6 - 8, O ₂ <5 ppm check for iron bacteria.		
Iron Fouling	All	-	<0.5 ppm of Oxygen Above this level deposition will occur.		
Corrosion Prevention					
pH	All	6 - 8.5 Monitor/treat as needed	6 - 8.5 Minimize steel pipe below 7 and no open tanks with pH <8		
Hydrogen Sulfide (H ₂ S)	All	-	<0.5 ppm At H ₂ S>0.2 ppm, avoid use of copper and copper nickel piping or HX's. Rotten egg smell appears at 0.5 ppm level. Copper alloy (bronze or brass) cast components are OK to <0.5 ppm.		
Ammonia ion as hydroxide, chloride, nitrate and sulfate compounds	All	-	<0.5 ppm		
Maximum Chloride Levels			Maximum Allowable at maximum water temperature.		
			10°C	24°C	38°C
	Copper	-	<20ppm	NR	NR
	Cupronickel	-	<150 ppm	NR	NR
	304 SS	-	<400 ppm	<250 ppm	<150 ppm
316 SS	-	<1000 ppm	<550 ppm	< 375 ppm	
Titanium	-	>1000 ppm	>550 ppm	>375 ppm	
Erosion and Clogging					
Particulate Size and Erosion	All	<10 ppm of particles and a maximum velocity of 1.8 m/s Filtered for maximum 841 micron [0.84 mm, 20 mesh] size.	<10 ppm (<1 ppm "sandfree" for reinjection) of particles and a maximum velocity of 1.8 m/s. Filtered for maximum 841 micron 0.84 mm, 20 mesh] size. Any particulate that is not removed can potentially clog components.		

The Water Quality Table provides water quality requirements for coaxial heat exchangers. The water should be evaluated by an independent testing facility comparing to this Table and when properties are outside of these requirements, an external secondary heat exchanger must be used to isolate the heat pump heat exchanger from the unsuitable water. Failure to do so will void the warranty for the coaxial heat exchanger and any other components damaged by a leak.

Notes:

- Closed Recirculating system is identified by a closed pressurized piping system.
- Recirculating open wells should observe the open recirculating design considerations.
- NR - Application not recommended.
- "-" No design Maximum.

HB - Horizontal – Dimensional Data

Horizontal Model		Overall Cabinet		
		A Width	B Length	C Height
006 - 012	in cm	19.1 48.5	34.1 86.6	11.1 28.2
015 - 018	in cm	20.1 51.1	43.1 109.5	17.0 43.2
024 - 030	in cm	20.1 51.1	43.1 109.5	18.3 46.5
036 - 042	in cm	20.1 51.1	47.1 119.6	21.0 53.3
048 - 060	in cm	24.1 61.2	54.1 137.4	21.0 53.3

Horizontal Model		Electrical Knockouts	
		J 1/2"	K 3/4"
		Low Voltage	Power Supply
006 - 012	in cm	5.1 13.0	2.1 5.4
015 - 018	in cm	9.9 25.2	6.9 17.5
024 - 030	in cm	11.1 28.2	8.1 20.6
036 - 060	in cm	13.9 35.3	10.9 27.7

Horizontal Model		Water Connections						Loop In/Out FPT
		①		②		③		
		Loop In D	Loop In E	Loop Out F	Loop Out G	AA	BB	
006 - 012	in cm	5.6 14.2	1.1 2.7	1.6 4.1	1.1 2.7	3.3 8.4	0.7 1.8	1/2"
015	in cm	15.1 38.4	1.4 3.4	3.2 8.1	1.4 3.5	3.3 8.4	0.7 1.8	1/2"
018	in cm	15.1 38.4	1.4 3.4	4.1 10.4	1.4 3.5	3.3 8.4	0.7 1.8	1/2"
024	in cm	16.4 41.7	1.4 3.4	4.4 11.3	1.4 3.5	3.3 8.4	0.7 1.8	3/4"
030	in cm	16.4 41.7	1.4 3.4	3.1 7.8	1.4 3.5	3.3 8.4	0.7 1.8	3/4"
036	in cm	19.1 48.5	1.4 3.4	5.3 13.4	1.4 3.5	3.3 8.4	0.7 1.8	3/4"
042	in cm	19.1 48.5	1.4 3.4	4.4 11.3	1.4 3.5	3.3 8.4	0.7 1.8	3/4"
048	in cm	19.1 48.5	1.4 3.4	4.4 11.1	1.4 3.5	3.3 8.4	0.7 1.8	1"
060	in cm	19.1 48.5	1.4 3.4	3.8 9.7	1.4 3.5	3.3 8.4	0.7 1.8	1"

Horizontal Model		Discharge Connection Duct Flange Installed (+/- 0.10 in, +/- 2.5mm)					Return Connection Using Return Air Opening			
		L	M Supply Height	N Supply Width	O	P	Q Return Width	R Return Height	S	T
006 - 012	in cm	0.8 1.9	8.9 22.7	6.7 17.0	6.0 15.2	1.3 3.3	16.1 41.0	9.8 25.0	1.1 2.7	0.6 1.5
015 - 018	in cm	2.6 6.6	13.3 33.8	9.9 25.1	4.1 10.5	1.3 3.3	23.0 58.4	15.0 38.1	1.1 2.8	1.0 2.5
024 - 030	in cm	2.6 6.6	13.3 33.8	9.9 25.1	4.1 10.5	1.3 3.3	23.0 58.4	16.3 41.4	1.1 2.8	1.0 2.5
036 - 042	in cm	2.5 6.3	16.1 40.9	11.0 27.9	3.0 7.7	2.5 6.4	25.9 65.8	19.0 48.3	1.1 2.8	1.0 2.5
048	in cm	3.7 9.5	16.1 41.0	13.7 34.8	4.1 10.3	1.3 3.2	35.9 91.2	19.0 48.3	1.1 2.8	1.0 2.5
060	in cm	1.7 4.4	18.1 46.0	13.7 34.8	4.1 10.3	1.3 3.2	35.9 91.2	19.0 48.3	1.1 2.8	1.0 2.5

HB - Horizontal – Dimensional Data, Cont'd.

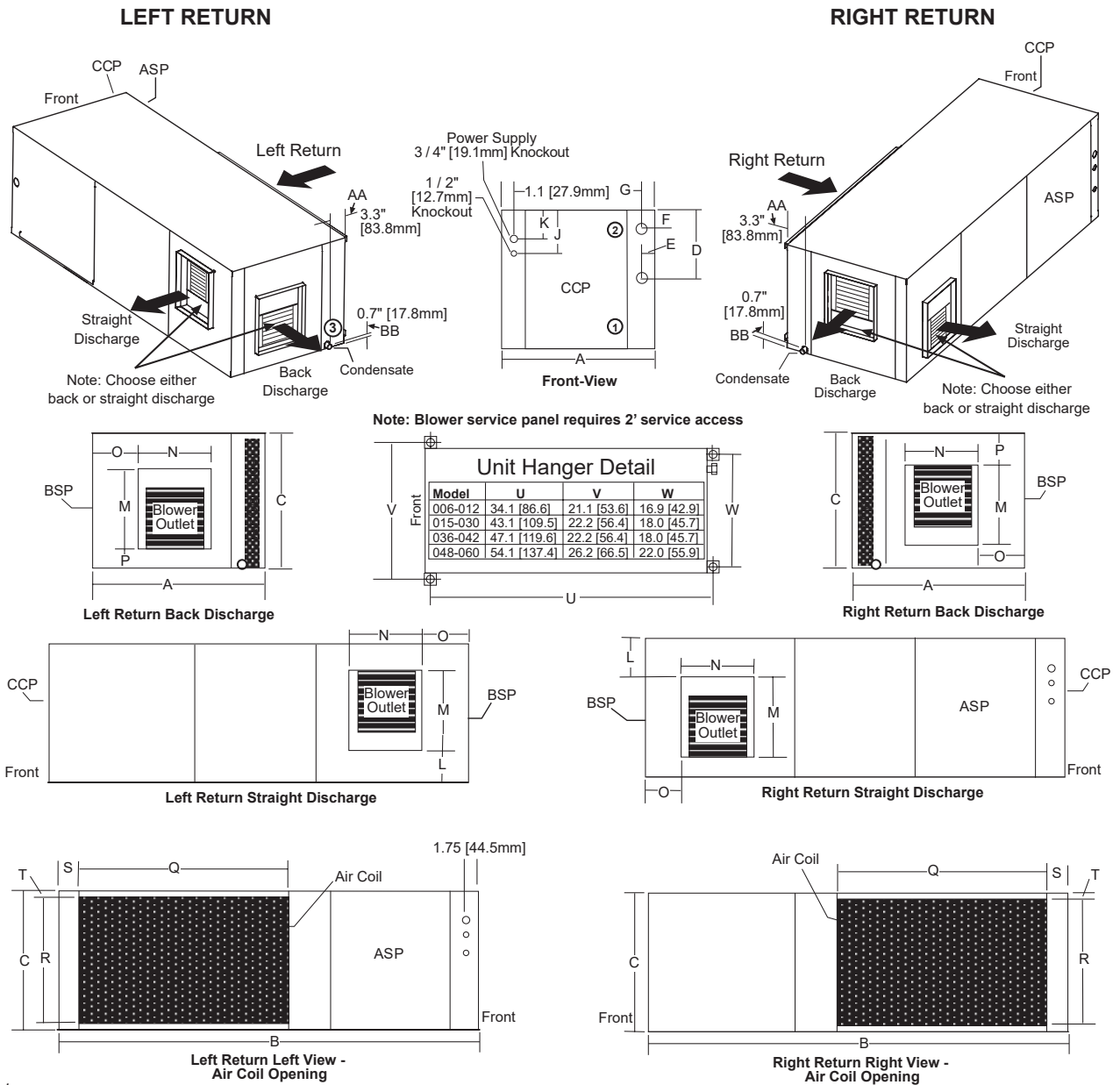

Notes:

1. While clear access to all removable panels is not required, installer should take care to comply with all building codes and allow adequate clearance for future field service.
2. Units are shipped with air filter rails that are not suitable for supporting return air ductwork. An air filter frame with duct mounting collar is available as an accessory, see the Accessory Submittal set for further information on this frame.
3. Discharge flange and hanger brackets are factory installed.
4. Condensate fitting on Polymer drain pan is rubber coupling that couples to 3/4" schedule 40/80 PVC, S.S. drain pan is 3/4" MPT.
5. Blower service panel requires 2' service access.
6. Blower service access is through back panel on straight discharge units or through panel opposite air coil on back discharge units

Legend:

CCP = Control/Compressor Access Panel
 BSP = Blower Service Panel
 *ASP = Additional Service Panel (not required)

Note:

*ASP are removable panels that provide additional access to the units interior. Clear access to ASP panels is not required and they are not to be used in place of the mandatory CCP and BSP panels.

HBH with Left Hand Waterside Economizer – Dimensional Data

Horizontal Model		Overall Cabinet				WSE	Left WSE Connections						Return Connection Using Return Air Opening				
		A Width	B Length	C Height	H Width		In		Out		Cond. 3/4" MPT		Water In/Out FPT	Q Return Width	R Return Height	S	T
							D	E	F	G	AA	BB					
006-012	in	26.1	34.1	11.0	7.1	4.7	3.5	8.0	3.5	3.5	0.8	1/2"	16.1	10.0	1.5	0.3	
	cm	66.3	86.6	27.9	18.0	11.9	8.9	20.3	8.9	8.9	2.0		40.9	25.4	3.8	0.8	
015-018	in	27.2	43.1	17.0	7.1	5.3	3.5	11.5	3.5	3.5	0.8	1/2"	23.0	16.0	1.5	0.3	
	cm	69.1	109.5	43.2	18.0	13.5	8.9	29.2	8.9	8.9	2.0		58.4	40.6	3.8	0.8	
024-030	in	27.2	43.1	18.2	7.1	5.1	3.5	21.1	3.5	3.5	0.8	3/4"	22.9	16.0	1.5	0.3	
	cm	69.1	109.5	46.2	18.0	13.0	8.9	53.6	8.9	8.9	2.0		58.2	40.6	3.8	0.8	
036-042	in	27.2	47.1	21.0	7.1	6.5	3.5	14.0	3.5	3.5	0.8	3/4"	26.0	20.0	1.5	0.3	
	cm	69.1	119.6	53.3	18.0	16.5	8.9	35.6	8.9	8.9	2.0		66.0	50.8	3.8	0.8	
048-060	in	31.6	54.1	21.0	7.5	5.0	1.3	15.9	1.3	3.5	0.8	3/4"	36.0	20.0	1.5	0.3	
	cm	80.3	137.4	53.3	19.1	12.7	3.3	40.4	3.3	8.9	2.0		91.4	50.8	3.8	0.8	

Left Return HBH with WSE

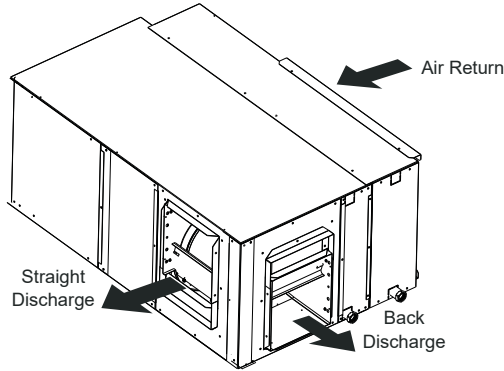

Unit Hanger Detail			
Model	U	V	W
006-012	34.1 [86.6]	21.1 [53.6]	16.9 [42.9]
015-030	43.1 [109.5]	22.2 [56.4]	18.0 [45.7]
036-042	47.1 [119.6]	22.2 [56.4]	18.0 [45.7]
048-060	54.1 [137.4]	26.2 [66.5]	22.0 [55.9]

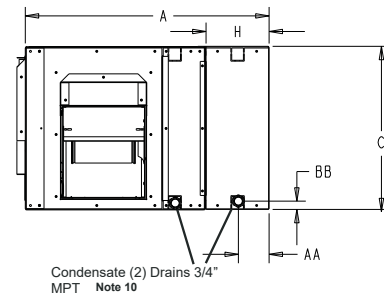
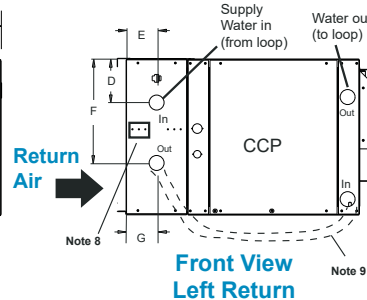
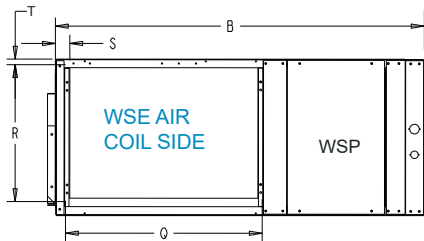

Back View

Notes:

- While clear access to all removable panels is not required, installer should take care to comply with all building codes and allow adequate clearance for future field service.
- Units are shipped with air filter rails that are not suitable for supporting return air ductwork. An air filter frame with duct mounting collar is available as an accessory, see the Accessory Submittal set for further information on this frame.
- Discharge flange and hanger brackets are factory installed.
- Condensate drains are 3/4" MPT.
- Blower service panel requires 2' service access.
- Blower service access is through back panel on straight discharge units or through panel opposite air coil on back discharge units.
- Filters same size as standard unit
- Factory supplied controller (aquastat) is shipped inside unit. Open waterside economizer panel (WSP), remove, slide onto drainrail, and connect molex.
- WSE to unit piping to be field fabricated, Run below or in front. Must leave room to remove front access panel (CCP) to service unit.
- External trap and vent both drains before joining.
- For Discharge air connection dimensions see page 20 and 21.

HBH with Right Hand Waterside Economizer – Dimensional Data

Horizontal Model		Overall Cabinet			WSE	Left WSE Connections						Return Connection Using Return Air Opening				
		A Width	B Length	C Height	H Width	In		Out		Cond. 3/4" MPT		Water In/Out FPT	Q Return Width	R Return Height	S	T
						D	E	F	G	AA	BB					
006-012	in	26.1	34.1	11.0	7.1	8.0	3.5	4.7	3.5	3.5	0.8	1/2"	16.1	10.0	1.5	0.3
	cm	66.3	86.6	27.9	18.0	20.3	8.9	11.9	8.9	8.9	2.0		40.9	25.4	3.8	0.8
015-018	in	27.2	43.1	17.0	7.1	11.5	3.5	5.3	3.5	3.5	0.8	1/2"	23.0	16.0	1.5	0.3
	cm	69.1	109.5	43.2	18.0	29.2	8.9	13.5	8.9	8.9	2.0		58.4	40.6	3.8	0.8
024-030	in	27.2	43.1	18.2	7.1	21.1	3.5	5.1	3.5	3.5	0.8	3/4"	22.9	16.0	1.5	0.3
	cm	69.1	109.5	46.2	18.0	53.6	8.9	13.0	8.9	8.9	2.0		58.2	40.6	3.8	0.8
036-042	in	27.2	47.1	21.0	7.1	14.0	3.5	6.5	3.5	3.5	0.8	3/4"	26.0	20.0	1.5	0.3
	cm	69.1	119.6	53.3	18.0	35.6	8.9	16.5	8.9	8.9	2.0		66.0	50.8	3.8	0.8
048-060	in	31.6	54.1	21.0	7.5	15.9	1.3	5.0	1.3	3.5	0.8	3/4"	36.0	20.0	1.5	0.3
	cm	80.3	137.4	53.3	19.1	40.4	3.3	12.7	3.3	8.9	2.0		91.4	50.8	3.8	0.8

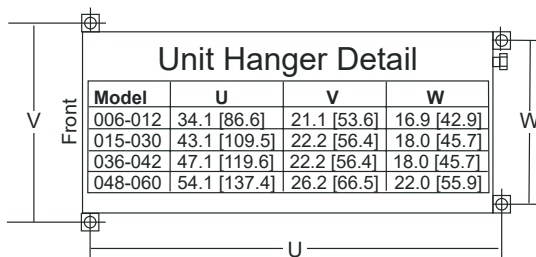

Right Return HBH with WSE

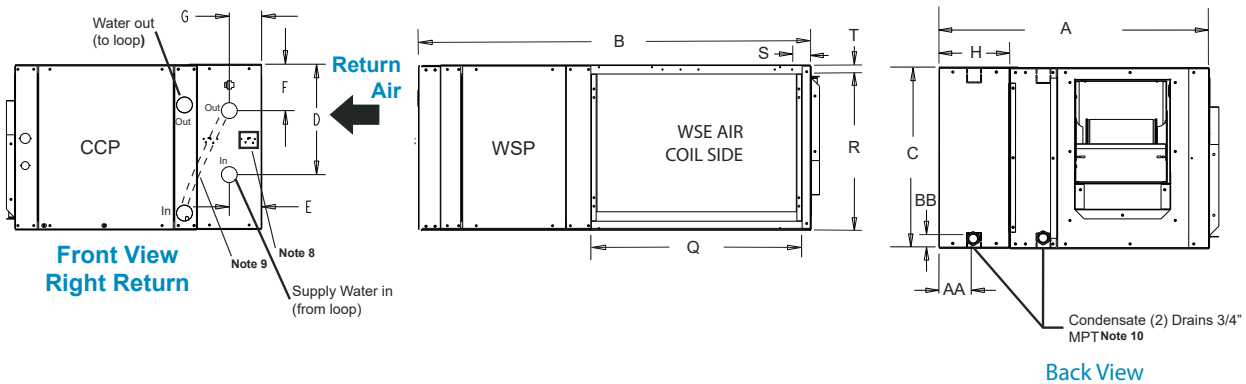
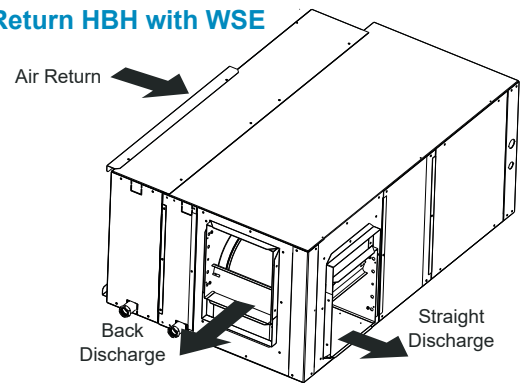

Notes:

1. While clear access to all removable panels is not required, installer should take care to comply with all building codes and allow adequate clearance for future field service.
2. Units are shipped with air filter rails that are not suitable for supporting return air ductwork. An air filter frame with duct mounting collar is available as an accessory, see the Accessory Submittal set for further information on this frame.
3. Discharge flange and hanger brackets are factory installed.
4. Condensate drains are 3/4" MPT.
5. Blower service panel requires 2' service access.
6. Blower service access is through back panel on straight discharge units or through panel opposite air coil on back discharge units.
7. Filters same size as standard unit
8. Factory supplied controller (aquastat) is shipped inside unit open waterside economizer panel (WSP), remove, slide onto drainrail, and connect molex.
9. WSE to unit piping to be field fabricated. Run below or in front. Must leave room to remove front access panel (CCP) to service unit.
10. External trap and vent both drains before joining.
11. For Discharge air connection dimensions see page 20 and 21.

HB - Horizontal Service Access

Left Return Back Discharge

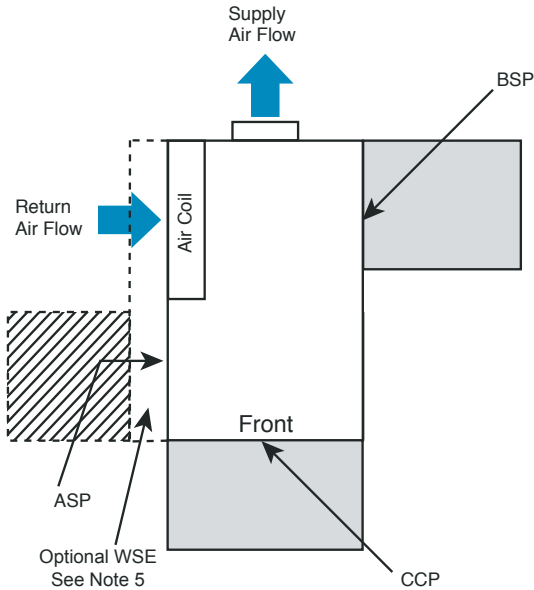

Right Return Back Discharge

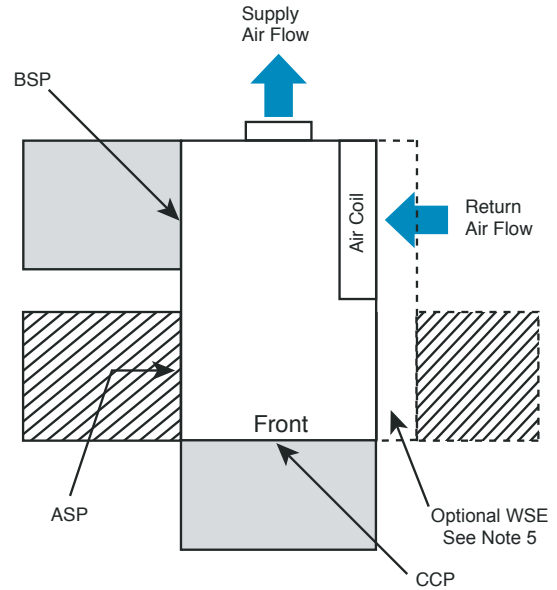

Left Return Straight Discharge

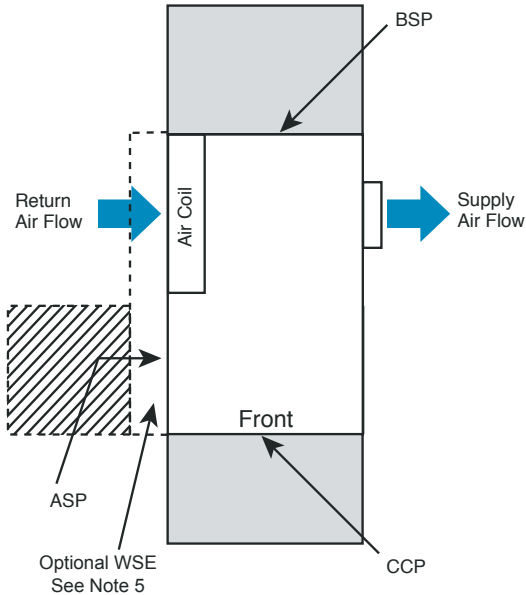

Right Return Straight Discharge

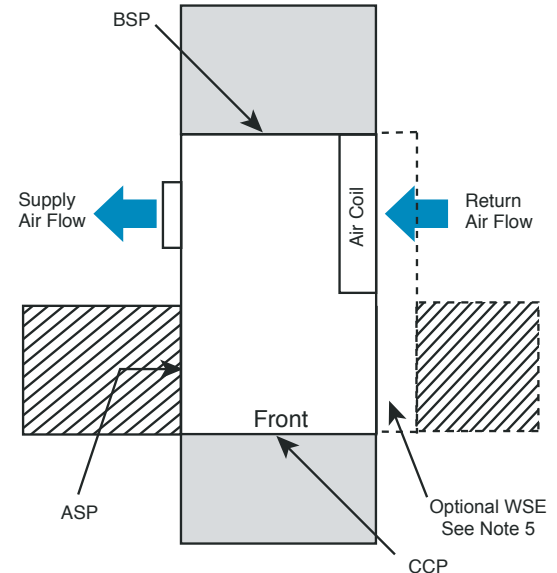

Notes:

1. While clear access to all removable panels is not required, installer should take care to comply with all building codes and allow adequate clearance for future field service.
2. CCP and BSP requires 2' service access.
3. Blower service access is through back panel on straight discharge units or through panel opposite air coil on back discharge units.
4. ASP are removable panels that provide additional access to the units interior. Clear access to ASP panels is not required and they are not to be used in place of the mandatory CCP and BSP panels.
5. Units with WSE must have access to water valve through side access panel.

= mandatory 2' service access

= (optional) additional 2' service access

Legend:

CCP = Control/Compressor Access Panel

BSP = Blower Service Panel

ASP = Additional Service Panel (not required)

WSE = Waterside Economizer

HB - Vertical Upflow – Dimensional Data

Vertical Upflow Model		Overall Cabinet		
		A Width	B Depth	C Height
006 - 012	in	19.1	19.1	22.0
	cm	48.5	48.5	55.9
015 - 030, 041	in	21.5	21.5	40.0
	cm	54.6	54.6	101.6
036 - 042	in	21.5	26.0	45.0
	cm	54.6	66.0	114.3
048 - 060	in	24.0	32.5	46.0
	cm	61.0	82.6	116.8

Vertical Model		Electrical Knockouts	
		J 1/2"	K 3/4"
		Low Voltage	Power Supply
006 - 012	in	5.9	8.9
	cm	14.9	22.5
015 - 060	in	7.1	10.1
	cm	18.1	25.7
041	in	7.1	11.1
	cm	18.0	28.2

Vertical Upflow Model		Water Connections - Standard Units						
		1		2		3		Loop In/Out FPT
		Loop In D	Loop In E	Loop Out F	Loop Out G	H	I	
006 - 012	in	1.5	1.5	9.5	1.5	11.7	1.4	1/2"
	cm	3.8	3.8	24.1	3.8	30.5	3.6	
015	in	1.9	1.4	13.8	1.4	19.7	1.4	1/2"
	cm	4.8	3.6	35.1	3.6	50.8	3.6	
018	in	1.9	1.4	13.8	1.4	19.7	1.4	1/2"
	cm	4.8	3.6	35.1	3.6	50.8	3.6	
024	in	1.9	1.4	13.8	1.4	19.7	1.4	3/4"
	cm	4.8	3.6	35.1	3.6	50.8	3.6	
030	in	1.9	1.4	15.2	1.4	19.7	1.4	3/4"
	cm	4.8	3.6	38.6	3.6	50.8	3.6	
036	in	1.9	1.4	15.2	1.4	20.6	1.4	3/4"
	cm	4.8	3.6	38.6	3.6	52.3	3.6	
041	in	3.6	2.3	14.0	2.3	18.3	2.3	3/4"
	cm	4.8	5.8	35.6	5.8	46.5	5.8	
042	in	1.9	1.4	16.6	1.4	20.6	1.4	3/4"
	cm	4.8	3.6	42.0	3.6	53.3	3.6	
048	in	2.0	1.4	16.9	1.4	21.6	1.4	1"
	cm	5.1	3.6	42.9	3.6	55.9	3.6	
060	in	2.0	1.4	17.4	1.4	21.6	1.4	1"
	cm	5.1	3.6	44.2	3.6	55.9	3.6	

Notes:

- While clear access to all removable panels is not required, installer should take care to comply with all building codes and allow adequate clearance for future field service.
- Front & Side access is preferred for service access. However, all components may be serviced from the front access panel if side access is not available. (Except on HBV 009-030 with front return) Units with the front return require left side access for the fan.
- Discharge flange is field installed.
- Condensate fitting on Polymer drain pan is rubber coupling that couples to 3/4" schedule 40/80 PVC, S.S. drain pan is 3/4" MPT.
- Units are shipped with air filter rails that are not suitable for supporting return air ductwork. An air filter frame with duct mounting collar is available as an accessory, see the Comfort Aire/Century Accessory Submittal set for further information on this frame.

Legend:

- CCP = Control/Compressor Access Panel
- BSP = Blower Service Panel
- ASP = Alternative Service Panel

Recommended Minimum Installation Clearances for Vertical Units*	
1"	Back of unit
	Side opposite return air
6"	Front if hard piped
Return Air Side	
1"	Ducted return
	- ‡ *Add for duct width
	- † Add 2" for 1" filter frame/rail or 3" for 2" filter frame/rail
Free (open) return - calculate required dimension for a maximum velocity of 600 fpm	

*Field installed accessories (hoses, air cleaners, etc.) and factory WSE option will require additional space. Top supply air is shown, the same clearances apply to bottom supply air units.

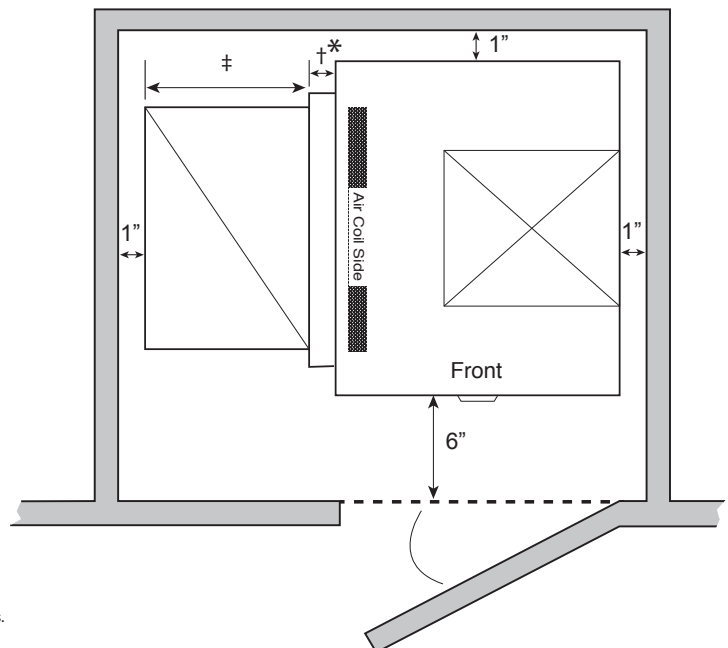

HBV - Vertical Upflow – Dimensional Data, Cont'd.

Vertical Model		Discharge Connection Duct Flange Installed (+/- 0.10 in, +/- 2.5mm)					Return Connection Using Return Air Opening			
		M	N	O Supply Width	P Supply Depth	Q	R	S Return Depth	T Return Height	U
006 - 012	in	8.9	5.1	9.0	9.0	5.5	2.1	16.2	9.9	0.7
	cm	22.7	12.9	22.9	22.9	14.0	5.3	41.1	25.1	1.9
015 - 018	in	6.4	3.8	14.0	14.0	5.3	2.3	18.3	20.9	0.7
	cm	16.1	9.5	35.6	35.6	13.6	5.8	46.5	53.1	1.9
024 - 030, *041	in	6.4	5.0	14.0	14.0	5.8	2.0	18.5	19.3	0.9
	cm	16.3	12.7	35.6	35.6	14.7	5.1	47.0	49.0	2.3
036 - 042	in	6.4	3.8	14.0	14.0	5.1	2.3	22.8	23.9	0.7
	cm	16.1	9.5	35.6	35.6	13.1	5.8	57.9	60.7	1.9
048 - 060	in	6.9	7.3	16.0	18.0	5.1	2.3	29.3	22.5	0.7
	cm	17.4	18.4	40.6	45.7	13.1	5.8	74.4	57.0	1.9

Front Return - N = 4.8 in (12.2 cm), Q = 6.4 in (16.3 cm).

Right Return - N = 3.8 in (9.7 cm), Q = 5.5 in (14.0 cm).

Left Return - M = 6.4 in (16.3 cm), N = 2.8 in (7.1 cm).

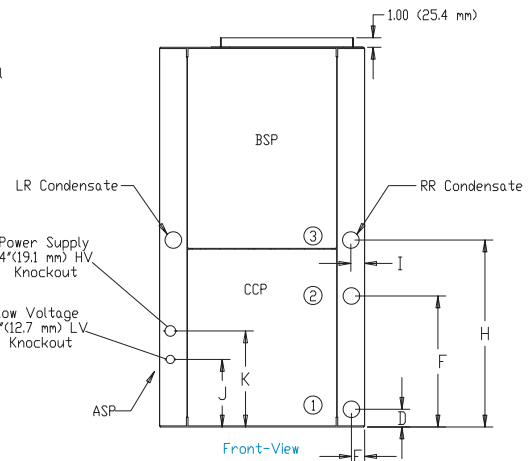
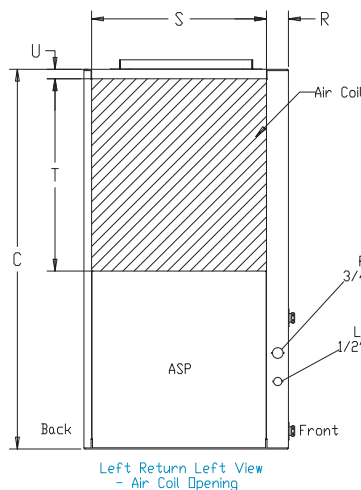
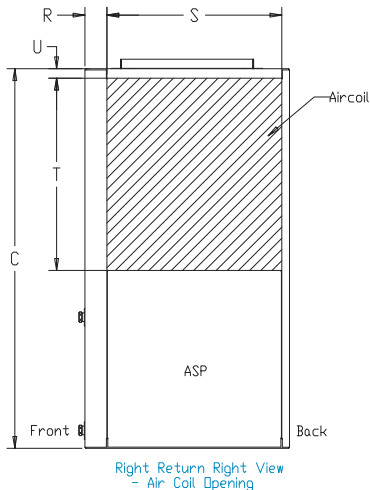
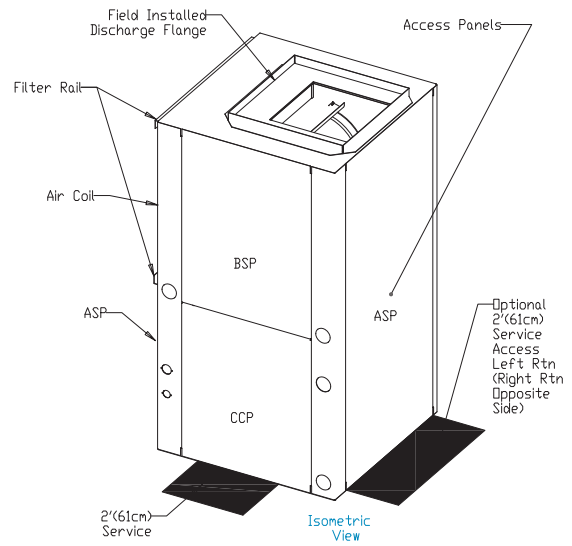
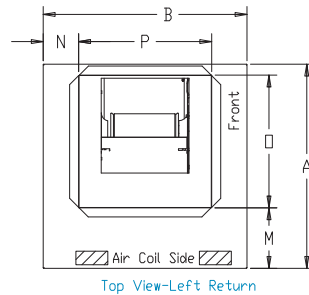
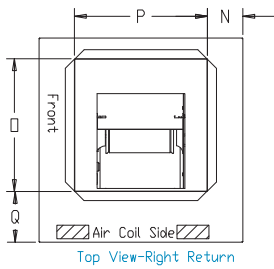
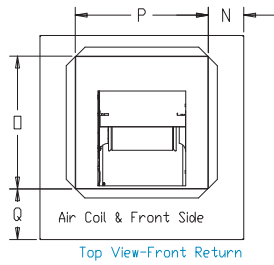

Units are shipped with air filter rails that are not suitable for supporting return air ductwork. An air filter frame with duct mounting collar is available as an accessory, see the Accessory Submittal set for further information on this frame.

HBV with Left Hand Waterside Economizer – Dimensional Data

Vertical Model		Overall Cabinet				WSE	WSE Connections						Return Connection Using Return Air Opening				
		A Width	B Length	C Height	H Width		In		Out		Cond. 3/4" MPT		Water In/Out FPT	Q Return Width	R Return Height	S	T
							D	E	F	G	AA	BB					
006-012	in	26.1	21.2	22.0	7.1	8.1	5.5	2.1	5.5	5.1	5.5	1/2"	16.1	10.0	4.2	0.4	
	cm	66.3	53.8	55.9	18.0	20.6	14.0	5.3	14.0	13.0	14.0		40.9	25.4	10.7	1.0	
015-030	in	29.0	24.7	40.0	7.4	11.6	6.0	2.6	6.0	7.1	6.0	3/4"	18.1	20.0	3.8	0.3	
	cm	73.7	62.7	101.6	18.8	29.5	15.2	6.6	15.2	18.0	15.2		46.0	50.8	9.7	0.8	
036-042	in	29.0	28.7	45.0	7.4	12.1	6.0	2.6	6.0	7.1	6.0	3/4"	22.7	24.0	4.6	0.1	
	cm	73.7	72.9	114.3	18.8	29.5	15.2	6.6	15.2	18.0	15.2		57.7	61.0	11.7	0.3	
048-060	in	31.2	37.2	46.0	7.0	12.1	5.8	3.1	5.8	7.1	5.8	3/4"	29.3	24.0	5.0	0.1	
	cm	79.2	94.5	116.8	17.8	30.7	14.7	7.9	14.7	18.0	14.7		74.4	61.0	12.7	0.3	

Left Return HBV with WSE

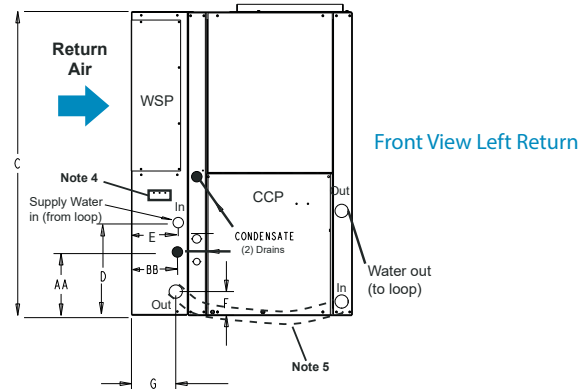
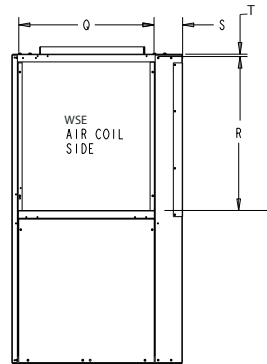
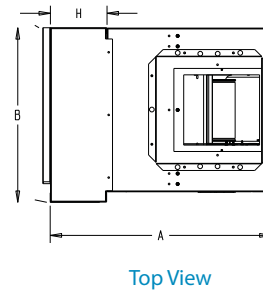
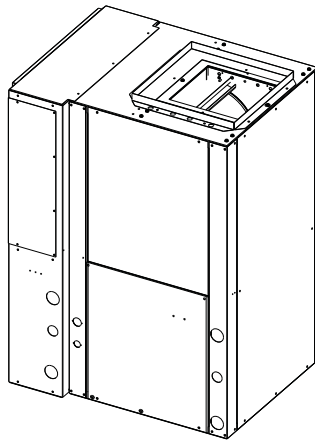

Notes:

- Units are shipped with air filter rails that are not suitable for supporting return air ductwork. An air filter frame with duct mounting collar is available as an accessory, see the Accessory Submittal set for further information on this frame.
- WSE condensate drain is 3/4" FPT, Unit condensate drain is 3/4" MPT. Externally trap and vent both drains before joining.
- Filters same size as standard unit.
- Factory supplied controller (aquastat) is shipped inside unit. Open waterside economizer panel (WSP), remove, slide onto dinrail, and connect molex.
- WSE to unit piping to be field fabricated, run below or in front. Must leave room to remove front access panel (CCP) to service unit.
- For Discharge air connection dimensions see page 26.

HBV with Right Hand Waterside Economizer – Dimensional Data

Vertical Model		Overall Cabinet			WSE	WSE Connections						Return Connection Using Return Air Opening				
		A	B	C	H	In		Out		Cond. 3/4" MPT		Water In/Out FPT	Q	R	S	T
		Width	Length	Height	Width	D	E	F	G	AA	BB		Return Width	Return Height		
006-012	in	26.1	21.2	22.0	7.1	2.1	5.5	8.1	5.5	5.1	5.5	1/2"	16.1	10.0	4.2	0.4
	cm	66.3	53.8	55.9	18.0	5.3	14.0	20.6	14.0	13.0	14.0		40.9	25.4	10.7	1.0
015-030	in	29.0	24.7	40.0	7.4	2.6	6.0	11.6	6.0	7.1	6.0	3/4"	18.1	20.0	3.8	0.3
	cm	73.7	62.7	101.6	18.8	6.6	15.2	29.5	15.2	18.0	15.2		46.0	50.8	9.7	0.8
036-042	in	29.0	28.7	45.0	7.4	2.6	6.0	12.1	6.0	7.1	6.0	3/4"	22.7	24.0	4.6	0.1
	cm	73.7	72.9	114.3	18.8	6.6	15.2	29.5	15.2	18.0	15.2		57.7	61.0	11.7	0.3
048-060	in	31.2	37.2	46.0	7.0	3.1	5.8	12.1	5.8	7.1	5.8	3/4"	29.3	24.0	5.0	0.1
	cm	79.2	94.5	116.8	17.8	7.9	14.7	30.7	14.7	18.0	14.7		74.4	61.0	12.7	0.3

Right Return HBV with WSE

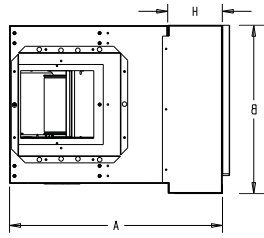

Top View

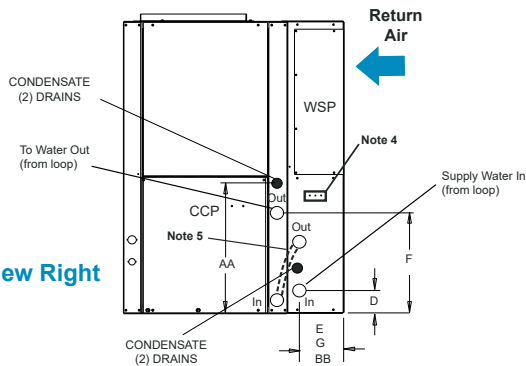
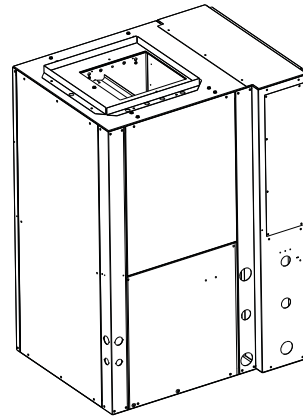

Front View Right Return

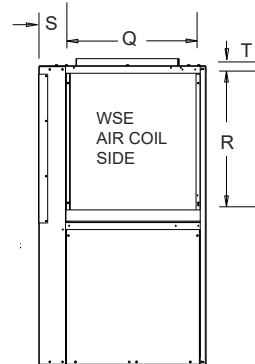

Notes:

- Units are shipped with air filter rails that are not suitable for supporting return air ductwork. An air filter frame with duct mounting collar is available as an accessory, see the Accessory Submittal set for further information on this frame.
- WSE condensate drain is 3/4" FPT, Unit condensate drain is 3/4" MPT. Externally trap and vent both drains before joining.
- Filters same size as standard unit.
- Factory supplied controller (aquastat) is shipped inside unit. Open waterside economizer panel (WSP), remove, slide onto dinrail, and connect molex.
- WSE to unit piping to be field fabricated below or in front. Must leave room to remove front access panel (CCP) to service unit.
- For Discharge air connection dimensions see page 26.

HB - Vertical Service Access

Vertical Units

Left Return

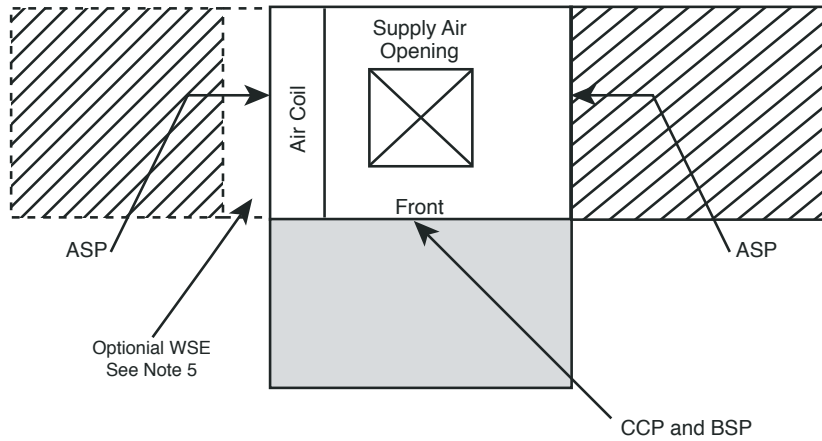

Right Return

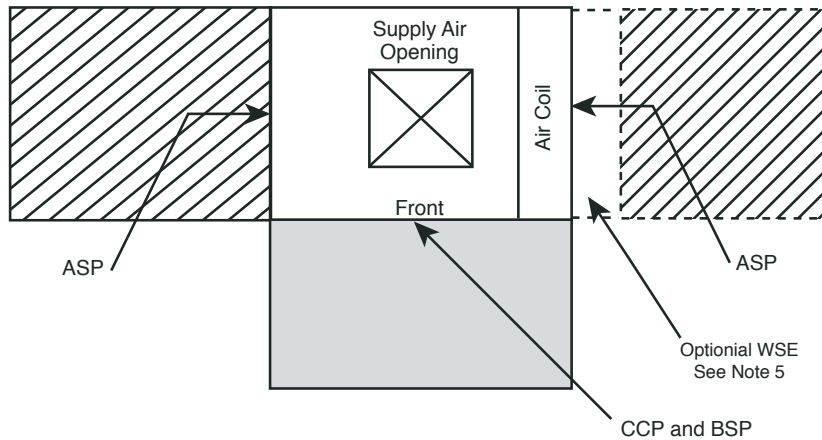

Notes:

1. While clear access to all removable panels is not required, installer should take care to comply with all building codes and allow adequate clearance for future field service.
2. Front & Side access is preferred for service access. However, units without WSE option may be serviced from the front access panel if side access is not available.
3. ASP are removable panels that provide additional access to the units interior. Clear access to ASP panels is not required and they are not to be used in place of the mandatory CCP and BSP panels.
4. Front return units (not shown) require front access for controls/compressor and left side access for blower.
5. Units with WSE Must have access to water valve through side access panel.

- = mandatory 2' service access
- = (optional) additional 2' service access

Legend:
 CCP = Control/Compressor Access Panel
 BSP = Blower Service Panel
 ASP = Additional Service Panel (not required)
 WSE = Waterside Economizer

Electrical Data – PSC

Table 4: Electrical Data - PSC

Size	VOLTAGE CODE	RATED VOLTAGE	VOLTAGE MIN/MAX	COMPRESSOR			STANDARD PSC				HI STATIC PSC							
				QTY	RLA	LRA	FAN MOTOR FLA	TOTAL UNIT FLA	MIN CIRCUIT AMP	MAX FUSE/HACR	FAN MOTOR FLA	TOTAL UNIT FLA	MIN CIRCUIT AMP	MAX FUSE/HACR				
6	1	208-230 / 60 / 1	187.2 / 253	1	2.6	17.7	0.3	2.9	3.6	15A								
	8	265 / 60 / 1	238.5 / 291.5	1	2.6	13.5	0.4	3.0	3.6	15A								
9	1	208-230 / 60 / 1	187.2 / 253	1	3.7	22	0.8	4.5	5.5	15A								
	8	265 / 60 / 1	238.5 / 291.5	1	3.4	17.5	0.8	4.2	5.1	15A								
12	1	208-230 / 60 / 1	187.2 / 253	1	5.6	32.5	0.8	6.4	7.8	15A								
	8	265 / 60 / 1	238.5 / 291.5	1	4.2	31.5	0.8	5.0	6.1	15A								
15	1	208-230 / 60 / 1	187.2 / 253	1	5.6	29	0.9	6.5	7.9	15A					0.9	6.5	7.9	15A
	8	265 / 60 / 1	238.5 / 291.5	1	5	28	0.7	5.7	7.0	15A					0.7	5.7	7.0	15A
18	1	208-230 / 60 / 1	187.2 / 253	1	7.4	33	0.9	8.3	10.2	15A					0.9	8.3	10.2	15A
	8	265 / 60 / 1	238.5 / 291.5	1	6	28	0.7	6.7	8.2	15A					0.7	6.7	8.2	15A
24	1	208-230 / 60 / 1	187.2 / 253	1	12.8	58.3	1.5	14.3	17.5	30A					2.7	15.5	18.7	30A
	8	265 / 60 / 1	238.5 / 291.5	1	9.6	54	1.2	10.8	13.2	20A					2.9	12.5	14.9	20A
	4	460 / 60 / 3	414 / 506	1	3.6	28	1.4	5.0	5.9	15A	1.6	5.2	6.1	15A				
	3	208-230 / 60 / 3	187.2 / 253	1	7.7	55.4	1.5	9.2	11.1	15A	2.7	10.4	12.3	20A				
30	1	208-230 / 60 / 1	187.2 / 253	1	14.1	73	2.7	16.8	20.3	30A	2.7	16.8	20.3	30A				
	8	265 / 60 / 1	238.5 / 291.5	1	11.2	60	2.9	14.1	16.9	25A	2.9	14.1	16.9	25A				
	4	460 / 60 / 3	414 / 506	1	4.2	28	1.6	5.8	6.9	15A	1.6	5.8	6.9	15A				
	3	208-230 / 60 / 3	187.2 / 253	1	8.9	58	2.7	11.6	13.8	20A	2.7	11.6	13.8	20A				
36	1	208-230 / 60 / 1	187.2 / 253	1	16.7	79	2.7	19.4	23.6	40A	2.7	19.4	23.6	40A				
	8	265 / 60 / 1	238.5 / 291.5	1	13.5	72	2.0	15.5	18.9	30A	2.9	16.4	19.8	30A				
	4	460 / 60 / 3	414 / 506	1	5.8	38	1.2	7.0	8.5	15A	1.6	7.4	8.9	15A				
	3	208-230 / 60 / 3	187.2 / 253	1	10.4	73	2.7	13.1	15.7	25A	2.7	13.1	15.7	25A				
42	1	208-230 / 60 / 1	187.2 / 253	1	17.9	112	2.7	20.6	25.1	40A	2.7	20.6	25.1	40A				
	4	460 / 60 / 3	414 / 506	1	6	44	1.6	7.6	9.1	15A	1.6	7.6	9.1	15A				
	3	208-230 / 60 / 3	187.2 / 253	1	13.5	88	2.7	16.2	19.6	30A	2.7	16.2	19.6	30A				
	5	575 / 60 / 3	517.5 / 632.5	1	4.9	34	1.4	6.3	7.5	15A	1.4	6.3	7.5	15A				
48	1	208-230 / 60 / 1	187.2 / 253	1	21.8	117	3.3	25.1	30.6	50A	4.8	26.6	32.1	50A				
	4	460 / 60 / 3	414 / 506	1	6.2	41	1.7	7.9	9.5	15A	2.4	8.6	10.2	15A				
	3	208-230 / 60 / 3	187.2 / 253	1	13.7	83.1	3.3	17.0	20.4	30A	4.8	18.5	21.9	35A				
	5	575 / 60 / 3	517.5 / 632.5	1	4.8	33	1.4	6.2	7.4	15A	1.8	6.6	7.8	15A				
60	1	208-230 / 60 / 1	187.2 / 253	1	26.3	134	4.8	31.1	37.7	60A	5.7	32.0	38.6	60A				
	4	460 / 60 / 3	414 / 506	1	7.8	52	2.4	10.2	12.2	15A	2.5	10.3	12.3	20A				
	3	208-230 / 60 / 3	187.2 / 253	1	15.6	110	4.8	20.4	24.3	40A	5.7	21.3	25.2	40A				
	5	575 / 60 / 3	517.5 / 632.5	1	5.8	38.9	1.8	7.6	9.1	15A	1.9	7.7	9.2	15A				

All fuses Class RK-5

Electrical Data – ECM

Size	VOLTAGE CODE	RATED VOLTAGE	VOLTAGE MIN/MAX	COMPRESSOR			ECM-CV*			
				QTY	RLA	LRA	FAN MOTOR FLA	TOTAL UNIT FLA	MIN CIRCUIT AMP	MAX FUSE/HACR
15	1	208-230 / 60 / 1	187.2 / 253	1	5.6	29	2.6	8.2	9.6	15A
	8	265 / 60 / 1	238.5 / 291.5	1	5	28	2.4	7.4	8.7	15A
18	1	208-230 / 60 / 1	187.2 / 253	1	7.4	33	2.6	10.0	11.9	15A
	8	265 / 60 / 1	238.5 / 291.5	1	6	28	2.4	8.4	9.9	15A
24	1	208-230 / 60 / 1	187.2 / 253	1	12.8	58.3	3.9	16.7	19.9	30A
	8	265 / 60 / 1	238.5 / 291.5	1	9.6	54	3.2	12.8	15.2	20A
	4*	460 / 60 / 3	414 / 506	1	3.6	28	3.2	6.8	7.7	15A
	3	208-230 / 60 / 3	187.2 / 253	1	7.7	55.4	3.9	11.6	13.5	20A
30	1	208-230 / 60 / 1	187.2 / 253	1	14.1	73	3.9	18.0	21.5	35A
	8	265 / 60 / 1	238.5 / 291.5	1	11.2	60	3.2	14.4	17.2	25A
	4*	460 / 60 / 3	414 / 506	1	4.2	28	3.2	7.4	8.5	15A
	3	208-230 / 60 / 3	187.2 / 253	1	8.9	58	3.9	12.8	15.0	20A
36	1	208-230 / 60 / 1	187.2 / 253	1	16.7	79	6.0	22.7	26.9	40A
	8	265 / 60 / 1	238.5 / 291.5	1	13.5	72	4.8	18.3	21.7	35A
	4*	460 / 60 / 3	414 / 506	1	5.8	38	4.8	10.6	12.1	15A
	3	208-230 / 60 / 3	187.2 / 253	1	10.4	73	6.0	16.4	19.0	25A
42	1	208-230 / 60 / 1	187.2 / 253	1	17.9	112	6.0	23.9	28.4	45A
	4*	460 / 60 / 3	414 / 506	1	6	44	4.8	10.8	12.3	15A
	3	208-230 / 60 / 3	187.2 / 253	1	13.5	88	6.0	19.5	22.9	35A
48	1	208-230 / 60 / 1	187.2 / 253	1	21.8	117	7.5	29.3	34.8	50A
	4*	460 / 60 / 3	414 / 506	1	6.2	41	6.2	12.4	14.0	15A
	3	208-230 / 60 / 3	187.2 / 253	1	13.7	83.1	7.5	21.2	24.6	35A
60	1	208-230 / 60 / 1	187.2 / 253	1	26.3	134	7.5	33.8	40.4	60A
	4*	460 / 60 / 3	414 / 506	1	7.8	52	6.0	13.8	15.8	20A
	3	208-230 / 60 / 3	187.2 / 253	1	15.6	110	7.5	23.1	27.0	40A

* 460 volt units with ECM-CV Require a Neutral Wire

All fuses Class RK-5

Electrical – Line Voltage

⚠ WARNING! ⚠

WARNING! Disconnect electrical power source to prevent injury or death from electrical shock.

⚠ CAUTION! ⚠

CAUTION! Use only copper conductors for field installed electrical wiring. Unit terminals are not designed to accept other types of conductors.

Electrical - Line Voltage - All field installed wiring, including electrical ground, must comply with the National Electrical Code as well as all applicable local codes. Refer to the unit electrical data for fuse sizes. Consult wiring diagram for field connections that must be made by the installing (or electrical) contractor. All final electrical connections must be made with a length of flexible conduit to minimize vibration and sound transmission to the building.

General Line Voltage Wiring - Be sure the available power is the same voltage and phase shown on the unit serial plate. Line and low voltage wiring must be done in accordance with local codes or the National Electric Code, whichever is applicable.

Figure 15: Single Phase Line Voltage Field Wiring. Three phase wiring is similar except that all three power wires are directly connected to the contactor.

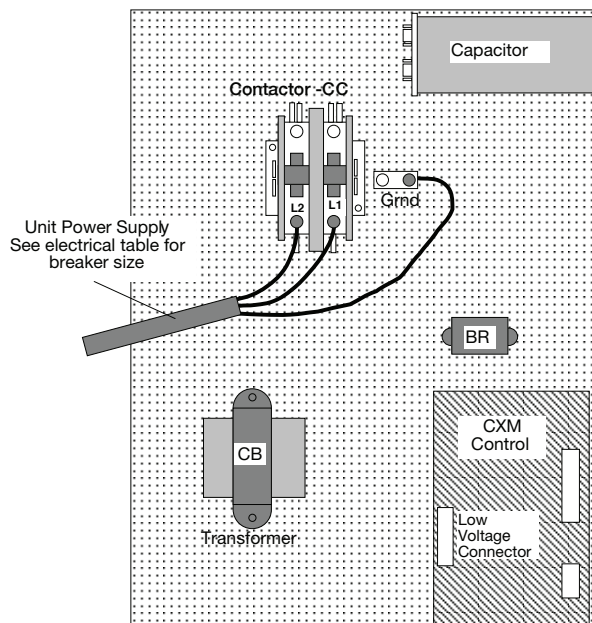

Note: 460V units with Constant Volume ECM motor require a neutral wire.

Power Connection - Line voltage connection is made by connecting the incoming line voltage wires to the “L” side of the contractor as shown in Figure 15. Consult electrical data tables for correct fuse size.

Transformer - All 208/230 voltage units are factory wired for 208 volt. If supply voltage is 230 volt, installer must rewire transformer. See wire diagram for connections.

Blower Speed Selection – Units with PSC Motor - PSC (Permanent Split Capacitor) blower fan speed can be changed by moving the blue wire on the fan motor terminal block to the desired speed as shown in Figure 16. Most units are shipped on the medium speed tap. Consult submittal data or engineering design guide for specific unit airflow tables. Typical unit design delivers rated airflow at nominal static (0.15 in. w.g. [37Pa]) on medium speed and rated airflow at a higher static (0.4 to 0.5 in. w.g. [100 to 125 Pa]) on high speed for applications where higher static is required. Low speed will deliver approximately 85% of rated airflow at 0.10 in. w.g. [25 Pa]. An optional high static blower is available on some models.

Special Note for AHRI Testing: To achieve rated airflow for AHRI testing purposes on all PSC products, it is necessary to change the fan speed to “HI” speed. When the heat pump has experienced less than 100 operational hours and the coil has not had sufficient time to be “seasoned”, it is necessary to clean the coil with a mild surfactant such as Calgon to remove the oils left by manufacturing processes and enable the condensate to properly “sheet” off of the coil.

Figure 16: PSC Motor Speed Selection

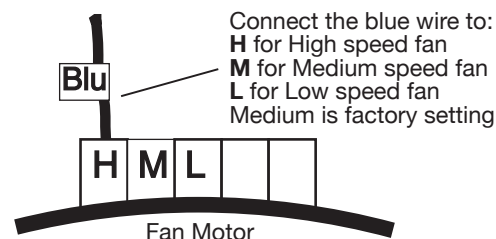

Electrical – Power & Low Voltage Wiring

ELECTRICAL - LOW VOLTAGE WIRING

Thermostat Connections - The thermostat should be wired directly to the CXM or DXM2 board. See “Electrical – Thermostat” for specific terminal connections. Review the appropriate AOM (Application, Operation and Maintenance) manual for units with DDC controls.

Low Water Temperature Cutout Selection - The CXM/DXM2 control allows the field selection of low water (or water-antifreeze solution) temperature limit by clipping jumper JW3, which changes the sensing temperature associated with thermistor LT1. Note that the LT1 thermistor is located on the refrigerant line between the coaxial heat exchanger and expansion device (TXV). Therefore, LT1 is sensing refrigerant temperature, not water temperature, which is a better indication of how water flow rate/temperature is affecting the refrigeration circuit.

The factory setting for LT1 is for systems using water (30°F [-1.1°C] refrigerant temperature). In low water temperature (extended range) applications with antifreeze (most ground loops), jumper JW3 should be clipped as shown in Figure 17 to change the setting to 10°F [-12.2°C] refrigerant temperature, a more suitable temperature when using an antifreeze solution. All units operating with entering water temperatures below 60°F [15.6°C] must include the optional water/refrigerant circuit insulation package to prevent internal condensation.

Figure 17: LT1 Limit Setting

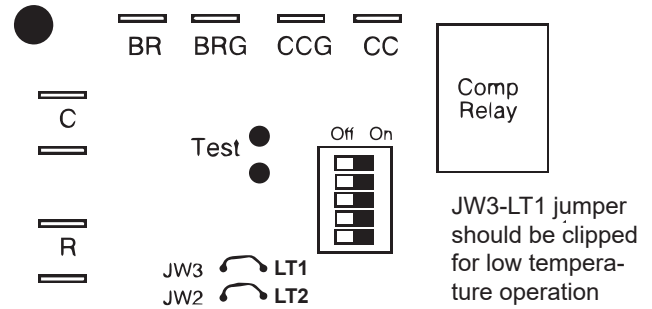

CXM PCB

Models with Waterside Economizer - Assemble controller to DIN rail connect molex connector. Factory settings are 45°F (7.2°C), valve opens, closes at 55°F (12.8°C), and 5 minute short cycle delay. Settings are adjustable.

Electrical – Low Voltage Wiring

Accessory Connections

A terminal paralleling the compressor contactor coil has been provided on the CXM/DXM2 control. Terminal “A” is designed to control accessory devices, such as water valves. Note: This terminal should be used only with 24 Volt signals and not line voltage. Terminal “A” is energized with the compressor contactor. See Figure 18 or the specific unit wiring diagram for details.

Low Voltage VA Ratings

Component	VA
Typical Blower Relay	6 - 7
Typical Reversing Valve Solenoid	4 - 6
30A Compressor Contactor	6 - 9
Subtotal	16 - 22
+ CXM board (5 - 9 VA)*	21 - 31
Remaining VA for Accessories	19 - 29
+ DXM2 board (8 - 12 VA)*	24 - 34
Remaining VA for Accessories	41 - 51

*Standard transformer for CXM board is 50VA.
Optional DXM2 board and/or DDC controls include 75VA transformer.

Figure 18: Accessory Wiring Terminal Strip

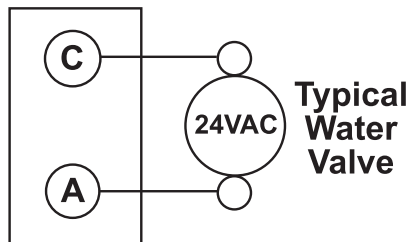

Water Solenoid Valves - An external solenoid valve(s) should be used on ground water installations to shut off flow to the unit when the compressor is not operating. A slow closing valve may be required to help reduce water hammer. Figure 19 shows typical wiring for a 24VAC external solenoid valve. Figures 19 and 20 illustrate the slow closing water control valve wiring for a typical water valve. Slow closing valves take approximately 60 seconds to open (very little water will flow before 45 seconds). Once fully open, an end switch allows the compressor to be energized. Only relay or triac based electronic thermostats should be used with slow closing valves. When wired as shown, the slow closing valve will operate properly with the following notations:

1. The valve will remain open during a unit lockout.
2. The valve will draw approximately 25-35 VA through the “Y” signal of the thermostat.

Note: This valve can overheat the anticipator of an electromechanical thermostat. Therefore, only relay or triac based thermostats should be used.

Figure 19: Valve Wiring

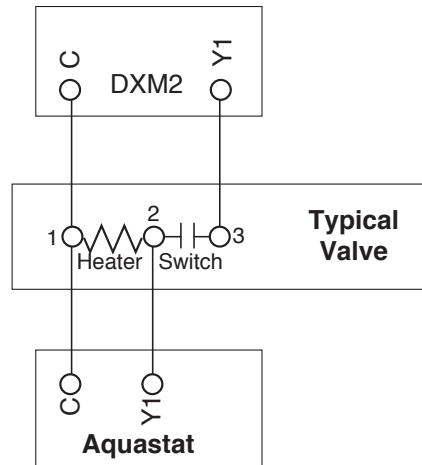
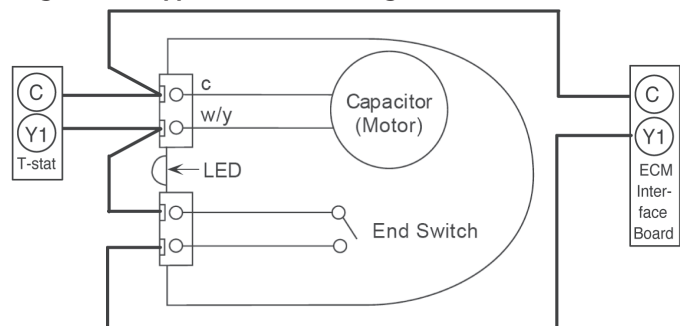

Figure 20: Typical Valve Wiring



Electrical – Thermostat Wiring

Thermostat Installation - The thermostat should be located on an interior wall in a larger room, away from supply duct drafts. DO NOT locate the thermostat in areas subject to sunlight, drafts or on external walls. The wire access hole behind the thermostat may in certain cases need to be sealed to prevent erroneous temperature measurement. Position the thermostat back plate against the wall so that it appears level and so the thermostat wires protrude through the middle of the back plate. Mark

the position of the back plate mounting holes and drill holes with a 3/16" (5mm) bit. Install supplied anchors and secure plate to the wall. Thermostat wire must be 18 AWG wire. Representative thermostat wiring is shown in Figures 21 however, actual wiring connections should be determined from the thermostat IOM and or unit wiring diagram. Practically any heat pump thermostat will work with water source heat pump units, provided it has the correct number of heating and cooling stages.

Figure 21: Units with PSC Fan

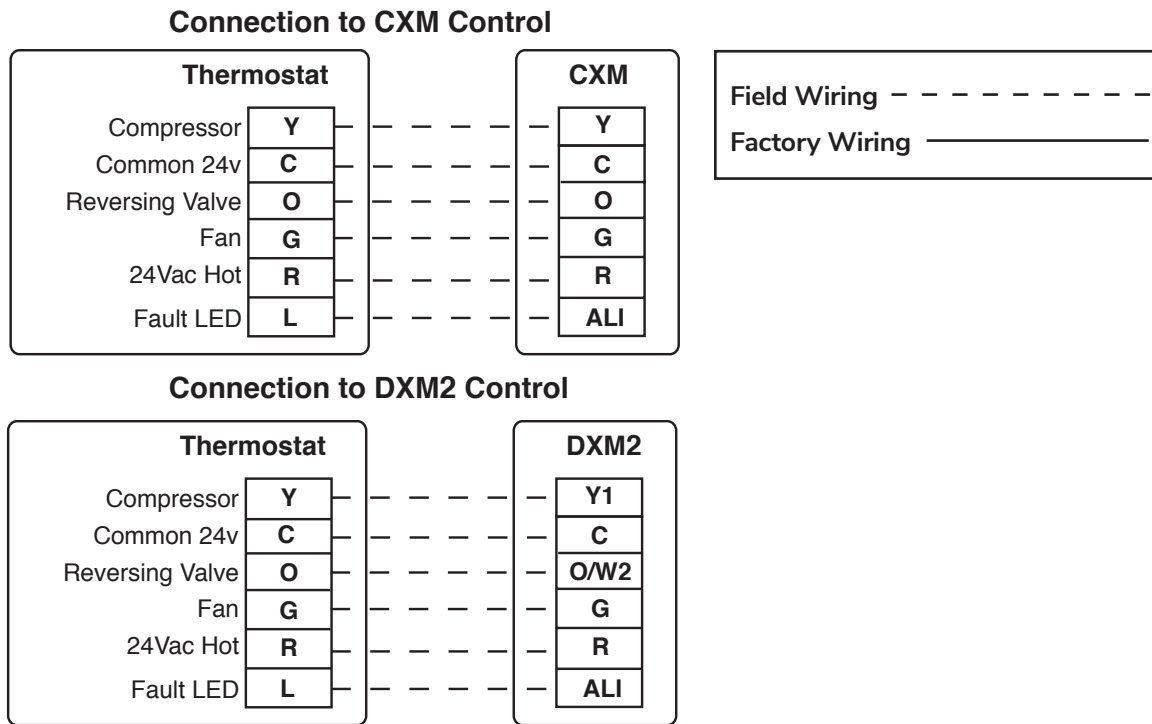

Blower Performance Data – HB006

Blower Type	Speed Mode	Values	External Static Pressure (in. wg)											
			0.1	0.2	0.3	0.4	0.5	0.6	0.7	0.8	0.9	1.0		
PSC - Low Static	Low	CFM	210	190	160									
	Medium	CFM	260	240	210	190								
	High	CFM	310	290	270	230	180							

Airflow is controlled within 5% up to the Max ESP shown with wet coil.
 Do not select Dehumidification mode if HP CFM is on setting 1.
 Black areas denote ESP where operation is not recommended.
 PSC: Units factory shipped on medium speed. Other speeds require field selection.
 All airflow is rated and shown above at the lower voltage if unit is dual voltage rated, e.g. 208V for 208-230V units.
 Only two speed PSC fan (H & M) available on 575V units.
 Performance stated is at the rated power supply. Performance may vary as the power supply varies from the rated.
 All data is shown wet coil with clean 1" filter.
 All data is ran at 80 °F DB and 67 °F WB.
 CFM Tolerance is 7%.
 RPM/Watt Tolerance 10%.

Blower Performance Data – HB009

Blower Type	Speed Mode	Values	External Static Pressure (in. wg)										
			0.1	0.2	0.3	0.4	0.5	0.6	0.7	0.8	0.9	1.0	
PSC - Low Static	Low	CFM	340	322	300	260							
	Medium	CFM	390	360	320	290							260
	High	CFM	410	380	350	320							280

Airflow is controlled within 5% up to the Max ESP shown with wet coil.
 Do not select Dehumidification mode if HP CFM is on setting 1.
 Black areas denote ESP where operation is not recommended.
 PSC: Units factory shipped on medium speed. Other speeds require field selection.
 All airflow is rated and shown above at the lower voltage if unit is dual voltage rated, e.g. 208V for 208-230V units.
 Only two speed PSC fan (H & M) available on 575V units.
 Performance stated is at the rated power supply. Performance may vary as the power supply varies from the rated.
 All data is shown wet coil with clean 1" filter.
 All data is ran at 80 °F DB and 67 °F WB.
 CFM Tolerance is 7%.
 RPM/Watt Tolerance 10%.

Blower Performance Data – HB012

Blower Type	Speed Mode	Values	External Static Pressure (in. wg)									
			0.1	0.2	0.3	0.4	0.5	0.6	0.7	0.8	0.9	1.0
PSC - Low Static	Low	CFM	360	350	320	310						
	Medium	CFM	420	400	380	360	340					
	High	CFM	470	450	430	400	380	320				

Airflow is controlled within 5% up to the Max ESP shown with wet coil.
 Do not select Dehumidification mode if HP CFM is on setting 1.
 Black areas denote ESP where operation is not recommended.
 PSC: Units factory shipped on medium speed. Other speeds require field selection.
 All airflow is rated and shown above at the lower voltage if unit is dual voltage rated, e.g. 208V for 208-230V units.
 Only two speed PSC fan (H & M) available on 575V units.
 Performance stated is at the rated power supply. Performance may vary as the power supply varies from the rated.
 All data is shown wet coil with clean 1" filter.
 All data is ran at 80 °F DB and 67 °F WB.
 CFM Tolerance is 7%.
 RPM/Watt Tolerance 10%.

Blower Performance Data – HB015

Blower Type	Speed Mode	Values	External Static Pressure (in. wg)												
			0.1	0.2	0.3	0.4	0.5	0.6	0.7	0.8	0.9	1.0			
PSC - Low Static	Low	CFM	503	490	479	439									
	Medium	CFM	595	575	562	510	451								
	High	CFM				581	510	386							
PSC - High Static	Low	CFM	462	456	443	425	385								
	Medium	CFM	546	539	531	513	481	414							
	High	CFM						547	426						
ECM - Constant Volume	Minimum CFM	RPM		617	741	848	945	1028	1103	1171					
		Power (W)		36	52	68	84	99	114	129					
		CFM		375	375	375	375	375	375	375	375				
	Default CFM	RPM		661	767	859	944	1028	1107	1179	1247				
		Power (W)		55	74	90	108	127	147	166	186				
		CFM		525	525	525	525	525	525	525	525				
	Maximum CFM	RPM		586	695	795	882	963	1038	1111	1180	1248	1312		
		Power (W)		54	73	93	112	132	152	173	194	216	238		
		CFM		625	625	625	625	625	625	625	625	625	625	625	625

See ECM control section for details on setting airflow.
 Airflow is controlled within 5% up to the Max ESP shown with wet coil.
 Do not select Dehumidification mode if HP CFM is on setting 1.
 Black areas denote ESP where operation is not recommended.
 PSC: Units factory shipped on medium speed. Other speeds require field selection.
 All airflow is rated and shown above at the lower voltage if unit is dual voltage rated, e.g. 208V for 208-230V units.
 Only two speed PSC fan (H & M) available on 575V units.
 Performance stated is at the rated power supply. Performance may vary as the power supply varies from the rated.
 All data is shown wet coil with clean 1" filter.
 All data is ran at 80 °F DB and 67 °F WB.
 CFM Tolerance is 7%.
 RPM/Watt Tolerance 10%.

Blower Performance Data – HB018

Blower Type	Speed Mode	Values	External Static Pressure (in. wg)										
			0.1	0.2	0.3	0.4	0.5	0.6	0.7	0.8	0.9	1.0	
PSC - Low Static	Low	RPM	764	799	925	985							
		Power (W)	147	145	135	127							
		CFM	524	509	493	451							
	Medium	RPM	863	908	928	1022							
		Power (W)	170	167	161	143							
		CFM	611	588	564	514							
	High	RPM	972	992	1015	1032	1088						
		Power (W)	195	189	184	177	149						
		CFM	704	668	643	617	504						
PSC - High Static	Low	RPM	583										
		Power (W)	152										
		CFM	461										
	Medium	RPM	621	732	813	892	951						
		Power (W)	183	179	175	166	160						
		CFM	553	543	533	506	468						
	High	RPM	697	766	865	923	979	1027					
		Power (W)	227	222	212	206	192	177					
		CFM	670	661	645	628	587	534					
ECM - Constant Volume	Minimum CFM	RPM					1015	1096	1179	1275	1361		
		Power (W)					93	111	132	157	180		
		CFM					450	450	450	450	450		
	Default CFM	RPM	847	918	971	1095	1208	1297	1360	1418	1467		
		Power (W)	85	101	113	145	178	206	228	248	266		
		CFM	600	600	600	600	600	600	600	600	600		
	Maximum CFM	RPM	1036	1080	1131	1172	1213	1317	1406	1494			
		Power (W)	157	171	186	200	214	251	286	323			
		CFM	750	750	750	750	750	750	750	750			

See ECM control section for details on setting airflow. Airflow is controlled within 5% up to the Max ESP shown with wet coil.

Do not select Dehumidification mode if HP CFM is on setting 1. Black areas denote ESP where operation is not recommended.

PSC: Units factory shipped on medium speed. Other speeds require field selection.

All airflow is rated and shown above at the lower voltage if unit is dual voltage rated, e.g. 208V for 208-230V units.

Only two speed PSC fan (H & M) available on 575V units.

Performance stated is at the rated power supply. Performance may vary as the power supply varies from the rated.

All data is shown wet coil with clean 1" filter. All data is ran at 80 °F DB and 67 °F WB. CFM Tolerance is 7%. RPM/Watt Tolerance 10%.

Blower Performance Data – HB024

Blower Type	Speed Mode	Values	External Static Pressure (in. wg)																	
			0.1	0.2	0.3	0.4	0.5	0.6	0.7	0.8	0.9	1.0								
PSC - Low Static	Low	CFM	760	741	722	694	665	618												
	Medium	CFM	941	912	874	836	789	732						665						
	High	CFM				950	884	827						732	656					
PSC - High Static	Low	CFM	979		931	884	827	751						675						
	Medium	CFM				988	922	846						713						
	High	CFM				979	903	798						665						
ECM - Constant Volume	Minimum CFM	RPM	706	788	867	941	1013	1080						1143				1203	1259	1311
		Power (W)	71	89	107	124	141	159						177				195	213	230
		CFM	600	600	600	600	600	600						600				600	600	600
	Default CFM	RPM	882	943	1002	1059	1114	1168	1220	1271	1319	1366								
		Power (W)	145	165	185	205	225	245	266	285	306	326								
		CFM	800	800	800	800	800	800	800	800	800	800								
	Maximum CFM	RPM	1077	1122	1162	1200	1233	1263	1288	1310	1329	1343								
		Power (W)	284	300	315	332	351	364	379	396	412	428								
		CFM	1000	1000	1000	1000	1000	1000	1000	1000	1000	1000								

See ECM control section for details on setting airflow. Airflow is controlled within 5% up to the Max ESP shown with wet coil.
 Do not select Dehumidification mode if HP CFM is on setting 1.
 Black areas denote ESP where operation is not recommended.
 PSC: Units factory shipped on medium speed. Other speeds require field selection.
 All airflow is rated and shown above at the lower voltage if unit is dual voltage rated, e.g. 208V for 208-230V units.
 Only two speed PSC fan (H & M) available on 575V units.
 Performance stated is at the rated power supply. Performance may vary as the power supply varies from the rated.
 All data is shown wet coil with clean 1" filter. All data is ran at 80 °F DB and 67 °F WB.
 CFM Tolerance is 7%. RPM/Watt Tolerance 10%.

Blower Performance Data – HB030

Blower Type	Speed Mode	Values	External Static Pressure (in. wg)											
			0.1	0.2	0.3	0.4	0.5	0.6	0.7	0.8	0.9	1.0		
PSC - Low Static	Low	CFM	1017	979	931	884	827	751						
	Medium	CFM	1140	1093	1036	988	922	846						
	High	CFM			1102	1045	979	903						798
PSC - High Static	Low	CFM	979	941	912	865	798							
	Medium	CFM				1074	979						884	779
	High	CFM					1102						988	874
ECM - Constant Volume	Minimum CFM	RPM	872	928	990	1046	1096	1143	1192	1238	1282	1327		
		Power (W)	71	89	108	127	145	162	181	199	217	235		
		CFM	750	750	750	750	750	750	750	750	750	750		
	Default CFM	RPM	1131	1177	1218	1252	1295	1337	1381	1415				
		Power (W)	251	274	296	315	337	362	387	407				
		CFM	1000	1000	1000	1000	1000	1000	1000	1000				
	Maximum CFM	RPM	1260	1299	1334	1373	1403							
		Power (W)	388	410	431	453	471							
		CFM	1150	1150	1150	1150	1150							

See ECM control section for details on setting airflow. Airflow is controlled within 5% up to the Max ESP shown with wet coil.

Do not select Dehumidification mode if HP CFM is on setting 1.

Black areas denote ESP where operation is not recommended.

PSC: Units factory shipped on medium speed. Other speeds require field selection.

All airflow is rated and shown above at the lower voltage if unit is dual voltage rated, e.g. 208V for 208-230V units.

Only two speed PSC fan (H & M) available on 575V units.

Performance stated is at the rated power supply. Performance may vary as the power supply varies from the rated.

All data is shown wet coil with clean 1" filter. All data is ran at 80 °F DB and 67 °F WB.

CFM Tolerance is 7%. RPM/Watt Tolerance 10%.

Blower Performance Data – HB036

Blower Type	Speed Mode	Values	External Static Pressure (in. wg)										
			0.1	0.2	0.3	0.4	0.5	0.6	0.7	0.8	0.9	1.0	
PSC - Low Static	Low	CFM	970	960	951	941	902						
	Medium	CFM	1106	1096	1086	1067	1009	912					
	High	CFM	1436	1387	1329	1280	1174	1077	931				
PSC - High Static	Low	CFM	980	970	960	931	902						
	Medium	CFM	1300	1280	1261	1222	1193	1116	1038				
	High	CFM					1484	1426	1358	1251	1135	931	
ECM - Constant Volume	Minimum CFM	RPM	682	788	898	976	1043	1107	1170	1230	1297	1371	
		Power (W)	105	132	164	188	211	233	257	280	307	339	
		CFM	900	900	900	900	900	900	900	900	900	900	
	Default CFM	RPM	830	895	961	1054	1145	1209	1267	1321	1371	1419	
		Power (W)	205	232	261	303	349	382	415	446	475	505	
		CFM	1150	1150	1150	1150	1150	1150	1150	1150	1150	1150	
	Maximum CFM	RPM	1042	1040	1095	1149	1199	1273	1355	1420	1459	1493	
		Power (W)	406	403	438	474	511	564	629	680	692	691	
		CFM	1500	1500	1500	1500	1500	1500	1500	1500	1500	1500	

See ECM control section for details on setting airflow.
 Airflow is controlled within 5% up to the Max ESP shown with wet coil.
 Do not select Dehumidification mode if HP CFM is on setting 1.
 Black areas denote ESP where operation is not recommended.
 PSC: Units factory shipped on medium speed. Other speeds require field selection.
 All airflow is rated and shown above at the lower voltage if unit is dual voltage rated, e.g. 208V for 208-230V units.
 Only two speed PSC fan (H & M) available on 575V units.
 Performance stated is at the rated power supply. Performance may vary as the power supply varies from the rated.
 All data is shown wet coil with clean 1" filter.
 All data is ran at 80 °F DB and 67 °F WB.
 CFM Tolerance is 7%.
 RPM/Watt Tolerance 10%.

Blower Performance Data – HB041

Rated CFM	Min CFM	Motor Type	Motor Speed Setting	External Static Pressure (in. wg)										
				0.1	0.2	0.3	0.4	0.5	0.6	0.7	0.8	0.9	1.0	
1125	845	PSC	Low	CFM	1008	971								
			Medium	CFM	1142	1090	1023							
			High	CFM	1269	1198	1114	1018						

Airflow is controlled within 5% up to the Max ESP shown with wet coil.

Do not select Dehumidification mode if HP CFM is on setting 1.

Black areas denote ESP where operation is not recommended.

Units factory shipped on medium speed. Other speeds require field selection.

All airflow is rated and shown above at the lower voltage if unit is dual voltage rated, e.g. 208V for 208-230V units.

Only two speed fan (H & M) available on 575V units.

Performance stated is at the rated power supply. Performance may vary as the power supply varies from the rated.

All data is shown wet coil with clean 1" filter.

All data is ran at 80 °F DB and 67 °F WB.

CFM Tolerance is 7%.

RPM/Watt Tolerance 10%.

Blower Performance Data – HB042

Blower Type	Speed Mode	Values	External Static Pressure (in. wg)															
			0.1	0.2	0.3	0.4	0.5	0.6	0.7	0.8	0.9	1.0						
PSC - Low Static	Low	CFM	1074	1064														
	Medium	CFM	1368	1321									1273	1207	1131	1064		
	High	CFM	1501	1444									1378	1302	1226	1131		
PSC - High Static	Low	CFM																
	Medium	CFM											1302	1283	1254	1235	1188	1121
	High	CFM												1473	1444	1397	1378	1311
ECM - Constant Volume	Minimum CFM	RPM	786	855	920	985	1059	1125	1186	1240	1292	1346						
		Power (W)	154	177	200	224	252	280	306	331	355	383						
		CFM	1050	1050	1050	1050	1050	1050	1050	1050	1050	1050						
	Default CFM	RPM	997	1042	1094	1145	1193	1241	1292	1345	1400	1451						
		Power (W)	334	359	390	421	453	484	517	555	595	636						
		CFM	1400	1400	1400	1400	1400	1400	1400	1400	1400	1400						
	Maximum CFM	RPM	1224	1245	1282	1305	1327											
		Power (W)	658	674	703	700	697											
		CFM	1750	1750	1750	1750	1750											

See ECM control section for details on setting airflow.
 Airflow is controlled within 5% up to the Max ESP shown with wet coil.
 Do not select Dehumidification mode if HP CFM is on setting 1.
 Black areas denote ESP where operation is not recommended.
 PSC: Units factory shipped on medium speed. Other speeds require field selection.
 All airflow is rated and shown above at the lower voltage if unit is dual voltage rated, e.g. 208V for 208-230V units.
 Only two speed PSC fan (H & M) available on 575V units.
 Performance stated is at the rated power supply. Performance may vary as the power supply varies from the rated.
 All data is shown wet coil with clean 1" filter.
 All data is ran at 80 °F DB and 67 °F WB.
 CFM Tolerance is 7%.
 RPM/Watt Tolerance 10%.

Blower Performance Data – HB048

Blower Type	Speed Mode	Values	External Static Pressure (in. wg)												
			0.1	0.2	0.3	0.4	0.5	0.6	0.7	0.8	0.9	1.0			
PSC - Low Static	Low	CFM	1644	1606	1568	1492	1378	1264							
	Medium	CFM	1805	1767	1682	1625	1520	1340							
	High	CFM		1881	1815	1710	1596	1416						1216	1216
PSC - High Static	Low	CFM	1748	1720	1691	1644	1587	1520	1435	1311					
	Medium	CFM	1938	1891	1843	1796	1739	1691	1625	1539				1416	1254
	High	CFM				1957	1910	1862	1786	1701				1577	1435
ECM - Constant Volume	Minimum CFM	RPM	703	766	827	886	943	998	1051	1102	1150	1196			
		Power (W)	174	205	237	269	302	336	371	407	444	482			
		CFM	1200	1200	1200	1200	1200	1200	1200	1200	1200	1200	1200		
	Default CFM	RPM	833	884	932	986	1043	1089	1137	1191	1242	1293			
		Power (W)	287	329	369	412	455	495	536	578	620	662			
		CFM	1500	1500	1500	1500	1500	1500	1500	1500	1500	1500	1500		
	Maximum CFM	RPM	993	1038	1082	1129	1178	1220	1264	1311	1357	1402			
		Power (W)	562	616	669	724	781	832	885	940	994	1048			
		CFM	1900	1900	1900	1900	1900	1900	1900	1900	1900	1900	1900		

See ECM control section for details on setting airflow.

Airflow is controlled within 5% up to the Max ESP shown with wet coil.

Do not select Dehumidification mode if HP CFM is on setting 1.

Black areas denote ESP where operation is not recommended.

PSC: Units factory shipped on medium speed. Other speeds require field selection.

All airflow is rated and shown above at the lower voltage if unit is dual voltage rated, e.g. 208V for 208-230V units.

Only two speed PSC fan (H & M) available on 575V units.

Performance stated is at the rated power supply. Performance may vary as the power supply varies from the rated.

All data is shown wet coil with clean 1" filter.

All data is ran at 80 °F DB and 67 °F WB.

CFM Tolerance is 7%.

RPM/Watt Tolerance 10%.

Blower Performance Data – HB060

Blower Type	Speed Mode	Values	External Static Pressure (in. wg)										
			0.1	0.2	0.3	0.4	0.5	0.6	0.7	0.8	0.9	1.0	
PSC - Low Static	Low	CFM	1803	1774	1744	1695	1637	1568					
	Medium	CFM	1999	1950	1901	1852	1793	1744	1676	1588			
	High	CFM		1881	1815	1710	1596	1416	1216	1216			
PSC - High Static	Low	CFM	1882	1872	1852	1842	1813	1793	1764	1715	1666	1588	
	Medium	CFM	2107	2097	2038	1999	1980	1940	1891	1842	1460	1715	
	High	CFM	2342	2323	2293	2254	2195	2156	2087	2019	1940	1852	
ECM - Constant Volume	Minimum CFM	RPM	705	773	836	894	949	998	1044	1085	1121	1153	
		Power (W)	246	301	354	405	453	500	544	587	627	665	
		CFM	1500	1500	1500	1500	1500	1500	1500	1500	1500	1500	1500
	Default CFM	RPM	852	899	949	992	1031	1085	1136	1179	1225	1272	
		Power (W)	501	562	629	683	731	804	871	926	986	1047	
		CFM	1950	1950	1950	1950	1950	1950	1950	1950	1950	1950	1950
	Maximum CFM	RPM	995	1020	1044	1069	1094						
		Power (W)	885	896	901	916	937						
		CFM	2200	2200	2200	2200	2200						

See ECM control section for details on setting airflow.
 Airflow is controlled within 5% up to the Max ESP shown with wet coil.
 Do not select Dehumidification mode if HP CFM is on setting 1.
 Black areas denote ESP where operation is not recommended.
 PSC: Units factory shipped on medium speed. Other speeds require field selection.
 All airflow is rated and shown above at the lower voltage if unit is dual voltage rated, e.g. 208V for 208-230V units.
 Only two speed PSC fan (H & M) available on 575V units.
 Performance stated is at the rated power supply. Performance may vary as the power supply varies from the rated.
 All data is shown wet coil with clean 1" filter.
 All data is ran at 80 °F DB and 67 °F WB.
 CFM Tolerance is 7%.
 RPM/Watt Tolerance 10%.

Constant Volume ECM Control

The ECM Constant Volume (CV) blower motors (optional) are controlled directly by the DXM2 control board which converts thermostat inputs and CFM settings to signals used by the ECM-CV motor controller.

To take full advantage of the ECM-CV motor features a communicating service tool is used. The DXM2 control maintains a selectable operating airflow [CFM] for each heat pump operating mode. For each operating mode there are maximum and minimum airflow limits. See the ECM-CV Blower Performance tables for the maximum, minimum, and default operating airflows. Airflow levels are selected using the configuration menus of a configuration/diagnostic tool. The configuration menus allow the installer to independently select and adjust the operating airflow for each of the operating modes. Airflow can be selected in 25 CFM increments within the minimum and maximum limits shown in the ECM-CV Blower Performance Table. The blower operating modes include:

- First Stage Cooling (Y1 & O)
- First Stage Heating (Y1)
- Fan (G with no Y1, Y2, or W)

The ECM-CV motor includes “soft start” and “ramp down” features. The soft start feature is a gentle increase of motor rpm at blower start up. This creates a much quieter blower start cycle.

The ramp down feature allows the blower to slowly decrease rpm to a full stop at the end of each blower cycle. This creates a much quieter end to each blower cycle and adds overall unit efficiency. The ramp down feature is eliminated during an ESD (Emergency Shut Down) situation. When the DXM2 ESD input is activated, the blower and all other control outputs are immediately deactivated.

The ramp down feature (also known as the heating or cooling “Off Delay”) is field selectable by the installer. The allowable range is 0 to 255 seconds.

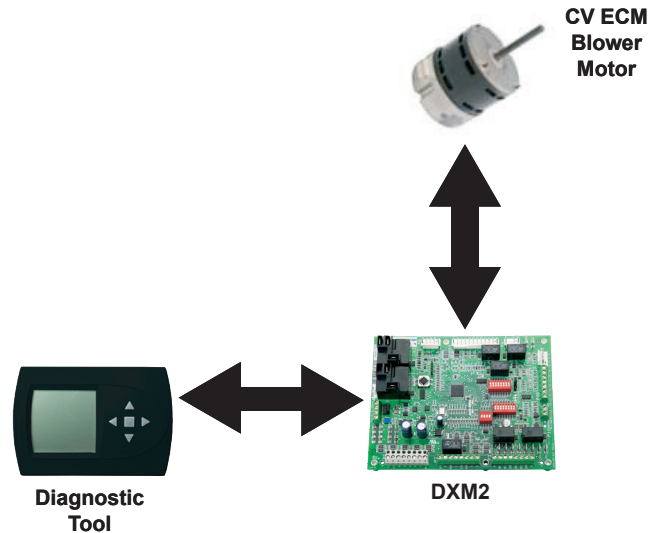

AIRFLOW SELECTION	
	CFM
HEAT STAGE 1	600
HEAT STAGE 2	750
AUXILIARY HEAT	850
EMERGENCY HEAT	850
COOL STAGE 1	525
COOL STAGE 2	700
COOL DEHUMID 1	425
COOL DEHUMID 2	550
CONTINUOUS FAN	350
HEAT OFF DELAY	60
COOL OFF DELAY	30
◀ PREVIOUS	NEXT ▶

Airflow Configuration Screen on Communicating Service Tool.

HB-Series Wiring Diagram Matrix

Unit Controller	Fan Motor	Water Side Economizer	208v/1 - 265v/1		208v/3	460v/3	575v/3
			006-012	015-060	024-060	024-060	041-060
CXM	PSC	None	96B0500N11		96B0500N21	96B0500N31	
		WSE	96B0452N15		96B0452N20	96B0452N30	
	CT ECM	None	96B0506N11		96B0506N21	96B0506N31	
		WSE	96B0455N11		96B0455N21	96B0455N31	
DXM2	PSC	None	96B0521N11		96B0521N21	96B0521N31	
		WSE	96B0476N11		96B0476N21	96B0476N31	
	CT ECM	None	96B0527N11		96B0527N21	96B0527N31	
		WSE	96B0478N11		96B0478N21	96B0478N31	
	CV ECM	None	96B0523N01	96B0523N11	96B0523N21	96B0523N31	
		WSE	96B0477N01	96B0477N11	96B0477N21	96B0477N31	
Auxiliary WD for LON			96B0147N17				
Auxiliary WD for MPC			96B0147N14				
Control Box Layouts			96B0500N00				

DIP Setting Table

DIP Setting Table - 99D0061N01

Note: Shade indicates DIP switch locating

HB DIGIT 9 = D, B + DXM2 WSE HB DIGIT 12 = 1,2,3,4 + DXM2 WSE		HB DIGIT 9 = M, K + DXM2 WSE + LON HB DIGIT 12 = 1,2,3,4 + DXM2 WSE + LON																																																																																																	
<table border="0"> <tr><td><input type="checkbox"/></td><td><input type="checkbox"/></td><td>1</td><td><input type="checkbox"/></td><td><input type="checkbox"/></td><td>1</td></tr> <tr><td><input type="checkbox"/></td><td><input checked="" type="checkbox"/></td><td>2</td><td><input checked="" type="checkbox"/></td><td><input type="checkbox"/></td><td>2</td></tr> <tr><td><input type="checkbox"/></td><td><input checked="" type="checkbox"/></td><td>3</td><td><input type="checkbox"/></td><td><input checked="" type="checkbox"/></td><td>3</td></tr> <tr><td><input type="checkbox"/></td><td><input checked="" type="checkbox"/></td><td>4</td><td><input type="checkbox"/></td><td><input checked="" type="checkbox"/></td><td>4</td></tr> <tr><td><input type="checkbox"/></td><td><input checked="" type="checkbox"/></td><td>5</td><td><input type="checkbox"/></td><td><input checked="" type="checkbox"/></td><td>5</td></tr> <tr><td><input type="checkbox"/></td><td><input checked="" type="checkbox"/></td><td>6</td><td><input type="checkbox"/></td><td><input checked="" type="checkbox"/></td><td>6</td></tr> <tr><td><input type="checkbox"/></td><td><input checked="" type="checkbox"/></td><td>7</td><td><input type="checkbox"/></td><td><input checked="" type="checkbox"/></td><td>7</td></tr> <tr><td><input type="checkbox"/></td><td><input checked="" type="checkbox"/></td><td>8</td><td><input type="checkbox"/></td><td><input checked="" type="checkbox"/></td><td>8</td></tr> </table>	<input type="checkbox"/>	<input type="checkbox"/>	1	<input type="checkbox"/>	<input type="checkbox"/>	1	<input type="checkbox"/>	<input checked="" type="checkbox"/>	2	<input checked="" type="checkbox"/>	<input type="checkbox"/>	2	<input type="checkbox"/>	<input checked="" type="checkbox"/>	3	<input type="checkbox"/>	<input checked="" type="checkbox"/>	3	<input type="checkbox"/>	<input checked="" type="checkbox"/>	4	<input type="checkbox"/>	<input checked="" type="checkbox"/>	4	<input type="checkbox"/>	<input checked="" type="checkbox"/>	5	<input type="checkbox"/>	<input checked="" type="checkbox"/>	5	<input type="checkbox"/>	<input checked="" type="checkbox"/>	6	<input type="checkbox"/>	<input checked="" type="checkbox"/>	6	<input type="checkbox"/>	<input checked="" type="checkbox"/>	7	<input type="checkbox"/>	<input checked="" type="checkbox"/>	7	<input type="checkbox"/>	<input checked="" type="checkbox"/>	8	<input type="checkbox"/>	<input checked="" type="checkbox"/>	8	<table border="0"> <tr><td><input type="checkbox"/></td><td><input type="checkbox"/></td><td>1</td><td><input type="checkbox"/></td><td><input type="checkbox"/></td><td>1</td></tr> <tr><td><input type="checkbox"/></td><td><input checked="" type="checkbox"/></td><td>2</td><td><input checked="" type="checkbox"/></td><td><input type="checkbox"/></td><td>2</td></tr> <tr><td><input type="checkbox"/></td><td><input checked="" type="checkbox"/></td><td>3</td><td><input type="checkbox"/></td><td><input checked="" type="checkbox"/></td><td>3</td></tr> <tr><td><input type="checkbox"/></td><td><input checked="" type="checkbox"/></td><td>4</td><td><input type="checkbox"/></td><td><input checked="" type="checkbox"/></td><td>4</td></tr> <tr><td><input type="checkbox"/></td><td><input checked="" type="checkbox"/></td><td>5</td><td><input type="checkbox"/></td><td><input checked="" type="checkbox"/></td><td>5</td></tr> <tr><td><input type="checkbox"/></td><td><input checked="" type="checkbox"/></td><td>6</td><td><input type="checkbox"/></td><td><input checked="" type="checkbox"/></td><td>6</td></tr> <tr><td><input type="checkbox"/></td><td><input checked="" type="checkbox"/></td><td>7</td><td><input type="checkbox"/></td><td><input checked="" type="checkbox"/></td><td>7</td></tr> <tr><td><input type="checkbox"/></td><td><input checked="" type="checkbox"/></td><td>8</td><td><input type="checkbox"/></td><td><input checked="" type="checkbox"/></td><td>8</td></tr> </table>	<input type="checkbox"/>	<input type="checkbox"/>	1	<input type="checkbox"/>	<input type="checkbox"/>	1	<input type="checkbox"/>	<input checked="" type="checkbox"/>	2	<input checked="" type="checkbox"/>	<input type="checkbox"/>	2	<input type="checkbox"/>	<input checked="" type="checkbox"/>	3	<input type="checkbox"/>	<input checked="" type="checkbox"/>	3	<input type="checkbox"/>	<input checked="" type="checkbox"/>	4	<input type="checkbox"/>	<input checked="" type="checkbox"/>	4	<input type="checkbox"/>	<input checked="" type="checkbox"/>	5	<input type="checkbox"/>	<input checked="" type="checkbox"/>	5	<input type="checkbox"/>	<input checked="" type="checkbox"/>	6	<input type="checkbox"/>	<input checked="" type="checkbox"/>	6	<input type="checkbox"/>	<input checked="" type="checkbox"/>	7	<input type="checkbox"/>	<input checked="" type="checkbox"/>	7	<input type="checkbox"/>	<input checked="" type="checkbox"/>	8	<input type="checkbox"/>	<input checked="" type="checkbox"/>	8		
<input type="checkbox"/>	<input type="checkbox"/>	1	<input type="checkbox"/>	<input type="checkbox"/>	1																																																																																														
<input type="checkbox"/>	<input checked="" type="checkbox"/>	2	<input checked="" type="checkbox"/>	<input type="checkbox"/>	2																																																																																														
<input type="checkbox"/>	<input checked="" type="checkbox"/>	3	<input type="checkbox"/>	<input checked="" type="checkbox"/>	3																																																																																														
<input type="checkbox"/>	<input checked="" type="checkbox"/>	4	<input type="checkbox"/>	<input checked="" type="checkbox"/>	4																																																																																														
<input type="checkbox"/>	<input checked="" type="checkbox"/>	5	<input type="checkbox"/>	<input checked="" type="checkbox"/>	5																																																																																														
<input type="checkbox"/>	<input checked="" type="checkbox"/>	6	<input type="checkbox"/>	<input checked="" type="checkbox"/>	6																																																																																														
<input type="checkbox"/>	<input checked="" type="checkbox"/>	7	<input type="checkbox"/>	<input checked="" type="checkbox"/>	7																																																																																														
<input type="checkbox"/>	<input checked="" type="checkbox"/>	8	<input type="checkbox"/>	<input checked="" type="checkbox"/>	8																																																																																														
<input type="checkbox"/>	<input type="checkbox"/>	1	<input type="checkbox"/>	<input type="checkbox"/>	1																																																																																														
<input type="checkbox"/>	<input checked="" type="checkbox"/>	2	<input checked="" type="checkbox"/>	<input type="checkbox"/>	2																																																																																														
<input type="checkbox"/>	<input checked="" type="checkbox"/>	3	<input type="checkbox"/>	<input checked="" type="checkbox"/>	3																																																																																														
<input type="checkbox"/>	<input checked="" type="checkbox"/>	4	<input type="checkbox"/>	<input checked="" type="checkbox"/>	4																																																																																														
<input type="checkbox"/>	<input checked="" type="checkbox"/>	5	<input type="checkbox"/>	<input checked="" type="checkbox"/>	5																																																																																														
<input type="checkbox"/>	<input checked="" type="checkbox"/>	6	<input type="checkbox"/>	<input checked="" type="checkbox"/>	6																																																																																														
<input type="checkbox"/>	<input checked="" type="checkbox"/>	7	<input type="checkbox"/>	<input checked="" type="checkbox"/>	7																																																																																														
<input type="checkbox"/>	<input checked="" type="checkbox"/>	8	<input type="checkbox"/>	<input checked="" type="checkbox"/>	8																																																																																														
HB DIGIT 9 = P, S + DXM2 WSE + MPC HB DIGIT 12 = 1,2,3,4 + DXM2 WSE + MPC		<table border="0"> <tr><td><input type="checkbox"/></td><td><input type="checkbox"/></td><td>1</td><td><input type="checkbox"/></td><td><input type="checkbox"/></td><td>1</td></tr> <tr><td><input type="checkbox"/></td><td><input checked="" type="checkbox"/></td><td>2</td><td><input checked="" type="checkbox"/></td><td><input type="checkbox"/></td><td>2</td></tr> <tr><td><input type="checkbox"/></td><td><input checked="" type="checkbox"/></td><td>3</td><td><input type="checkbox"/></td><td><input checked="" type="checkbox"/></td><td>3</td></tr> <tr><td><input type="checkbox"/></td><td><input checked="" type="checkbox"/></td><td>4</td><td><input type="checkbox"/></td><td><input checked="" type="checkbox"/></td><td>4</td></tr> <tr><td><input type="checkbox"/></td><td><input checked="" type="checkbox"/></td><td>5</td><td><input type="checkbox"/></td><td><input checked="" type="checkbox"/></td><td>5</td></tr> <tr><td><input checked="" type="checkbox"/></td><td><input type="checkbox"/></td><td>6</td><td><input type="checkbox"/></td><td><input checked="" type="checkbox"/></td><td>6</td></tr> <tr><td><input type="checkbox"/></td><td><input checked="" type="checkbox"/></td><td>7</td><td><input type="checkbox"/></td><td><input checked="" type="checkbox"/></td><td>7</td></tr> <tr><td><input type="checkbox"/></td><td><input checked="" type="checkbox"/></td><td>8</td><td><input type="checkbox"/></td><td><input checked="" type="checkbox"/></td><td>8</td></tr> </table>	<input type="checkbox"/>	<input type="checkbox"/>	1	<input type="checkbox"/>	<input type="checkbox"/>	1	<input type="checkbox"/>	<input checked="" type="checkbox"/>	2	<input checked="" type="checkbox"/>	<input type="checkbox"/>	2	<input type="checkbox"/>	<input checked="" type="checkbox"/>	3	<input type="checkbox"/>	<input checked="" type="checkbox"/>	3	<input type="checkbox"/>	<input checked="" type="checkbox"/>	4	<input type="checkbox"/>	<input checked="" type="checkbox"/>	4	<input type="checkbox"/>	<input checked="" type="checkbox"/>	5	<input type="checkbox"/>	<input checked="" type="checkbox"/>	5	<input checked="" type="checkbox"/>	<input type="checkbox"/>	6	<input type="checkbox"/>	<input checked="" type="checkbox"/>	6	<input type="checkbox"/>	<input checked="" type="checkbox"/>	7	<input type="checkbox"/>	<input checked="" type="checkbox"/>	7	<input type="checkbox"/>	<input checked="" type="checkbox"/>	8	<input type="checkbox"/>	<input checked="" type="checkbox"/>	8	<table border="0"> <tr><td><input type="checkbox"/></td><td><input type="checkbox"/></td><td>1</td><td><input type="checkbox"/></td><td><input type="checkbox"/></td><td>1</td></tr> <tr><td><input type="checkbox"/></td><td><input checked="" type="checkbox"/></td><td>2</td><td><input checked="" type="checkbox"/></td><td><input type="checkbox"/></td><td>2</td></tr> <tr><td><input type="checkbox"/></td><td><input checked="" type="checkbox"/></td><td>3</td><td><input type="checkbox"/></td><td><input checked="" type="checkbox"/></td><td>3</td></tr> <tr><td><input type="checkbox"/></td><td><input checked="" type="checkbox"/></td><td>4</td><td><input type="checkbox"/></td><td><input checked="" type="checkbox"/></td><td>4</td></tr> <tr><td><input type="checkbox"/></td><td><input checked="" type="checkbox"/></td><td>5</td><td><input type="checkbox"/></td><td><input checked="" type="checkbox"/></td><td>5</td></tr> <tr><td><input checked="" type="checkbox"/></td><td><input type="checkbox"/></td><td>6</td><td><input type="checkbox"/></td><td><input checked="" type="checkbox"/></td><td>6</td></tr> <tr><td><input type="checkbox"/></td><td><input checked="" type="checkbox"/></td><td>7</td><td><input type="checkbox"/></td><td><input checked="" type="checkbox"/></td><td>7</td></tr> <tr><td><input type="checkbox"/></td><td><input checked="" type="checkbox"/></td><td>8</td><td><input type="checkbox"/></td><td><input checked="" type="checkbox"/></td><td>8</td></tr> </table>	<input type="checkbox"/>	<input type="checkbox"/>	1	<input type="checkbox"/>	<input type="checkbox"/>	1	<input type="checkbox"/>	<input checked="" type="checkbox"/>	2	<input checked="" type="checkbox"/>	<input type="checkbox"/>	2	<input type="checkbox"/>	<input checked="" type="checkbox"/>	3	<input type="checkbox"/>	<input checked="" type="checkbox"/>	3	<input type="checkbox"/>	<input checked="" type="checkbox"/>	4	<input type="checkbox"/>	<input checked="" type="checkbox"/>	4	<input type="checkbox"/>	<input checked="" type="checkbox"/>	5	<input type="checkbox"/>	<input checked="" type="checkbox"/>	5	<input checked="" type="checkbox"/>	<input type="checkbox"/>	6	<input type="checkbox"/>	<input checked="" type="checkbox"/>	6	<input type="checkbox"/>	<input checked="" type="checkbox"/>	7	<input type="checkbox"/>	<input checked="" type="checkbox"/>	7	<input type="checkbox"/>	<input checked="" type="checkbox"/>	8	<input type="checkbox"/>	<input checked="" type="checkbox"/>	8
<input type="checkbox"/>	<input type="checkbox"/>	1	<input type="checkbox"/>	<input type="checkbox"/>	1																																																																																														
<input type="checkbox"/>	<input checked="" type="checkbox"/>	2	<input checked="" type="checkbox"/>	<input type="checkbox"/>	2																																																																																														
<input type="checkbox"/>	<input checked="" type="checkbox"/>	3	<input type="checkbox"/>	<input checked="" type="checkbox"/>	3																																																																																														
<input type="checkbox"/>	<input checked="" type="checkbox"/>	4	<input type="checkbox"/>	<input checked="" type="checkbox"/>	4																																																																																														
<input type="checkbox"/>	<input checked="" type="checkbox"/>	5	<input type="checkbox"/>	<input checked="" type="checkbox"/>	5																																																																																														
<input checked="" type="checkbox"/>	<input type="checkbox"/>	6	<input type="checkbox"/>	<input checked="" type="checkbox"/>	6																																																																																														
<input type="checkbox"/>	<input checked="" type="checkbox"/>	7	<input type="checkbox"/>	<input checked="" type="checkbox"/>	7																																																																																														
<input type="checkbox"/>	<input checked="" type="checkbox"/>	8	<input type="checkbox"/>	<input checked="" type="checkbox"/>	8																																																																																														
<input type="checkbox"/>	<input type="checkbox"/>	1	<input type="checkbox"/>	<input type="checkbox"/>	1																																																																																														
<input type="checkbox"/>	<input checked="" type="checkbox"/>	2	<input checked="" type="checkbox"/>	<input type="checkbox"/>	2																																																																																														
<input type="checkbox"/>	<input checked="" type="checkbox"/>	3	<input type="checkbox"/>	<input checked="" type="checkbox"/>	3																																																																																														
<input type="checkbox"/>	<input checked="" type="checkbox"/>	4	<input type="checkbox"/>	<input checked="" type="checkbox"/>	4																																																																																														
<input type="checkbox"/>	<input checked="" type="checkbox"/>	5	<input type="checkbox"/>	<input checked="" type="checkbox"/>	5																																																																																														
<input checked="" type="checkbox"/>	<input type="checkbox"/>	6	<input type="checkbox"/>	<input checked="" type="checkbox"/>	6																																																																																														
<input type="checkbox"/>	<input checked="" type="checkbox"/>	7	<input type="checkbox"/>	<input checked="" type="checkbox"/>	7																																																																																														
<input type="checkbox"/>	<input checked="" type="checkbox"/>	8	<input type="checkbox"/>	<input checked="" type="checkbox"/>	8																																																																																														
		S1	S2	S1	S2																																																																																														

CXM Controls

CXM Control - For detailed control information, see CXM Application, Operation and Maintenance (AOM) manual (part # 97B0003N12).

Field Selectable Inputs - Test mode: Test mode allows the service technician to check the operation of the control in a timely manner. At board, momentarily shorting the test terminals or externally, momentarily push test button (See Fig 22), the CXM control enters a 20 minute test mode period in which all time delays are sped up 15 times. Upon entering test mode, the status LED will flash a code representing the last fault. For diagnostic ease at the thermostat, the alarm relay will also cycle during test mode. The alarm relay will cycle on and off similar to the status LED to indicate a code representing the last fault, at the thermostat. Test mode can be exited by shorting the test terminals or holding button for 3 seconds.

Retry Mode: If the control is attempting a retry of a fault, the status LED will slow flash (slow flash = one flash every 2 seconds) to indicate the control is in the process of retrying.

Field Configuration Options - Note: In the following field configuration options, jumper wires should be clipped ONLY when power is removed from the CXM control.

Water coil low temperature limit setting: Jumper 3 (JW3-LT1 Low Temp) provides field selection of temperature limit setting for LT1 of 30°F or 10°F [-1°F or -12°C] (refrigerant temperature).

Not Clipped = 30°F [-1°C]. Clipped = 10°F [-12°C].

Air coil low temperature limit setting: Jumper 2 (JW2-LT2 Low Temp) provides field selection of temperature limit setting for LT2 of 30°F or 10°F [-1°F or -12°C] (refrigerant temperature). **Note: This jumper should only be clipped under extenuating circumstances, as recommended by the factory.**

Not Clipped = 30°F [-1°C]. Clipped = 10°F [-12°C].

Alarm relay setting: Jumper 1 (JW1-AL2 Dry) provides field selection of the alarm relay terminal AL2 to be jumpered to 24VAC or to be a dry contact (no connection).

Not Clipped = AL2 connected to R. Clipped = AL2 dry contact (no connection).

DIP Switches - Note: In the following field configuration options, DIP switches should only be changed when power is removed from the CXM control.

DIP switch 1: Not applicable.
On = Enabled. Off = Disabled.

DIP switch 2: Stage 2 Selection - provides selection of whether compressor has an “on” delay. If set to stage 2, the compressor will have a 3 second delay before energizing. Also, if set for stage 2, the alarm relay will NOT cycle during test mode.

On = Stage 1. Off = Stage 2

DIP switch 3: Not Used.

DIP switch 4: DDC Output at EH2 - provides selection for DDC operation. If set to “DDC Output at EH2,” the EH2 terminal will continuously output the last fault code of the controller. If set to “EH2 normal,” EH2 will operate as standard electric heat output.

On = EH2 Normal. Off = DDC Output at EH2.

Note: Some CXM controls only have a 2 position DIP switch package. If this is the case, this option can be selected by clipping the jumper which is in position 4 of SW1.

Jumper not clipped = EH2 Normal. Jumper clipped = DDC Output at EH2.

DIP switch 5: Factory Setting - Normal position is “On.” Do not change selection unless instructed to do so by the factory.

Table 4: LED and Alarm Relay Operations

Description of Operation	LED	Alarm
Normal Mode	ON	Open
Normal Mode w/UPS Warning	ON	Cycle (Closed 5 seconds, Open 25 seconds)
CXM is non-functional	OFF	Open
Fault Retry	Slow Flash	Open
Lockout	Fast Flash	Closed
Over/Under Voltage Shutdown	Slow Flash	Open (Closed after 15 Minutes)
Test Mode - No Fault in Memory	Flashing Code 1	Cycling Code 1
Test Mode - HP Fault in Memory	Flashing Code 2	Cycling Code 2
Test Mode - LP Fault in Memory	Flashing Code 3	Cycling Code 3
Test Mode - LT1 Fault in Memory	Flashing Code 4	Cycling Code 4
Test Mode - LT2 Fault in Memory	Flashing Code 5	Cycling Code 5
Test Mode - CO Fault in Memory	Flashing Code 6	Cycling Code 6
Test Mode - Over/Under Shutdown in Memory	Flashing Code 7	Cycling Code 7
Test Mode - UPS in Memory	Flashing Code 8	Cycling Code 8
Test Mode - Swapped Thermistor	Flashing Code 9	Cycling Code 9

- Slow Flash = 1 flash every 2 seconds
- Fast Flash = 2 flashes every 1 second
- Flash code 2 = 2 quick flashes, 10 second pause, 2 quick flashes, 10 second pause, etc.
- On pulse 1/3 second; off pulse 1/3 second

CAUTION!

CAUTION! Do not restart units without inspection and remedy of faulting condition. Equipment damage may occur.

DXM2 Controls

DXM2 Control - For detailed control information, see DXM2 Application, Operation and Maintenance (AOM) manual (part # 97B0003N15).

Field Selectable Inputs - Test mode: Test mode allows the service technician to check the operation of the control in a timely manner. By momentarily pressing the TEST pushbutton, the DXM2 control enters a 20 minute test mode period in which all time delays are sped up 15 times. Upon entering test mode, the status LED display will change, either flashing rapidly to indicate the control is in the test mode, or displaying a numeric flash code representing the current airflow if an ECM blower is connected and operating. For diagnostic ease at conventional thermostats, the alarm relay will also cycle during test mode. The alarm relay will cycle on and off similar to the fault LED to indicate a code representing the last fault, at the thermostat. Test mode can be exited by pressing the TEST pushbutton for 3 seconds.

Retry Mode - If the control is attempting a retry of a fault, the fault LED will slow flash (slow flash = one flash every 2 seconds) to indicate the control is in the process of retrying.

Field Configuration Options - Note: In the following field configuration options, jumper wires should be clipped ONLY when power is removed from the DXM2 control.

Water coil low temperature limit setting: Jumper 3 (JW3-LT1 Low Temp) provides field selection of temperature limit setting for LT1 of 30°F or 10°F [-1°F or -12°C] (refrigerant temperature).

Not Clipped = 30°F [-1°C]. Clipped = 10°F [-12°C].

Alarm relay setting: Jumper 1 (JW1-AL2 Dry) provides field selection of the alarm relay terminal AL2 to be jumpered to 24VAC or to be a dry contact (no connection). Not Clipped = AL2 connected to R. Clipped = AL2 dry contact (no connection).

JUMPERS (Set at Factory)

A0-2: Configure Modulating Valve or Variable-Speed Pump

Set A0-2 jumper to "IOV" if using Internal Modulating Motorized Valve or "PMW" if using Internal Variable-Speed Pump.

DIP Switches - Note: In the following field configuration options, DIP switches should only be changed when power is removed from the DXM2 control.

DIP Package #1 (S1) - DIP Package #1 has 8 switches and provides the following setup selections:

1.1 - Not applicable.

On = Enabled. Off = Disabled.

1.2 - Compressor relay staging operation: DIP 1.2 provides selection of compressor relay staging operation. The compressor relay can be selected to turn on with a stage 1 or stage 2 call from the thermostat. This is used with dual stage units (2 compressors where 2 DXM2 controls are being used) or with master/slave applications. In master/slave applications, each compressor and fan will stage according to its appropriate DIP 1.2 setting. If set to stage 2, the compressor will have a 3 second on-delay before energizing during a Stage 2 demand. Also, if set for stage 2, the alarm relay will NOT cycle during test mode.

On = Stage 1. Off = Stage 2.

1.3 - Thermostat type (heat pump or heat/cool): DIP 1.3 provides selection of thermostat type. Heat pump or heat/cool thermostats can be selected. When in heat/cool mode, Y1 is the input call for cooling stage 1; Y2 is the input call for cooling stage 2; W1 is the input call for heating stage 1; and O/W2 is the input call for heating stage 2. In heat pump mode, Y1 is the input call for compressor stage 1; Y2 is the input call for compressor stage 2; W1 is the input call for heating stage 3 or emergency heat; and O/W2 is the input call for reversing valve (heating or cooling, depending upon DIP 1.4).

On = Heat Pump. Off = Heat/Cool.

1.4 - Thermostat type (O/B): DIP 1.4 provides selection of thermostat type for reversing valve activation. Heat pump thermostats with "O" output (reversing valve energized for cooling) or "B" output (reversing valve energized for heating) can be selected with DIP 1.4.

On = HP stat with "O" output for cooling. Off = HP stat with "B" output for heating.

1.5 - Dehumidification mode: DIP 1.5 provides selection of normal or dehumidification fan mode. In dehumidification mode, the fan speed relay will remain off during cooling stage 2. In normal mode, the fan speed relay will turn on during cooling stage 2.

On = Normal fan mode. Off = Dehumidification mode.

DXM2 Controls, Cont'd.

1.6 – DDC output at EH2: DIP 1.6 provides selection for DDC operation. If set to “DDC Output at EH2,” the EH2 terminal will continuously output the last fault code of the controller. If set to “EH2 normal,” EH2 will operate as standard electric heat output.

On = EH2 Normal. Off = DDC Output at EH2.

1.7– Boilerless operation: DIP 1.7 provides selection of boilerless operation. In boilerless mode, the compressor is only used for heating when LT1 is above the temperature specified by the setting of DIP 1.8. Below DIP 1.8 setting, the compressor is not used and the control goes into emergency heat mode, staging on EH1 and EH2 to provide heating.

On = normal. Off = Boilerless operation.

1.8 – Boilerless changeover temperature: DIP 1.8 provides selection of boilerless changeover temperature setpoint. Note that the LT1 thermistor is sensing refrigerant temperature between the coaxial heat exchanger and the expansion device (TXV). Therefore, the 50°F [10°C] setting is not 50°F [10°C] water, but approximately 60°F [16°C] EWT.

On = 50°F [10°C]. Off = 40°F [16°C].

DIP Package #2 (S2) – A combination of dip switches **2.1, 2.2, 2.3, and 2.4, 2.5, 2.6** deliver configuration of ACC1 and ACC2 relay options respectively. See Table 5b for description and functionality.

2.7 – Auto dehumidification fan mode or high fan mode: DIP 2.7 provides selection of auto dehumidification fan mode or high fan mode. In auto dehumidification mode, the fan speed relay will remain off during cooling stage 2 IF the H input is active. In high fan mode, the fan enable and fan speed relays will turn on when the H input is active.

On = Auto dehumidification mode (default). Off = High fan mode.

2.8 – Special factory selection: DIP 2.8 provides special factory selection. Normal position is “On”. Do not change selection unless instructed to do so by the factory.

Table 5b: Accessory DIP Switch Settings

DIP 2.1	DIP 2.2	DIP 2.3	ACC1 Relay Option
On	On	On	Cycle with fan
Off	On	On	Digital NSB
On	Off	On	Water Valve - slow opening
On	On	Off	OAD
Off	Off	Off	Reheat Option - Humidistat
Off	On	Off	Reheat Option - Dehumidistat
DIP 2.4	DIP 2.5	DIP 2.6	ACC2 Relay Option
On	On	On	Cycle with compressor
Off	On	On	Digital NSB
On	Off	On	Water Valve - slow opening
On	On	Off	OAD

All other DIP combinations are invalid

DIP Package #3 (S3)

– DIP Package #3 has 4 switches and provides the following setup and operating selections:

3.1 – Communications configuration: DIP 3.1 provides selection of the DXM2 operation in a communicating system. The DXM2 may operate as the Master of certain network configurations. In most configurations the DXM2 will operate as a master device.

On = Communicating Master device (default). Off = communicating Slave device.

3.2 – HWG Test Mode: DIP 3.2 provides forced operation of the HWG pump output, activating the HWG pump output for up to five minutes.

On = HWG test mode. Off = Normal HWG mode (default).

3.3 – HWG Temperature: DIP 3.3 provides the selection of the HWG operating setpoint.

On = 150°F [66°C]. Off = 125°F [52°C] (default).

3.4 – HWG Status: DIP 3.4 provides HWG operation control.

On = HWG mode enabled. Off = HWG mode disabled (default).

❑ CAUTION! ❑

CAUTION! Do not restart units without inspection and remedy of faulting condition. Equipment damage may occur.

DXM2 Controls, Cont'd.

Table 5c: LED and Alarm Relay Output Table

DMX2 CONTROLLER FAULT CODES			
DMX2 Fault and Status LED Operation with Test Mode Not Active	Fault LED (Red)	Status LED (Green)	Alarm Relay
DXM2 Is Non-Functional	Off	Off	Open
Normal Operation - No Active Communications	On	On	Open
Normal Operation - With Active Communications	Very Slow Flash	ON	Open
Control Is Currently In Fault Retry Mode	Slow Flash	-	Open
Control Is Currently Locked Out	Fast Flash	-	Closed
Control Is Currently In An Over/ Under Voltage Condition	Slow Flash	-	Open (Closed After 15 min)
Hot Water Mode Active	-	Slow Flash	Open
(NSB) Night Setback Condition Recognized	-	Flashing Code 2	-
(ESD) Emergency Shutdown Condition Recognized	-	Flashing Code 3	-
Invalid Thermostat Input Combination	-	Flashing Code 4	-
High Hot Water Temperature Lockout Active	-	Flashing Code 5	-
Hot Water Mode Sensor Fault Active	-	Flashing Code 6	-
DMX2 Fault LED and Status Operation with Test Mode Active	Fault LED (Red)	Status LED (Green)	Alarm Relay
No Fault Since Power Up In Memory	Flashing Code 1	-	Cycling Code 1
High Pressure Fault In Memory	Flashing Code 2	-	Cycling Code 2
Low Pressure Fault In Memory	Flashing Code 3	-	Cycling Code 3
Low Temperature Protection 1 In Fault Memory	Flashing Code 4	-	Cycling Code 4
Low Temperature Protection 2 In Fault Memory	Flashing Code 5	-	Cycling Code 5
Condensate Overflow Fault In Memory	Flashing Code 6	-	Cycling Code 6
Over/Under Voltage Shutdown In Memory	Flashing Code 7	-	Cycling Code 7
UPS Warning In Memory	Flashing Code 8	-	Cycling Code 8
UPT Fault In Memory	Flashing Code 9	-	Cycling Code 9
ECM Air Flow Fault In Memory	Flashing Code 10	-	Cycling Code 10
Test Mode Active With No ECM Connected Or Operating	-	Fast Flash	-
Test Mode Active With ECM Operating	-	Flashing ECM Airflow	-

- Fast Flash = 2 flashes every 1 second.
- Slow Flash = 1 flash every 2 seconds.
- Very Slow Flash = 1 flash every 5 seconds.
- Numeric Codes = On pulse 1/3 second; Off pulse 1/3 second followed by a 10 second delay.
- ECM Airflow = 1 flash per 100 CFM; On pulse 1/3 second followed by a 10 second delay.
- Alarm Relay Open = alarm signal off; Alarm Relay Closed = alarm signal on.

DXM2 Controls, Cont'd.

DXM2 Control Start-up Operation – The control will not operate until all inputs and safety controls are checked for normal conditions. The compressor will have a 5 minute anti-short cycle delay at power-up. The first time after power-up that there is a call for compressor, the compressor will follow a 5 to 80 second random start delay. After the random start delay and anti-short cycle delay, the compressor relay will be energized. On all subsequent compressor calls, the random start delay is omitted.

Table 5d: Unit Operation

Conventional T-stat signal (Non-Communicating)	Unit
	ECM fan
G	Fan only
G, Y1	Stage 1 heating ¹
G, Y1, Y2	Stage 2 heating ¹
G, Y1, Y2, W	Stage 3 heating ¹
G, W	Emergency heat
G, Y1, O	Stage 1 cooling ²
G, Y1, Y2, O	Stage 2 cooling ²

¹ Stage 1 = 1st stage compressor, 1st stage fan operation
 Stage 2 = 2nd stage compressor, 2nd stage fan operation
 Stage 3 = 2nd stage compressor, auxiliary electric heat, 3rd stage fan operation
² Stage 1 = 1st stage compressor, 1st stage fan operation, reversing valve
 Stage 2 = 2nd stage compressor, 2nd stage fan operation, reversing valve

Figure 22: Test Mode Button

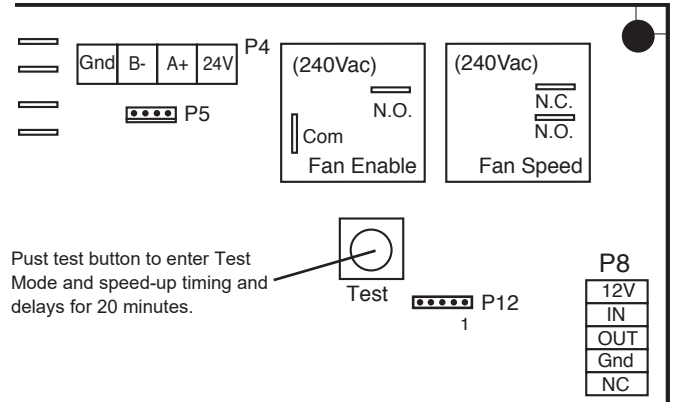

DXM2 Controls, Cont'd.

Table 5e: Nominal Resistance at Various Temperatures

Temp (°C)	Temp (°F)	Resistance (kOhm)	Temp (°C)	Temp (°F)	Resistance (kOhm)
-17.8	0.0	85.34	55	131.0	2.99
-17.5	0.5	84.00	56	132.8	2.88
-16.9	1.5	81.38	57	134.6	2.77
-12	10.4	61.70	58	136.4	2.67
-11	12.2	58.40	59	138.2	2.58
-10	14.0	55.30	60	140.0	2.49
-9	15.8	52.38	61	141.8	2.40
-8	17.6	49.64	62	143.6	2.32
-7	19.4	47.05	63	145.4	2.23
-6	21.2	44.61	64	147.2	2.16
-5	23.0	42.32	65	149.0	2.08
-4	24.8	40.15	66	150.8	2.01
-3	26.6	38.11	67	152.6	1.94
-2	28.4	36.18	68	154.4	1.88
-1	30.2	34.37	69	156.2	1.81
0	32.0	32.65	70	158.0	1.75
1	33.8	31.03	71	159.8	1.69
2	35.6	29.50	72	161.6	1.64
3	37.4	28.05	73	163.4	1.58
4	39.2	26.69	74	165.2	1.53
5	41.0	25.39	75	167.0	1.48
6	42.8	24.17	76	168.8	1.43
7	44.6	23.02	77	170.6	1.39
8	46.4	21.92	78	172.4	1.34
9	48.2	20.88	79	174.2	1.30
10	50.0	19.90	80	176.0	1.26
11	51.8	18.97	81	177.8	1.22
12	53.6	18.09	82	179.6	1.18
13	55.4	17.26	83	181.4	1.14
14	57.2	16.46	84	183.2	1.10
15	59.0	15.71	85	185.0	1.07
16	60.8	15.00	86	186.8	1.04
17	62.6	14.32	87	188.6	1.01
18	64.4	13.68	88	190.4	0.97
19	66.2	13.07	89	192.2	0.94
20	68.0	12.49	90	194.0	0.92
21	69.8	11.94	91	195.8	0.89
22	71.6	11.42	92	197.6	0.86
23	73.4	10.92	93	199.4	0.84
24	75.2	10.45	94	201.2	0.81
25	77.0	10.00	95	203.0	0.79
26	78.8	9.57	96	204.8	0.76
27	80.6	9.16	97	206.6	0.74
28	82.4	8.78	98	208.4	0.72
29	84.2	8.41	99	210.2	0.70
30	86.0	8.06	100	212.0	0.68
31	87.8	7.72	101	213.8	0.66
32	89.6	7.40	102	215.6	0.64
33	91.4	7.10	103	217.4	0.62
34	93.2	6.81	104	219.2	0.60
35	95.0	6.53	105	221.0	0.59
36	96.8	6.27	106	222.8	0.57
37	98.6	6.01	107	224.6	0.55
38	100.4	5.77	108	226.4	0.54
39	102.2	5.54	109	228.2	0.52
40	104.0	5.33	110	230.0	0.51
41	105.8	5.12	111	231.8	0.50
42	107.6	4.92	112	233.6	0.48
43	109.4	4.72	113	235.4	0.47
44	111.2	4.54	114	237.2	0.46
45	113.0	4.37	115	239.0	0.44
46	114.8	4.20	116	240.8	0.43
47	116.6	4.04	117	242.6	0.42
48	118.4	3.89	118	244.4	0.41
49	120.2	3.74	119	246.2	0.40
50	122.0	3.60	120	248.0	0.39
51	123.8	3.47	121	249.8	0.38
52	125.6	3.34	122	251.6	0.37
53	127.4	3.22	123	253.4	0.36
54	129.2	3.10			

DXM2 Thermostat Details

Thermostat Compatibility – Most heat pump and heat/cool thermostats can be used with the DXM2.

Anticipation Leakage Current – Maximum leakage current for “Y1” is 50 mA and for “W” is 20mA. Triacs can be used if leakage current is less than above. Thermostats with anticipators can be used if anticipation current is less than that specified above.

Thermostat Signals -

- “Y1, Y2, W1, O” and “G” have a 1 second recognition time when being activated or being removed.
- “R” and “C” are from the transformer.
- “AL1” and “AL2” originate from the Alarm Relay.
- “A+” and “B-” are for a communicating thermostat.

Safety Features – CXM and DXM2 Controls

Safety Features – CXM/DXM2 Control

The safety features below are provided to protect the compressor, heat exchangers, wiring, and other components from damage caused by operation outside of design conditions.

Anti-short cycle protection: The control features a 5 minute anti-short cycle protection for the compressor.

Note: The 5 minute anti-short cycle also occurs at power up.

Random start: The control features a random start upon power up of 5-80 seconds.

Fault Retry: In Fault Retry mode, the Status LED begins slowly flashing to signal that the control is trying to recover from a fault input. The control will stage off the outputs and then “try again” to satisfy the thermostat input call. Once the thermostat input call is satisfied, the control will continue on as if no fault occurred. If 3 consecutive faults occur without satisfying the thermostat input call, the control will go into “lockout” mode. The last fault causing the lockout will be stored in memory and can be viewed at the “fault” LED (DXM2 board) or by going into test mode (CXM board). **Note: LT1/LT2 faults are factory set at only one try.**

Lockout: In lockout mode, the status LED will begin fast flashing. The compressor relay is turned off immediately. Lockout mode can be “soft” reset by turning off the thermostat (or satisfying the call). A “soft” reset keeps the fault in memory but resets the control. A “hard” reset (disconnecting power to the control) resets the control and erases fault memory.

Lockout with emergency heat: While in lockout mode, if W becomes active (CXM), emergency heat mode will occur. If DXM2 is configured for heat pump thermostat type (DIP 1.3), emergency heat will become active if O/W2 is energized.

High pressure switch: When the high pressure switch opens due to high refrigerant pressures, the compressor relay is de-energized immediately since the high pressure switch is in series with the compressor contactor coil. The high pressure fault recognition is immediate (does not delay for 30 continuous seconds before de-energizing the compressor).

High pressure lockout code = 2

Example: 2 quick flashes, 10 sec pause, 2 quick flashes, 10 sec. pause, etc.

Low pressure switch: The low pressure switch must be open and remain open for 30 continuous seconds during “on” cycle to be recognized as a low pressure fault. If the low pressure switch is open for 30 seconds prior to compressor power up it will be considered a low pressure (loss of charge) fault. The low pressure switch input is bypassed for the initial 120 seconds of a compressor run cycle.

Low pressure lockout code = 3

Water coil low temperature (LT1): The LT1 thermistor temperature must be below the selected low temperature limit setting for 30 continuous seconds during a compressor run cycle to be recognized as a LT1 fault. The LT1 input is bypassed for the initial 120 seconds of a compressor run cycle. LT1 is set at the factory for one try. Therefore, the control will go into lockout mode once the LT1 fault has occurred.

LT1 lockout code = 4

Air coil low temperature (LT2): The LT2 thermistor temperature must be below the selected low temperature limit setting for 30 continuous seconds during a compressor run cycle to be recognized as a LT2 fault. The LT2 input is bypassed for the initial 60 seconds of a compressor run cycle. LT2 is set at the factory for one try. Therefore, the control will go into lockout mode once the LT2 fault has occurred.

LT2 lockout code = 5

Condensate overflow: The condensate overflow sensor must sense overflow level for 30 continuous seconds to be recognized as a CO fault. Condensate overflow will be monitored at all times.

CO lockout code = 6

Over/under voltage shutdown: An over/under voltage condition exists when the control voltage is outside the range of 19VAC to 30VAC. Over/under voltage shut down is a self-resetting safety. If the voltage comes back within range for at least 0.5 seconds, normal operation is restored. This is not considered a fault or lockout. If the CXM/DXM2 is in over/under voltage shutdown for 15 minutes, the alarm relay will close.

Over/under voltage shut down code = 7

Safety Features – CXM and DXM2 Controls, Cont'd.

Unit Performance -UPS: The UPS feature indicates when the heat pump is operating inefficiently. A UPS condition exists when:

- a. In heating mode with compressor energized, LT2 is greater than 125°F [52°C] for 30 continuous seconds, or:
- b. In cooling mode with compressor energized, LT1 is greater than 125°F [52°C] for 30 continuous seconds, or:
- c. In cooling mode with compressor energized, LT2 is less than 40°F [4.5°C] for 30 continuous seconds.

If a UPS condition occurs, the control will immediately go to UPS warning. The status LED will remain on as if the control is in normal mode. Outputs of the control, excluding LED and alarm relay, will NOT be affected by UPS. The UPS condition cannot occur during a compressor off cycle. During UPS warning, the alarm relay will cycle on and off. The cycle rate will be “on” for 5 seconds, “off” for 25 seconds, “on” for 5 seconds, “off” for 25 seconds, etc.

UPS warning code = 8

Swapped LT1/LT2 thermistors: During test mode, the control monitors to see if the LT1 and LT2 thermistors are in the appropriate places. If the control is in test mode, the control will lockout with code 9 after 30 seconds if:

- a. The compressor is on in the cooling mode and the LT1 sensor is colder than the LT2 sensor, or:
- b. The compressor is on in the heating mode and the LT2 sensor is colder than the LT1 sensor.

Swapped LT1/LT2 thermistor code = 9.

ESD (DXM2 only): The ESD (Emergency Shut Down) mode can be enabled from an external common signal to terminal ESD to shut down the unit. The green status light will flash code 3 when the unit is in ESD mode.

ESD mode = code 3 (green “status” LED)

Diagnostic Features

The LED on the CXM board advises the technician of the current status of the CXM control. The LED can display either the current CXM mode or the last fault in memory if in test mode. If there is no fault in memory, the LED will flash Code 1 (when in test mode).

The green status LED and red fault LED on the DXM2 board advise the technician of the current status of the DXM2 control. The status LED will indicate the current mode that the DXM2 control is in. The fault LED will ALWAYS flash a code representing the LAST fault in memory. If there is no fault in memory, the fault LED will flash Code 1. The yellow test LED will turn on when in test mode. **CAUTION: Do not restart units without inspection and remedy of faulting condition. Damage may occur.**

CXM/DXM2 Control Start-up Operation

The control will not operate until all inputs and safety controls are checked for normal conditions. The compressor will have a 5 minute anti-short cycle delay at power-up. The first time after power-up that there is a call for compressor, the compressor will follow a 5 to 80 second random start delay. After the random start delay and anti-short cycle delay, the compressor relay will be energized. On all subsequent compressor calls, the random start delay is omitted.

Unit Starting and Operating Conditions

Operating Limits

Environment – Units are designed for indoor installation only. Never install units in areas subject to freezing or where humidity levels could cause cabinet condensation (such as unconditioned spaces subject to 100% outside air).

Power Supply – A voltage variation of +/- 10% of nameplate utilization voltage is acceptable.

Determination of operating limits is dependent primarily upon three factors: 1) return air temperature. 2) water temperature, and 3) ambient temperature. When any one of these factors is at minimum or maximum levels, the other two factors should be at normal levels to ensure proper unit operation. Extreme variations in temperature and humidity and/or corrosive water or air will adversely affect unit performance, reliability, and service life. Consult Table 7 for operating limits.

Commissioning Conditions

Consult Table 8 for the particular model. Starting conditions vary depending upon model and are based upon the following notes:

Notes:

1. Conditions in Table 8 are not normal or continuous operating conditions. Minimum/maximum limits are start-up conditions to bring the building space up to occupancy temperatures. Units are not designed to operate under these conditions on a regular basis.
2. Voltage utilization range complies with AHRI Standard 110.

Table 7: Operating Limits

Operating Limits	HB	
	Cooling	Heating
Air Limits		
Min. ambient air, DB	45°F [7°C]	39°F [4°C]
Rated ambient air, DB	80.6°F [27°C]	68°F [20°C]
Max. ambient air, DB	130°F [54.4°C]	85°F [29°C]
Min. entering air, DB/WB	*65/50°F [18/10°C]	45°F [7.2°C]
Rated entering air, DB/WB	80.6/66.2°F [27/19°C]	68°F [20°C]
Max. entering air, DB/WB	95/75°F [35/24°C]	80°F [27°C]
Water Limits		
Min. entering water	30°F [-1°C]	20°F [-6.7°C]
Normal entering water	50-110°F [10-43°C]	30-70°F [-1 to 21°C]
Max. entering water	120°F [49°C]	90°F [32°C]
Normal Water Flow	1.5 to 3.0 gpm/ton [1.6 to 3.2 l/m per kW]	

*If with Condenser Hot Water Reheat 65/55°F (18/13°C)

Table 8: Starting Limits

Commissioning Limits	Cooling	Heating
Air Limits		
Min. ambient air, DB	45°F [7°C]	39°F [4°C]
Rated ambient air, DB	80.6°F [27°C]	68°F [20°C]
Max. ambient air, DB	130°F [54.4°C]	85°F [29°C]
Min. entering air, DB/WB	50/45°F [10/7°C]	40°F [4.5°C]
Rated entering air, DB/WB	80.6/66.2°F [27/19°C]	68°F [20°C]
Max. entering air, DB/WB	110/83°F [43/28°C]	80°F [27°C]
Water Limits		
Min. entering water	30°F [-1°C]	20°F [-6.7°C]
Normal entering water	50-110°F [10-43°C]	30-70°F [-1 to 21°C]
Max. entering water	120°F [49°C]	90°F [32°C]
Normal Water Flow	1.5 to 3.0 gpm/ton [1.6 to 3.2 l/m per kW]	

Piping System Cleaning and Flushing

Piping System Cleaning and Flushing

Cleaning and flushing the WLHP piping system is the single most important step to ensure proper start-up and continued efficient operation of the system.

Follow the instructions below to properly clean and flush the system:

1. Ensure that electrical power to the unit is disconnected.
2. Install the system with the supply hose connected directly to the return riser valve. Use a single length of flexible hose.
3. Fill the system with water. DO NOT allow system to overflow. Bleed all air from the system. Pressurize and check the system for leaks and repair as appropriate.
Models with Waterside Economizer also manually open economizer valve and coil air vents (2) to bleed air from coil.
4. Verify that all strainers are in place the manufacturer recommends a strainer with a #20 stainless steel wire mesh). Start the pumps, and systematically check each vent to ensure that all air is bled from the system.
5. Verify that make-up water is available. Adjust make-up water as required to replace the air which was bled from the system. Check and adjust the water/air level in the expansion tank.
6. Set the boiler to raise the loop temperature to approximately 86°F [30°C]. Open a drain at the lowest point in the system. Adjust the make-up water replacement rate to equal the rate of bleed.
7. Refill the system and add trisodium phosphate in a proportion of approximately 150 gallons [1/2 kg per 750 l] of water (or other equivalent approved cleaning agent). Reset the boiler to raise the loop temperature to 100°F [38°C]. Circulate the solution for a minimum of 8 to 24 hours. At the end of this period, shut off the circulating pump and drain the solution. Repeat system cleaning if desired.
8. When the cleaning process is complete, remove the short-circuited hoses. Reconnect the hoses to the proper supply, and return the connections to each of the units. Refill the system and bleed off all air.

9. Test the system pH with litmus paper. The system water should be in the range of pH 6.0 - 8.5 (see table 3). Add chemicals, as appropriate to maintain neutral pH levels.
10. When the system is successfully cleaned, flushed, refilled and bled, check the main system panels, safety cutouts and alarms. Set the controls to properly maintain loop temperatures.



CAUTION! DO NOT use “Stop Leak” or similar chemical agent in this system. Addition of chemicals of this type to the loop water will foul the heat exchanger and inhibit unit operation.

Note: The manufacturer strongly recommends all piping connections, both internal and external to the unit, be pressure tested by an appropriate method prior to any finishing of the interior space or before access to all connections is limited. Test pressure may not exceed the maximum allowable pressure for the unit and all components within the water system. The manufacturer will not be responsible or liable for damages from water leaks due to inadequate or lack of a pressurized leak test, or damages caused by exceeding the maximum pressure rating during installation.

HB with Waterside Economizer Option

Figure 23:

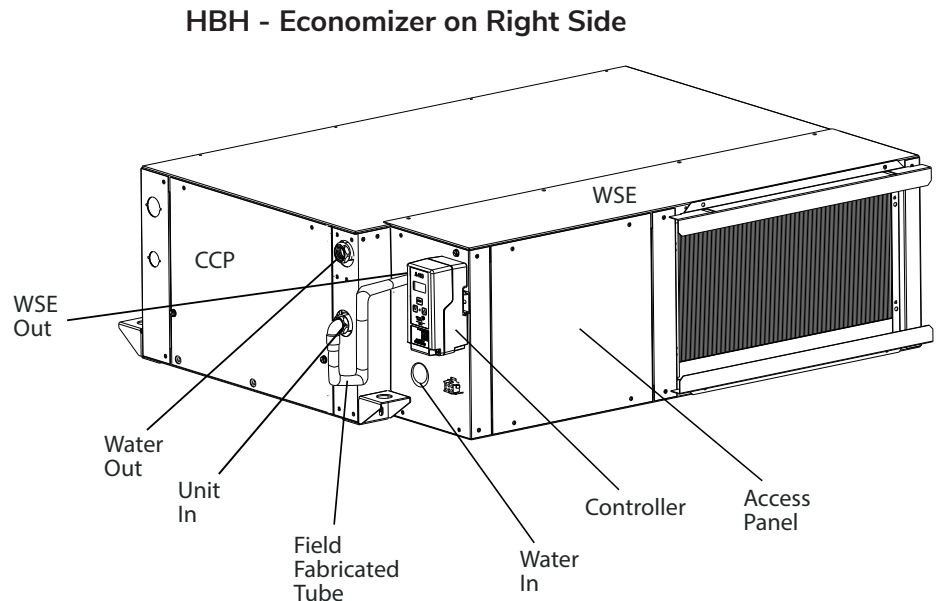
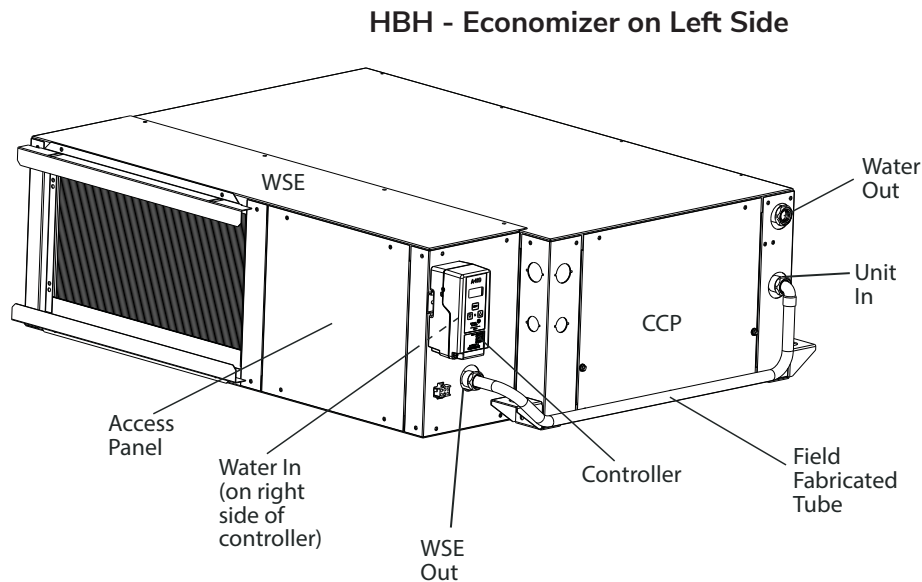

Notes:

1. Field to fabricate tube and connect from WSE - OUT to Unit - IN. Do not block compressor/control box service panel (CCP). Hoses are not recommended.
2. Access panel for access to 3 way valve and air bleed vents (2) at top of WSE coil headers. For vertical units and 1 at the top and 1 at the bottom for horizontal units.
3. All units require two external drain traps. The two drains may be connected after the vents.
4. Controllers are shipped inside, remove, slide on DIN rail, and connect molex.

HB with Waterside Economizer Option, Cont'd.

HBV - Economizer on Left Side

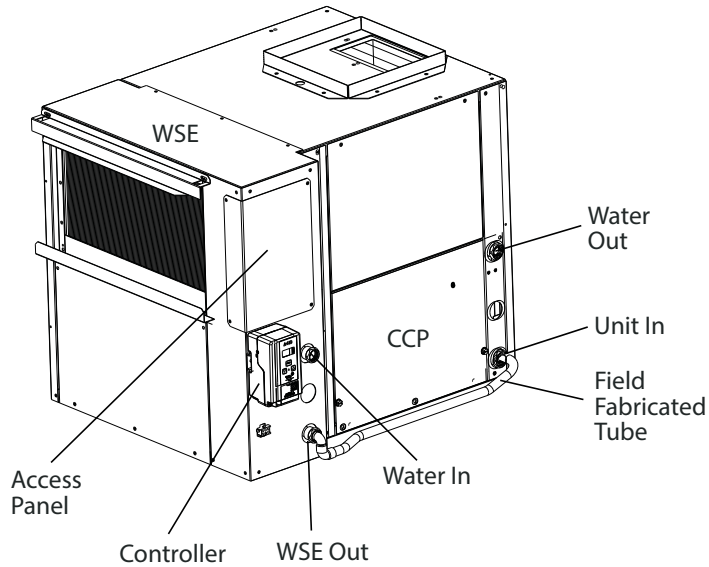

HBV - Economizer on Right Side

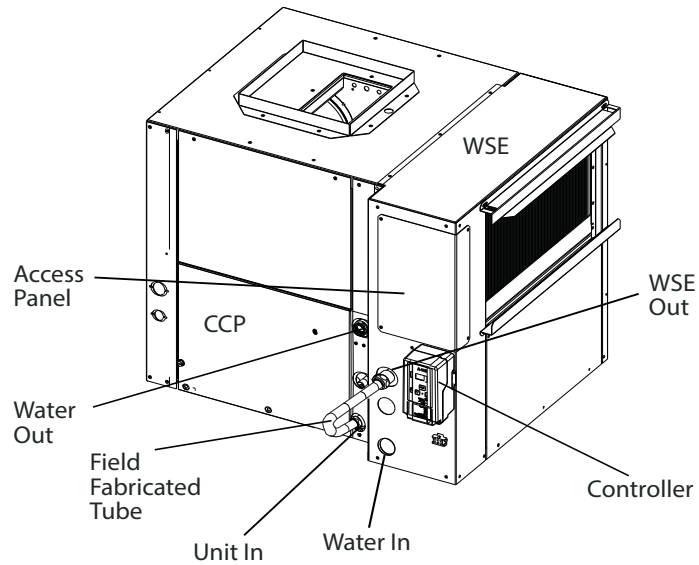

Notes:

1. Field to fabricate tube and connect from WSE - OUT to Unit - IN. Do not block compressor/control box service panel (CCP). Hoses are not recommended.
2. Access panel for access to 3 way valve and air bleed vents (2) at top of WSE coil headers. For vertical units and 1 at the top and 1 at the bottom for horizontal units.
3. All units require two external drain traps. The two drains may be connected after the vents.
4. Controllers are shipped inside, remove, slide on DIN rail, and connect molex.

Unit and System Checkout

WARNING!

WARNING! Polyolester Oil, commonly known as POE oil, is a synthetic oil used in many refrigeration systems including those with HFC-410A refrigerant. POE oil, if it ever comes in contact with PVC or CPVC piping, may cause failure of the PVC/CPVC. PVC/CPVC piping should never be used as supply or return water piping with water source heat pump products containing HFC-410A as system failures and property damage may result.

Unit and System Checkout

BEFORE POWERING SYSTEM, please check the following:

UNIT CHECKOUT

- ❑ Balancing/shutoff valves: Ensure that all isolation valves are open and water control valves are wired.
- ❑ Line voltage and wiring: Verify that voltage is within an acceptable range for the unit and wiring and fuses/breakers are properly sized. Verify that low voltage wiring is complete.
- ❑ Unit control transformer: Ensure that transformer has the properly selected voltage tap.
- ❑ Entering water and air: Ensure that entering water and air temperatures are within operating limits of Table 8a-b.
- ❑ Low water temperature cutout: Verify that low water temperature cut-out on the CXM/DXM2 control is properly set.
- ❑ Unit fan: Manually rotate fan to verify free rotation and ensure that blower wheel is secured to the motor shaft. Be sure to remove any shipping supports if needed. DO NOT oil motors upon start-up. Fan motors are pre-oiled at the factory. Check unit fan speed selection and compare to design requirements.
- ❑ Condensate line: Verify that condensate line is open and properly pitched toward drain.
- ❑ Water flow balancing: Record inlet and outlet water temperatures for each heat pump upon startup. This check can eliminate nuisance trip outs and high velocity water flow that could erode heat exchangers.
- ❑ Unit air coil and filters: Ensure that filter is clean and accessible. Clean air coil of all manufacturing oils.
- ❑ Unit controls: Verify that CXM or DXM2 field selection options are properly set.

SYSTEM CHECKOUT

- ❑ System water temperature: Check water temperature for proper range and also verify heating and cooling set points for proper operation.
- ❑ System pH: Check and adjust water pH if necessary to maintain a level between 6 and 8.5. Proper pH promotes longevity of hoses and fittings (see table 3).
- ❑ System flushing: Verify that all hoses are connected end to end when flushing to ensure that debris bypasses the unit heat exchanger, water valves and other components. Water used in the system must be potable quality initially and clean of dirt, piping slag, and strong chemical cleaning agents. Verify that all air is purged from the system. Air in the system can cause poor operation or system corrosion.
- ❑ Cooling tower/boiler: Check equipment for proper setpoints and operation.
- ❑ Standby pumps: Verify that the standby pump is properly installed and in operating condition.
- ❑ System controls: Verify that system controls function and operate in the proper sequence.
- ❑ Low water temperature cutout: Verify that low water temperature cut-out controls are provided for the outdoor portion of the loop. Otherwise, operating problems may occur.
- ❑ System control center: Verify that the control center and alarm panel have appropriate setpoints and are operating as designed.
- ❑ Miscellaneous: Note any questionable aspects of the installation.

CAUTION!

CAUTION! Verify that ALL water control valves are open and allow water flow prior to engaging the compressor. Freezing of the coax or water lines can permanently damage the heat pump.

CAUTION!

CAUTION! To avoid equipment damage, DO NOT leave system filled in a building without heat during the winter unless antifreeze is added to the water loop. Heat exchangers never fully drain by themselves and will freeze unless winterized with antifreeze.

Unit Start-Up Procedure

Unit Start-up Procedure

1. Turn the thermostat fan position to "ON". Blower should start.
2. Balance air flow at registers.
3. Adjust all valves to their full open positions. Turn on the line power to all heat pumps.
4. Room temperature should be within the minimum-maximum ranges of table 7. During start-up checks, loop water temperature entering the heat pump should be between 60°F [16°C] and 95°F [35°C].
5. Two factors determine the operating limits of water source heat pumps, (a) return air temperature, and (b) water temperature. When any one of these factors is at a minimum or maximum level, the other factor must be at normal level to ensure proper unit operation.
 - a. Adjust the unit thermostat to the warmest setting. Place the thermostat mode switch in the "COOL" position. Slowly reduce thermostat setting until the compressor activates.
 - b. Check for cool air delivery at the unit grille within a few minutes after the unit has begun to operate.

Note: Units have a five minute time delay in the control circuit that can be eliminated on the CXM/DXM2 control board as shown in Figure 23. See controls description for details.
 - c. Verify that the compressor is on and that the water flow rate is correct by measuring pressure drop through the heat exchanger using the P/T plugs and comparing to table 9.
 - d. Check the elevation and cleanliness of the condensate lines. Dripping may be a sign of a blocked line. Check that the condensate trap is filled to provide a water seal.
 - e. Refer to table 11. Check the temperature of both entering and leaving water. If temperature is within range, proceed with the test. Verify correct water flow by comparing unit pressure drop across the heat exchanger versus the data in table 9. Heat of rejection (HR) can be calculated and compared to submittal data capacity pages. The formula for HR for systems with water is as follows:
 $HR \text{ (Btuh)} = TD \times GPM \times 500$, where TD is the temperature difference between the entering and leaving water, and GPM is the flow rate in U.S. GPM, determined by comparing the pressure drop across the heat exchanger to table 9. In S-I units, the formula is as follows: $HR \text{ (kW)} = TD \times l/s \times 4.18$.
 - f. Check air temperature drop across the air coil when compressor is operating. Air temperature drop should be between 15°F and 25°F [8°C and 14°C].
 - g. Turn thermostat to "OFF" position. A hissing noise indicates proper functioning of the reversing valve.
6. Allow five (5) minutes between tests for pressure to equalize before beginning heating test.
 - a. Adjust the thermostat to the lowest setting. Place the thermostat mode switch in the "HEAT" position.
 - b. Slowly raise the thermostat to a higher temperature until the compressor activates.
 - c. Check for warm air delivery within a few minutes after the unit has begun to operate.
 - d. Refer to table 11. Check the temperature of both entering and leaving water. If temperature is within range, proceed with the test. If temperature is outside of the operating range, check refrigerant pressures and compare to table 10. Verify correct water flow by comparing unit pressure drop across the heat exchanger versus the data in table 9. Heat of extraction (HE) can be calculated and compared to submittal data capacity pages. The formula for HE for systems with water is as follows:
 $HE \text{ (kW)} = TD \times GPM \times 500$, where TD is the temperature difference between the entering and leaving water, and l/s is the flow rate in U.S. GPM, determined by comparing the pressure drop across the heat exchanger to tables 10a through 10e. In S-I units, the formula is as follows: $HE \text{ (kW)} = TD \times l/s \times 4.18$.
 - e. Check air temperature rise across the air coil when compressor is operating. Air temperature rise should be between 20°F and 30°F [11°C and 17°C].
 - f. Check for vibration, noise, and water leaks.
7. If unit fails to operate, perform troubleshooting analysis (see troubleshooting section). If the check described fails to reveal the problem and the unit still does not operate, contact a trained service technician to ensure proper diagnosis and repair of the equipment.
8. When testing is complete, set system to maintain desired comfort level.

Note: If performance during any mode appears abnormal, refer to the CXM/DXM2 section or troubleshooting section of this manual. To obtain maximum performance, the air coil should be cleaned before start-up. A 10% solution of dishwasher detergent and water is recommended.

Unit Start-Up Procedure, Cont'd.

Figure 23: Test Mode Pins

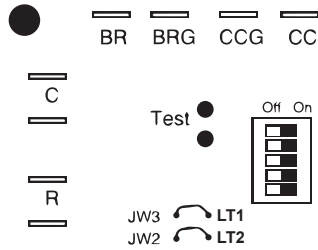

Short test pins together to enter Test Mode and speed-up timing and delays for 20 minutes.

! WARNING! !

WARNING! When the disconnect switch is closed, high voltage is present in some areas of the electrical panel. Exercise caution when working with energized equipment.

! CAUTION! !

CAUTION! Verify that ALL water control valves are open and allow water flow prior to engaging the compressor. Freezing of the coax or water lines can permanently damage the heat pump.

! CAUTION! !

CAUTION! Many units are installed with a factory or field supplied manual or electric shut-off valve. **DAMAGE WILL OCCUR** if shut-off valve is closed during unit operation. A high pressure switch must be installed on the heat pump side of any field provided shut-off valves and connected to the heat pump controls in series with the built-in refrigerant circuit high pressure switch to disable compressor operation if water pressure exceeds pressure switch setting. The field installed high pressure switch shall have a cut-out pressure of 300 psig and a cut-in pressure of 250 psig.

Unit Operating Conditions

Table 9: HB Coax Water Pressure Drop

Model	U.S. GPM	l/s	Pressure Drop, psi [kPa]*			
			30°F [-1°C]	50°F [10°C]	70°F [21°C]	90°F [32°C]
006	0.75	0.05	0.5 [3.7]	0.3 [2.3]	0.2 [1.6]	0.2 [1.6]
	1.1	0.07	0.8 [5.3]	0.5 [3.5]	0.4 [2.7]	0.3 [2.2]
	1.5	0.09	1.3 [8.8]	0.9 [6.1]	0.7 [4.8]	0.6 [4.0]
009	1.1	0.07	1.3 [9.0]	0.6 [4.4]	0.4 [2.8]	0.3 [1.9]
	1.8	0.11	2.1 [14.1]	1.4 [9.4]	1.1 [7.4]	0.9 [6.2]
	2.3	0.14	3.5 [24.3]	2.6 [17.9]	2.1 [14.7]	1.8 [12.7]
012	1.5	0.09	1.9 [12.8]	1.1 [7.6]	0.8 [5.3]	0.6 [4.1]
	2.3	0.15	3.6 [25.0]	2.6 [17.8]	2.1 [14.3]	1.8 [12.1]
	3.0	0.19	6.7 [46.1]	5.0 [34.3]	4.1 [28.3]	3.6 [24.5]
015	1.9	0.12	1.0 [6.9]	0.6 [4.4]	0.5 [3.4]	0.4 [2.8]
	2.8	0.18	1.8 [12.4]	1.4 [9.3]	1.1 [7.6]	1.0 [6.9]
	3.8	0.24	3.3 [22.7]	2.5 [17.5]	2.1 [14.7]	1.9 [13.1]
018	2.3	0.14	2.1 [14.5]	1.4 [9.9]	1.1 [7.6]	0.9 [6.2]
	3.4	0.21	3.4 [23.4]	2.6 [17.6]	2.1 [14.7]	1.8 [12.4]
	4.5	0.28	5.9 [40.6]	4.6 [31.5]	3.9 [26.9]	3.4 [23.4]
024	3.0	0.19	2.2 [15.2]	1.7 [11.6]	1.4 [9.6]	1.2 [8.3]
	4.5	0.28	4.0 [27.6]	3.2 [22.2]	2.8 [19.3]	2.5 [17.2]
	6.0	0.38	7.2 [49.6]	5.9 [40.6]	5.2 [35.8]	4.7 [32.4]
030	3.8	0.24	1.3 [9.0]	0.9 [6.1]	0.7 [4.8]	0.6 [4.1]
	5.6	0.35	2.3 [15.8]	1.8 [12.5]	1.5 [10.3]	1.4 [9.6]
	7.5	0.47	4.2 [28.9]	3.4 [23.2]	2.9 [20]	2.6 [17.9]
036	4.5	0.28	1.8 [12.4]	1.4 [9.6]	1.2 [8.3]	1.0 [6.9]
	6.8	0.43	3.1 [21.4]	2.4 [16.8]	2.1 [14.7]	1.9 [13.1]
	9.0	0.57	5.4 [37.2]	4.4 [30.0]	3.8 [26.2]	3.4 [23.4]
042	5.3	0.33	2.3 [15.8]	1.8 [12.1]	1.5 [10.3]	1.3 [9.0]
	7.9	0.50	4.3 [29.6]	3.5 [24.2]	3.1 [26.4]	2.8 [19.3]
	10.5	0.66	7.9 [54.4]	6.5 [44.8]	5.7 [39.3]	5.2 [35.8]
048	6.0	.038	1.8 [12.4]	1.5 [10.1]	1.3 [9.0]	1.2 [8.3]
	9.0	0.57	3.4 [23.4]	3.0 [20.4]	2.7 [18.6]	2.6 [17.9]
	12.0	0.76	6.2 [42.7]	5.5 [37.9]	5.1 [35.1]	4.8 [35.1]
060	7.5	0.47	3.4 [23.4]	2.8 [19.2]	2.4 [16.5]	2.2 [15.2]
	11.3	0.71	6.8 [46.9]	5.9 [40.8]	5.4 [37.2]	5.0 [34.5]
	15.0	0.95	12.6 [86.8]	11.1 [76.8]	10.3 [71.0]	9.6 [66.1]

Unit Operating Conditions, Cont'd.

Table 10: HB-Series Typical Unit Operating Pressures and Temperatures

006		COOLING						HEATING					
En-tering Water Temp °F	Water Flow GPM/ton	Suction Pressure PSIG	Dis-charge Pressure PSIG	Superheat °F	Subcooling °F	Water Temp Rise °F	Air Temp Drop °F DB	Suction Pressure PSIG	Dis-charge Pressure PSIG	Superheat °F	Subcooling °F	Water Temp Drop °F	Air Temp Rise °F DB
30*	1.5	124-134	159-179	17-22	5-10	18.7-20.7	17-23	71-81	295-315	13-18	5-10	5.9-7.9	17-23
	2.25	120-130	147-167	20-25	5-10	13.6-15.6	18-24	72-82	296-316	14-19	5-10	4.2-6.2	17-23
	3	117-127	136-156	24-29	5-10	8.5-10.5	18-24	74-84	297-317	15-20	5-10	2.5-4.5	17-23
50	1.5	132-142	210-230	7-12	5-10	16.2-18.2	18-24	105-115	330-350	8-13	9-14	8.2-10.2	22-28
	2.25	131-141	199-219	8-13	5-10	11.9-13.9	19-25	110-120	335-355	9-14	9-14	6.1-8.1	22-28
	3	130-140	189-209	9-14	4-9	7.7-9.7	19-25	115-125	339-359	9-14	9-14	4-6	23-29
70	1.5	136-146	275-295	5-10	5-10	15.1-17.1	17-23	136-146	362-382	9-14	10-15	11.3-13.3	27-33
	2.25	136-146	262-282	6-11	4-9	11.1-13.1	18-24	141-151	368-388	9-14	10-15	16.9-18.9	28-34
	3	135-145	250-270	6-11	4-9	7.2-9.2	18-24	147-157	374-394	9-14	10-15	5.6-7.6	29-35
90	1.5	142-152	365-385	5-10	4-9	13.8-15.8	16-22	170-180	402-422	14-19	12-17	14.4-16.4	33-39
	2.25	141-151	353-373	5-10	4-9	10.2-12.2	16-22	173-183	407-427	15-20	12-17	11.1-13.1	33-39
	3	140-150	340-360	5-10	4-9	6.6-8.6	16-22	177-187	412-432	17-22	12-17	7.7-9.1	34-40
110	1.5	148-158	462-482	5-10	4-9	12.5-14.5	14-20						
	2.25	147-157	449-469	5-10	3-8	9.2-11.2	14-20						
	3	146-156	438-458	5-10	3-8	5.9-7.9	14-20						

*Based on 15% Methanol antifreeze solution

009		COOLING						HEATING					
En-tering Water Temp °F	Water Flow GPM/ton	Suction Pressure PSIG	Discharge Pressure PSIG	Superheat °F	Subcooling °F	Water Temp Rise °F	Air Temp Drop °F DB	Suction Pressure PSIG	Dis-charge Pressure PSIG	Superheat °F	Subcooling °F	Water Temp Drop °F	Air Temp Rise °F DB
30*	1.5	113-123	160-180	22-27	13-18	19.5-21.5	17-23	69-79	331-351	11-16	20-25	7.3-9.3	17-23
	2.25	110-120	147-167	25-30	11-16	14.2-16.2	17-23	72-82	335-355	11-16	20-25	5.4-7.4	18-24
	3	108-118	135-155	28-33	9-14	8.9-10.9	16-21	75-85	339-359	11-16	21-26	3.5-5.5	19-25
50	1.5	124-134	211-231	9-14	10-15	18-20	17-23	101-111	360-380	9-14	20-25	9.8-11.8	23-29
	2.25	122-132	199-219	12-17	9-14	13.2-15.2	17-23	105-115	363-383	9-14	19-24	7.4-9.4	24-30
	3	120-130	187-207	15-20	8-13	8.4-10.4	17-23	110-120	366-386	9-14	19-24	4.9-6.9	24-30
70	1.5	129-139	275-295	7-12	8-13	17.4-19.4	16-22	130-140	400-420	10-15	20-25	12.8-14.8	28-34
	2.25	128-138	261-281	8-13	7-12	12.8-14.8	16-22	137-147	407-427	10-15	19-24	9.6-11.6	29-35
	3	127-137	247-267	8-13	6-11	8.2-10.2	16-22	144-154	414-434	10-15	18-23	6.4-8.4	30-36
90	1.5	136-146	364-384	7-12	3-8	15.7-17.7	15-21	170-180	449-469	13-18	17-22	16-18	34-40
	2.25	135-145	350-370	7-12	4-9	11.7-13.7	15-21	178-188	455-475	14-19	15-20	12-14	35-41
	3	134-144	336-356	7-12	4-9	7.6-9.6	15-21	186-196	460-480	15-20	13-18	7.9-9.9	36-42
110	1.5	142-152	467-487	5-10	4-9	13.5-15.5	13-19						
	2.25	141-151	451-471	5-10	4-9	9.9-11.9	13-19						
	3	140-150	435-455	5-10	3-8	6.3-8.3	13-19						

*Based on 15% Methanol antifreeze solution

012		COOLING						HEATING					
En-tering Water Temp °F	Water Flow GPM/ton	Suction Pressure PSIG	Discharge Pressure PSIG	Superheat °F	Subcooling °F	Water Temp Rise °F	Air Temp Drop °F DB	Suction Pressure PSIG	Dis-charge Pressure PSIG	Superheat °F	Subcooling °F	Water Temp Drop °F	Air Temp Rise °F DB
30*	1.5	116-126	155-175	14-19	9-14	19.4-21.4	18-24	70-80	311-331	8-13	8-13	6.9-8.9	18-24
	2.25	113-123	144-164	15-20	8-13	14.3-16.3	18-24	72-82	315-335	8-13	8-13	5.1-7.1	19-25
	3	111-121	132-152	17-22	6-11	9.1-11.1	18-24	75-85	319-339	8-13	8-13	3.2-5.2	19-25
50	1.5	123-133	208-228	8-13	9-14	18.1-20.1	17-23	102-112	354-364	8-13	9-14	9.3-11.3	25-31
	2.25	122-132	196-216	9-14	7-12	13.4-15.4	18-24	106-116	355-375	8-13	9-14	7-9	26-32
	3	121-131	184-204	9-14	5-10	8.6-10.6	18-24	110-120	355-375	8-13	9-14	4.6-6.6	26-32
70	1.5	127-137	266-286	7-12	8-13	17.2-19.2	16-22	131-141	392-412	9-14	8-13	12-14	30-36
	2.25	126-136	255-275	8-13	7-12	12.7-14.7	16-22	137-147	395-415	9-14	8-13	9-11	31-37
	3	126-136	244-264	8-13	5-10	8.2-10.2	16-22	144-154	398-418	9-14	7-12	6-8	32-38
90	1.5	133-143	362-382	6-11	7-12	16-18	15-21	175-185	443-463	10-15	3-8	15-17	36-42
	2.25	132-142	342-362	7-12	5-10	11.8-13.8	15-21	183-193	452-472	11-16	3-8	11.2-13.2	37-43
	3	132-142	331-351	7-12	4-9	7.6-9.6	15-21	190-200	461-491	13-18	3-8	7.4-9.4	38-44
110	1.5	140-150	459-479	6-11	4-9	14.4-16.4	13-19						
	2.25	140-150	441-461	6-11	4-9	10.6-12.6	13-19						
	3	139-149	431-451	6-11	3-8	6.9-8.9	13-19						

*Based on 15% Methanol antifreeze solution

Unit Operating Conditions, Cont'd.

Table 10: HB-Series Typical Unit Operating Pressures and Temperatures: Continued

015		COOLING						HEATING					
En-tering Water Temp °F	Water Flow GPM/ton	Suction Pressure PSIG	Dis-charge Pressure PSIG	Superheat °F	Subcooling °F	Water Temp Rise °F	Air Temp Drop °F DB	Suction Pressure PSIG	Dis-charge Pressure PSIG	Superheat °F	Subcooling °F	Water Temp Drop °F	Air Temp Rise °F DB
30*	1.5	116-126	167-187	15-20	9-14	18.3-20.3	18-24	70-80	279-299	6-11	1-5	7-8	16-22
	2.25	116-126	154-174	15-20	7-12	13.9-15.9	19-25	73-83	281-301	7-12	1-5	5.1-7.1	17-23
	3	116-126	140-160	15-20	7-12	9.5-11.5	19-25	75-85	284-304	7-12	1-5	3.3-5.3	17-23
50	1.5	128-138	194-214	11-14	9-14	17.9-19.9	18-24	102-112	312-332	10-15	2-6	9.9-11.9	22-28
	2.25	128-138	180-200	11-14	7-12	13.7-15.7	19-25	106-116	316-336	10-15	2-6	7.4-9.4	23-29
	3	128-138	166-186	11-14	7-12	9.4-11.4	19-25	110-120	321-341	10-15	2-6	4.9-6.9	23-29
70	1.5	136-146	289-309	7-12	9-14	17.4-19.4	17-23	128-138	335-355	12-17	3-8	12.9-14.9	27-34
	2.25	136-146	275-295	7-12	7-12	15.3-17.3	18-24	134-144	340-360	12-17	3-8	9.7-11.7	28-35
	3	136-146	261-281	7-12	6-11	8.8-10.8	18-24	141-151	346-366	12-17	3-8	6.5-8.5	28-35
90	1.5	139-149	386-406	6-11	9-14	16.8-18.8	16-22	160-170	373-393	15-20	3-8	15.8-17.8	30-38
	2.25	139-149	370-390	6-11	7-12	12.5-14.5	16-22	167-177	380-400	16-21	3-8	12-14	31-39
	3	139-149	356-376	6-11	6-11	8.2-9.2	16-22	174-184	388-408	17-22	3-8	8.1-10.1	32-40
110	1.5	145-155	483-503	6-11	9-14	15.8-17.8	15-21						
	2.25	144-154	466-486	6-11	7-12	11.7-13.7	15-21						
	3	143-153	449-469	6-11	6-11	7.5-9.5	15-21						

*Based on 15% Methanol antifreeze solution

018		COOLING						HEATING					
En-tering Water Temp °F	Water Flow GPM/ton	Suction Pressure PSIG	Dis-charge Pressure PSIG	Superheat °F	Subcooling °F	Water Temp Rise °F	Air Temp Drop °F DB	Suction Pressure PSIG	Dis-charge Pressure PSIG	Superheat °F	Subcooling °F	Water Temp Drop °F	Air Temp Rise °F DB
30*	1.5	122-132	171-191	15-20	14-19	22.5-24.5	20-28	70-80	272-292	4-9	2-6	7.4-9.4	18-24
	2.25	122-132	157-177	15-20	13-18	16.8-19.8	20-28	73-83	275-295	4-9	2-6	5.5-7.5	19-25
	3	122-132	145-165	15-20	13-18	11.2-13.2	20-28	77-87	278-298	4-9	2-6	3.5-5.5	19-25
50	1.5	136-146	198-218	10-15	14-19	22-24	19-25	101-111	302-322	8-13	3-7	10.3-12.3	23-29
	2.25	134-144	183-203	10-15	13-18	16.5-18.5	19-25	105-115	306-326	8-13	3-7	7.9-9.9	24-30
	3	133-143	171-191	11-16	13-18	11-13	19-25	109-119	311-331	8-13	3-7	5.5-7.5	25-31
70	1.5	139-149	293-313	6-10	14-19	19-21	18-24	130-140	329-349	10-15	4-9	13.6-15.6	27-33
	2.25	138-148	280-300	6-10	13-18	14.4-16.4	18-24	137-147	337-357	10-15	4-9	10.4-12.4	29-35
	3	137-147	267-287	7-11	13-18	9.8-11.7	18-24	139-149	342-362	10-15	4-9	7.2-9.2	30-36
90	1.5	142-152	389-409	5-10	17-22	16-18	17-23	160-170	360-380	13-18	5-10	17-19	33-41
	2.25	141-151	376-396	5-10	15-20	12.3-14.3	17-23	169-179	368-388	14-19	5-10	12.9-14.9	35-43
	3	140-150	363-383	5-10	13-18	8.5-10.5	17-23	178-188	376-396	14-19	4-9	8.8-10.8	36-44
110	1.5	148-158	486-506	5-10	17-22	14.9-16.9	16-22						
	2.25	147-157	472-492	5-10	15-20	11.4-13.4	16-22						
	3	146-156	458-478	5-10	13-18	7.8-9.8	16-22						

*Based on 15% Methanol antifreeze solution

024		COOLING						HEATING					
En-tering Water Temp °F	Water Flow GPM/ton	Suction Pressure PSIG	Dis-charge Pressure PSIG	Superheat °F	Subcooling °F	Water Temp Rise °F	Air Temp Drop °F DB	Suction Pressure PSIG	Dis-charge Pressure PSIG	Superheat °F	Subcooling °F	Water Temp Drop °F	Air Temp Rise °F DB
30*	1.5	121-131	174-194	13-18	6-11	19.3-21.3	20-28	65-75	287-307	4-9	3-8	6.8-8.8	17-23
	2.25	120-130	165-185	13-18	5-10	14.5-16.5	20-28	68-78	290-310	5-10	3-8	5-7	18-24
	3	120-130	155-175	13-18	5-10	9.6-11.6	20-28	71-81	292-312	5-10	3-8	3.2-5.2	18-24
50	1.5	127-137	245-265	8-13	6-11	18.3-20.3	19-27	96-106	318-338	6-11	3-8	9.8-11.8	22-28
	2.25	128-138	231-251	8-13	7-12	13.7-15.7	19-27	101-111	322-342	7-12	3-8	7.2-9.2	23-29
	3	128-138	217-237	8-13	7-12	9.1-11.1	19-27	105-115	327-347	8-13	3-8	4.8-6.8	24-30
70	1.5	130-140	352-372	6-11	8-13	17.5-19.5	18-26	127-137	349-369	9-14	3-8	12.7-14.7	27-34
	2.25	130-140	334-354	6-11	9-14	26.2-28.2	18-26	132-142	353-373	9-14	3-8	9.5-11.5	28-35
	3	130-140	306-326	6-11	9-14	8.7-10.7	18-26	137-147	358-378	10-15	3-8	6.3-8.3	29-36
90	1.5	134-144	439-459	5-10	11-16	16.7-18.7	17-23	159-169	379-399	13-18	3-8	15.6-17.6	32-40
	2.25	133-143	416-436	5-10	12-17	12.5-14.5	17-23	164-174	384-404	14-19	3-8	11.7-13.7	33-41
	3	133-143	394-414	5-10	12-17	8.3-10.3	17-23	170-180	390-410	16-21	3-8	7.8-9.8	34-42
110	1.5	140-150	536-556	4-9	22-27	17.1-19.1	17-23						
	2.25	139-149	512-532	4-9	19-23	12.6-14.6	17-23						
	3	138-148	488-508	4-9	17-22	8-10	17-23						

*Based on 15% Methanol antifreeze solution

Unit Operating Conditions, Cont'd.

Table 10: HB-Series Typical Unit Operating Pressures and Temperatures: Continued

030		COOLING						HEATING					
Entering Water Temp °F	Water Flow GPM/ton	Suction Pressure PSIG	Dis-charge Pressure PSIG	Superheat °F	Subcooling °F	Water Temp Rise °F	Air Temp Drop °F DB	Suction Pressure PSIG	Dis-charge Pressure PSIG	Superheat °F	Subcooling °F	Water Temp Drop °F	Air Temp Rise °F DB
30*	1.5	113-123	188-208	14-19	14-19	19.5-21.5	18-26	67-77	322-342	8-13	15-20	6.9-8.9	17-25
	2.25	114-124	177-197	14-19	13-18	14.5-16.5	19-27	69-79	324-344	8-13	15-20	5.1-7.1	18-26
	3	114-124	166-186	14-19	13-18	9.5-11.5	19-27	71-81	326-346	8-13	15-20	3.3-5.3	18-26
50	1.5	124-134	248-268	11-16	14-19	18.7-20.7	18-26	95-105	346-366	10-15	15-20	9.8-11.8	23-31
	2.25	124-134	233-253	11-16	13-18	13.9-15.9	19-27	99-109	350-370	10-15	15-20	7.3-9.3	24-32
	3	124-134	218-238	11-16	13-18	9.1-11.1	19-27	103-113	355-375	11-16	15-20	4.8-6.8	25-33
70	1.5	132-142	333-353	9-14	13-18	17.5-19.5	18-26	125-135	376-396	13-18	14-19	12.7-14.7	27-35
	2.25	132-142	313-333	9-14	12-17	13-15	18-26	133-143	386-406	13-18	14-19	9.8-11.8	28-36
	3	132-142	293-313	9-14	12-17	8.5-10.5	18-26	136-146	393-413	13-18	14-19	6.4-8.4	30-38
90	1.5	135-145	431-451	7-12	17-22	16.5-18.5	17-25	155-165	415-435	15-20	13-18	15.6-18.6	33-41
	2.25	135-145	411-431	7-12	15-20	12.3-14.3	17-25	167-177	422-442	16-21	13-18	11.8-13.8	34-42
	3	135-145	391-411	7-12	13-18	8-10	17-25	170-180	430-450	17-22	13-18	7.9-9.9	36-44
110	1.5	140-150	528-548	6-11	17-22	16.2-18.2	16-24						
	2.25	140-150	506-526	7-12	15-20	11.9-13.9	16-24						
	3	139-149	485-505	7-12	13-18	7.6-9.6	16-24						

*Based on 15% Methanol antifreeze solution

036		COOLING						HEATING					
Entering Water Temp °F	Water Flow GPM/ton	Suction Pressure PSIG	Dis-charge Pressure PSIG	Superheat °F	Subcooling °F	Water Temp Rise °F	Air Temp Drop °F DB	Suction Pressure PSIG	Dis-charge Pressure PSIG	Superheat °F	Subcooling °F	Water Temp Drop °F	Air Temp Rise °F DB
30*	1.5	113-123	185-205	17-22	9-14	19.5-21.5	18-26	64-74	327-347	4-9	15-20	7.7-9.7	19-27
	2.25	113-123	174-194	17-22	8-13	14.5-16.5	19-27	66-76	331-351	4-9	15-20	5.7-7.7	19-27
	3	113-123	163-183	17-22	8-13	9.6-11.6	19-27	69-79	335-355	4-9	15-20	3.7-5.7	20-28
50	1.5	121-131	249-269	12-17	9-14	19.4-21.4	17-25	91-101	360-380	10-15	15-20	11.2-13.2	25-33
	2.25	120-130	231-251	12-17	8-13	14.4-16.4	18-26	96-106	370-390	9-14	16-21	8.2-10.2	26-34
	3	120-130	214-234	12-17	8-13	9.4-11.4	18-26	102-112	380-400	8-13	16-21	5.2-7.2	27-35
70	1.5	128-138	327-347	9-14	13-18	19.1-21.1	16-24	125-135	402-422	10-15	14-19	14.7-16.7	32-40
	2.25	128-138	304-324	9-14	11-16	14.1-16.1	17-25	132-142	413-433	10-15	14-19	11-13	33-41
	3	127-137	282-302	9-14	10-15	9.1-11.1	17-25	140-150	423-443	10-15	14-19	7.3-9.3	34-42
90	1.5	132-142	416-436	8-13	20-25	18.8-20.8	15-23	158-168	445-465	13-18	12-17	18.1-20.1	37-45
	2.25	132-142	396-416	8-13	18-23	13.9-15.9	16-24	167-177	456-476	13-18	11-16	13.8-15.8	38-46
	3	131-141	376-396	8-13	16-21	8.9-10.9	16-24	177-187	467-487	14-19	11-16	9.4-11.4	40-48
110	1.5	138-148	550-570	8-13	20-25	18.5-20.5	15-23						
	2.25	136-146	525-545	8-13	18-23	13.6-15.6	15-23						
	3	135-145	500-520	8-13	16-21	8.7-10.7	15-23						

*Based on 15% Methanol antifreeze solution

042		COOLING						HEATING					
Entering Water Temp °F	Water Flow GPM/ton	Suction Pressure PSIG	Dis-charge Pressure PSIG	Superheat	Subcooling	Water Temp Rise °F	Air Temp Drop °F DB	Suction Pressure PSIG	Dis-charge Pressure PSIG	Superheat	Subcooling	Water Temp Drop °F	Air Temp Rise °F DB
30*	1.5	115-125	174-194	12-17	10-15	19.8-21.8	16-24	66-76	314-334	6-11	11-16	7.3-9.3	18-26
	2.25	115-125	159-179	12-17	9-14	14.6-16.6	16-24	69-79	318-338	5-10	12-17	5.4-7.4	19-27
	3	115-125	144-164	12-17	9-14	9.5-11.5	16-24	72-82	321-341	4-9	12-17	3.4-5.4	19-27
50	1.5	123-133	233-253	9-14	10-15	19-21	16-24	97-107	354-374	9-14	13-18	10.2-12.2	24-32
	2.25	122-132	219-239	9-14	9-14	14-16	16-24	101-111	360-380	8-13	13-18	7.6-9.6	25-33
	3	122-132	205-225	9-14	9-14	9.1-11.1	16-24	106-116	365-385	6-11	13-18	5-7	26-34
70	1.5	128-138	309-329	6-11	12-17	18.3-20.3	16-24	130-140	394-414	7-12	13-18	13.3-15.3	30-38
	2.25	128-138	290-310	6-11	11-14	13.5-15.5	16-24	136-146	401-421	7-12	13-18	9.9-1.9	31-39
	3	128-138	271-291	6-11	11-14	8.7-10.7	16-24	143-153	409-429	8-13	13-18	6.6-8.6	32-40
90	1.5	133-143	406-426	5-10	14-19	17.6-19.6	16-24	164-174	434-454	10-15	12-17	16.4-18.4	37-45
	2.25	133-143	386-406	5-10	13-18	12.9-14.9	16-24	172-182	443-463	11-16	12-17	12.3-14.3	38-46
	3	132-142	367-387	5-10	13-18	8.3-10.3	16-24	180-190	453-473	11-16	12-17	8.3-10.3	39-47
110	1.5	138-148	505-525	5-10	19-24	16.8-18.8	16-24						
	2.25	138-148	484-504	5-10	16-21	12.4-14.4	16-24						
	3	138-148	463-483	5-10	14-19	7.9-9.9	16-24						

*Based on 15% Methanol antifreeze solution

Unit Operating Conditions, Cont'd.

Table 10: HB-Series Typical Unit Operating Pressures and Temperatures: Continued

048		COOLING						HEATING					
Entering Water Temp °F	Water Flow GPM/ton	Suction Pressure PSIG	Discharge Pressure PSIG	Superheat °F	Subcooling °F	Water Temp Rise °F	Air Temp Drop °F DB	Suction Pressure PSIG	Discharge Pressure PSIG	Superheat °F	Subcooling °F	Water Temp Drop °F	Air Temp Rise °F DB
30*	1.5	119-129	190-210	15-20	10-15	19.3-21.3	18-26	63-73	284-304	5-10	3-8	6.9-8.9	17-25
	2.25	119-129	179-199	15-20	9-14	14.6-16.6	19-27	66-76	288-308	6-10	3-8	5-7	18-26
	3	119-129	158-178	15-20	9-14	9.8-11.8	19-27	69-79	292-312	6-11	3-8	3.1-5.1	18-26
50	1.5	124-134	248-268	10-15	10-15	19-21	18-26	92-102	309-329	8-13	3-8	9.5-11.5	23-31
	2.25	123-133	230-250	10-15	9-14	14.3-16.3	19-27	96-106	313-333	9-14	3-8	7-9	24-32
	3	123-133	213-233	10-15	9-14	9.6-11.6	19-27	100-110	317-337	9-14	3-8	4.6-6.6	24-32
70	1.5	129-139	337-357	8-13	12-17	18.6-20.6	17-25	123-133	339-359	11-16	3-8	12.5-14.5	29-37
	2.25	129-139	328-348	8-13	11-16	14-16	18-26	128-138	344-364	11-16	3-8	9.3-11.3	29-37
	3	129-139	300-320	8-13	11-16	9.4-11.4	18-26	133-143	350-370	12-17	3-8	6.2-8.2	30-38
90	1.5	134-144	426-446	6-11	15-20	18.2-20.2	16-24	153-163	369-389	14-19	1-6	15.4-17.4	33-41
	2.25	134-144	406-426	6-11	15-20	13.7-15.7	17-25	160-170	376-396	15-20	1-6	11.6-13.6	35-43
	3	134-144	386-406	6-11	15-20	9.2-11.2	17-25	167-177	384-404	16-21	1-6	7.8-9.8	36-44
110	1.5	140-150	560-580	4-9	23-28	17.7-19.7	16-24						
	2.25	140-150	536-556	4-9	20-25	13.4-15.4	16-24						
	3	139-149	511-531	4-9	18-22	9-11	16-24						

*Based on 15% Methanol antifreeze solution

060		COOLING						HEATING					
Entering Water Temp °F	Water Flow GPM/ton	Suction Pressure PSIG	Discharge Pressure PSIG	Superheat °F	Subcooling °F	Water Temp Rise °F	Air Temp Drop °F DB	Suction Pressure PSIG	Discharge Pressure PSIG	Superheat °F	Subcooling °F	Water Temp Drop °F	Air Temp Rise °F DB
30*	1.5	108-118	180-200	16-21	10-15	20.6	19-27	61-71	314-334	6-11	14-19	7.6-9.6	19-27
	2.25	108-118	165-185	16-21	9-14	15.2-17.2	20-28	64-74	317-337	7-12	13-18	5.6-7.6	20-28
	3	108-118	150-170	16-21	9-14	9.7-11.7	20-28	66-76	319-339	7-12	13-18	3.6-5.6	20-28
50	1.5	113-123	206-226	11-14	10-15	19.8-21.8	18-26	90-100	350-370	11-16	14-19	10.5-12.5	25-33
	2.25	113-123	190-210	11-14	9-14	14.5-16.5	19-27	95-105	357-377	11-16	14-19	7.9-9.9	27-35
	3	113-123	173-193	11-14	9-14	9.3-11.3	19-27	99-109	364-384	10-15	14-19	5.2-7.2	28-36
70	1.5	119-129	305-325	9-14	12-17	18.8-20.8	17-25	123-133	391-411	12-17	14-19	13.7-15.7	33-41
	2.25	118-128	287-307	9-14	11-14	13.8-15.8	18-26	129-139	399-419	12-17	14-19	10.3-12.3	34-42
	3	118-128	269-289	9-14	11-14	8.8-10.8	18-26	135-145	407-427	13-18	14-19	6.9-8.9	35-43
90	1.5	124-134	402-422	7-12	14-19	17.8-19.8	16-24	157-167	431-451	13-18	13-18	16.8-18.8	38-46
	2.25	124-134	382-402	7-12	13-18	13.1-15.1	17-25	164-184	440-460	14-19	13-18	12.7-14.7	39-47
	3	123-133	363-383	7-12	13-18	8.3-10.3	17-25	172-182	450-470	16-21	12-17	8.6-10.6	41-49
110	1.5	130-140	500-520	7-12	20-25	17-19	16-24						
	2.25	129-139	479-499	6-11	16-21	12.4-14.4	16-24						
	3	128-138	458-478	5-10	13-18	7.8-9.8	16-24						

*Based on 15% Methanol antifreeze solution

Table 11: Water Temperature Change Through Heat Exchanger

Water Flow, gpm [l/m]	Rise, Cooling °F, [°C]	Drop, Heating °F, [°C]
For Closed Loop: Ground Source or Closed Loop Systems at 3 gpm per ton [3.2 l/m per kW]	9 - 12 [5 - 6.7]	4 - 8 [2.2 - 4.4]
For Open Loop: Ground Water Systems at 1.5 gpm per ton [1.6 l/m per kW]	20 - 26 [11.1 - 14.4]	10 - 17 [5.6 - 9.4]

Preventive Maintenance

Water Coil Maintenance - (Direct ground water applications only) If the system is installed in an area with a known high mineral content (125 P.P.M. or greater) in the water, it is best to establish a periodic maintenance schedule with the owner so the coil can be checked regularly. Consult the well water applications section of this manual for a more detailed water coil material selection. Should periodic coil cleaning be necessary, use standard coil cleaning procedures, which are compatible with the heat exchanger material and copper water lines. Generally, the more water flowing through the unit, the less chance for scaling. Therefore, 1.5 gpm per ton [1.6 l/m per kW] is recommended as a minimum flow. Minimum flow rate for entering water temperatures below 50°F [10°C] is 2.0 gpm per ton [2.2 l/m per kW].

Water Coil Maintenance - (All other water loop applications) Generally water coil maintenance is not needed for closed loop systems. However, if the piping is known to have high dirt or debris content, it is best to establish a periodic maintenance schedule with the owner so the water coil can be checked regularly. Dirty installations are typically the result of deterioration of iron or galvanized piping or components in the system. Open cooling towers requiring heavy chemical treatment and mineral buildup through water use can also contribute to higher maintenance. Should periodic coil cleaning be necessary, use standard coil cleaning procedures, which are compatible with both the heat exchanger material and copper water lines. Generally, the more water flowing through the unit, the less chance for scaling. However, flow rates over 3 gpm per ton (3.9 l/m per kW) can produce water (or debris) velocities that can erode the heat exchanger wall and ultimately produce leaks.

Filters - Filters must be clean to obtain maximum performance. Filters should be inspected every month under normal operating conditions and be replaced when necessary. Units should never be operated without a filter.

Washable, high efficiency, electrostatic filters, when dirty, can exhibit a very high pressure drop for the fan motor and reduce air flow, resulting in poor performance. It is especially important to provide consistent washing of these filters (in the opposite direction of the normal air flow) once per month using a high pressure wash similar to those found at self-serve car washes.

Condensate Drain - In areas where airborne bacteria may produce a “slimy” substance in the drain pan, it may be necessary to treat the drain pan chemically with an algaecide approximately every three months to minimize the problem. The condensate pan may also need to be cleaned periodically to ensure indoor air quality. The condensate drain can pick up lint and dirt, especially with dirty filters. Inspect the drain twice a year to avoid the possibility of plugging and eventual overflow.

Compressor - Conduct annual amperage checks to ensure that amp draw is no more than 10% greater than indicated on the serial plate data.

Fan Motors - All units have lubricated fan motors. Fan motors should never be lubricated unless obvious, dry operation is suspected. Periodic maintenance oiling is not recommended, as it will result in dirt accumulating in the excess oil and cause eventual motor failure. Conduct annual dry operation check and amperage check to ensure amp draw is no more than 10% greater than indicated on serial plate data.

Air Coil - The air coil must be cleaned to obtain maximum performance. Check once a year under normal operating conditions and, if dirty, brush or vacuum clean. Care must be taken not to damage the aluminum fins while cleaning. CAUTION: Fin edges are sharp.

Cabinet - Do not allow water to stay in contact with the cabinet for long periods of time to prevent corrosion of the cabinet sheet metal. Generally, vertical cabinets are set up from the floor a few inches [7 - 8 cm] to prevent water from entering the cabinet. The cabinet can be cleaned using a mild detergent.

Refrigerant System - To maintain sealed circuit integrity, do not install service gauges unless unit operation appears abnormal. Reference the operating charts for pressures and temperatures. Verify that air and water flow rates are at proper levels before servicing the refrigerant circuit.

Functional Troubleshooting

Fault	Htg	Clg	Possible Cause	Solution			
Main power problems	X	X	Green Status LED Off	Check line voltage circuit breaker and disconnect.			
				Check for line voltage between L1 and L2 on the contactor.			
				Check for 24VAC between R and C on CXM/DXM2			
				Check primary/secondary voltage on transformer.			
HP Fault Code 2 High Pressure		X	Reduced or no water flow in cooling	Check pump operation or valve operation/setting. Check water flow adjust to proper flow rate.			
		X	Water Temperature out of range in cooling	Bring water temp within design parameters.			
	X		Reduced or no air flow in heating	Check for dirty air filter and clean or replace.			
				Check fan motor operation and airflow restrictions.			
				Dirty Air Coil- construction dust etc. Too high of external static. Check static vs blower table.			
	X		Air temperature out of range in heating	Bring return air temp within design parameters.			
	X	X	Overcharged with refrigerant	Check superheat/subcooling vs typical operating condition table.			
X	X	Bad HP Switch	Check switch continuity and operation. Replace.				
LP/LOC Fault Code 3 Low Pressure / Loss of Charge	X	X	Insufficient charge	Check for refrigerant leaks			
				X		Compressor pump down at start-up	Check charge and start-up water flow.
LT1 Fault Code 4 Water coil low temperature limit	X		Reduced or no water flow in heating	Check pump operation or water valve operation/setting. Plugged strainer or filter. Clean or replace..			
				Check water flow adjust to proper flow rate. Check antifreeze density with hydrometer.			
	X		Inadequate antifreeze level Improper temperature limit setting (30°F vs 10°F [-1°C vs -2°C])	Clip JW3 jumper for antifreeze (10°F [-12°C]) use.			
				Water Temperature out of range	Bring water temp within design parameters.		
				X	X	Bad thermistor	Check temp and impedance correlation per chart
LT2 Fault Code 5 Air coil low temperature limit		X	Reduced or no air flow in cooling	Check for dirty air filter and clean or replace. Check fan motor operation and airflow restrictions. Too high of external static. Check static vs blower table.			
				X		Air Temperature out of range	Too much cold vent air? Bring entering air temp within design parameters.
	X	X	Improper temperature limit setting (30°F vs 10°F [-1°C vs -12°C]) Bad thermistor	Normal airside applications will require 30°F [-1°C] only. Check temp and impedance correlation per chart.			
				X	X	Blocked drain	Check for blockage and clean drain.
Condensate Fault Code 6	X	X	Improper trap	Check trap dimensions and location ahead of vent. Check for piping slope away from unit.			
				X		Poor drainage	Check slope of unit toward outlet. Poor venting. Check vent location.
	X	X	Moisture on sensor Plugged air filter	Check for moisture shorting to air coil. Replace air filter.			
				x	X	Restricted Return Air Flow	Find and eliminate restriction. Increase return duct and/or grille size.
				X	X	Under Voltage	Check power supply and 24VAC voltage before and during operation. Check power supply wire size. Check compressor starting. Need hard start kit? Check 24VAC and unit transformer tap for correct power supply voltage.
	X	X	Over Voltage				Check power supply voltage and 24VAC before and during operation. Check 24VAC and unit transformer tap for correct power supply voltage.
	Unit Performance Code 8	X	X	Heating mode LT2>125°F [52°C]	Check for poor air flow or overcharged unit.		
Cooling Mode LT1>125°F [52°C] OR LT2< 40°F [4°C])				Check for poor water flow, or air flow.			
Swapped Thermistor Code 9	X	X	LT1 and LT2 swapped	Reverse position of thermistors			
No Fault Code Shown	X	X	No compressor operation	See "Only Fan Operates".			
			Compressor overload	Check and replace if necessary.			
			Control board	Reset power and check operation.			
Unit Short Cycles	X	X	Dirty air filter	Check and clean air filter.			
			Unit in "test mode"	Reset power or wait 20 minutes for auto exit.			
			Unit selection	Unit may be oversized for space. Check sizing for actual load of space.			
			Compressor overload	Check and replace if necessary			
Only Fan Runs	X	X	Thermostat position	Ensure thermostat set for heating or cooling operation.			
			Unit locked out	Check for lockout codes. Reset power.			
			Compressor Overload	Check compressor overload. Replace if necessary.			
			Thermostat wiring	Check thermostat wiring at heat pump. Jumper Y and R for compressor operation in test mode.			
Only Compressor Runs	X	X	Thermostat wiring	Check G wiring at heat pump. Jumper G and R for fan operation			
			X	X	Fan motor relay	Jumper G and R for fan operation. Check for Line voltage across BR contacts.	
	X	X	Fan motor	Check fan power enable relay operation (if present).			
				Check for line voltage at motor. Check capacitor.			
				Check thermostat wiring at heat pump. Jumper Y and R for compressor operation in test mode			
Unit Doesn't Operate in Cooling		X	Reversing valve	Set for cooling demand and check 24VAC on RV coil and at CXM/DXM2 board. If RV is stuck, run high pressure up by reducing water flow and while operating engage and disengage RV coil voltage to push valve.			
			X	Thermostat setup	Check for 'O' RV setup not 'B'.		
			X	Thermostat wiring	Check O wiring at heat pump. Jumper O and R for RV coil 'click'.		
		X	Thermostat wiring	Put thermostat in cooling mode. Check 24 VAC on O (check between C and O); check for 24 VAC on W (check between W and C). There should be voltage on O, but not on W. If voltage is present on W, thermostat may be bad or wired incorrectly.			

Performance Troubleshooting

Performance Troubleshooting	Htg	Clg	Possible Cause	Solution
Insufficient capacity/ Not cooling or heating	X	X	Dirty filter	Replace or clean.
	X		Reduced or no air flow in heating	Check for dirty air filter and clean or replace.
				Check fan motor operation and airflow restrictions.
				Too high of external static. Check static vs. blower table.
		X	Reduced or no air flow in cooling	Check for dirty air filter and clean or replace.
				Check fan motor operation and airflow restrictions.
				Too high of external static. Check static vs. blower table.
	X	X	Leaky duct work	Check supply and return air temperatures at the unit and at distant duct registers if significantly different, duct leaks are present.
	X	X	Low refrigerant charge	Check superheat and subcooling per chart.
	X	X	Restricted metering device	Check superheat and subcooling per chart. Replace.
		X	Defective reversing valve	Perform RV touch test.
X	X	Thermostat improperly located	Check location and for air drafts behind stat.	
X	X	Unit undersized	Recheck loads & sizing. Check sensible clg. load and heat pump capacity.	
X	X	Scaling in water heat exchanger	Perform scaling check and clean if necessary.	
X	X	Inlet water too hot or too cold	Check load, loop sizing, loop backfill, ground moisture.	
High Head Pressure	X		Reduced or no air flow in heating	Check for dirty air filter and clean or replace.
				Check fan motor operation and air flow restrictions.
				Too high of external static. Check static vs. blower table.
		X	Reduced or no water flow in cooling	Check pump operation or valve operation/setting.
	Check water flow. Adjust to proper flow rate.			
		X	Inlet water too hot	Check load, loop sizing, loop backfill, ground moisture.
	X		Air temperature out of range in heating	Bring return air temperature within design parameters.
		X	Scaling in water heat exchanger	Perform scaling check and clean if necessary.
X	X	Unit overcharged	Check superheat and subcooling. Re-weigh in charge.	
X	X	Non-condensables in system	Vacuum system and re-weigh in charge.	
X	X	Restricted metering device.	Check superheat and subcooling per chart. Replace.	
Low Suction Pressure	X		Reduced water flow in heating.	Check pump operation or water valve operation/setting.
				Plugged strainer or filter. Clean or replace.
				Check water flow. Adjust to proper flow rate.
	X		Water temperature out of range.	Bring water temperature within design parameters.
		X	Reduced air flow in cooling.	Check for dirty air filter and clean or replace.
				Check fan motor operation and air flow restrictions.
			Too high of external static. Check static vs. blower table.	
	X	Air temperature out of range	Too much cold vent air? Bring entering air temperature within design parameters.	
X	X	Insufficient charge	Check for refrigerant leaks.	
Low Discharge Air Temperature in Heating	X		Too high of air flow	Check fan motor speed selection and air flow chart.
	X		Poor performance	See 'Insufficient Capacity'
High humidity		X	Too high of air flow	Check fan motor speed selection and airflow chart.
		X	Unit oversized	Recheck loads & sizing. Check sensible clg load and heat pump capacity.

Start-Up Log Sheet

Installer: Complete unit and system checkout and follow unit start-up procedures in the IOM. Use this form to record unit information, temperatures and pressures during start-up. Keep this form for future reference.

Job Name: _____ **Street Address:** _____

Model Number: _____ **Serial Number:** _____

Unit Location in Building: _____

Date: _____ **Sales Order No:** _____

In order to minimize troubleshooting and costly system failures, complete the following checks and data entries before the system is put into full operation.

Fan Motor	Description	Value
PSC	Speed Tap	
CV ECM	CFM Setting	

Temperatures: F or C

Antifreeze: _____ %

Pressures: PSIG or kPa

Type: _____

	Cooling Mode	Heating Mode
Entering Fluid Temperature		
Leaving Fluid Temperature		
Temperature Differential		
Return-Air Temperature	DB	WB DB
Supply-Air Temperature	DB	WB DB
Temperature Differential		
Water Coil Heat Exchanger (Water Pressure IN)		
Water Coil Heat Exchanger (Water Pressure OUT)		
Pressure Differential		
Water Flow GPM		
Compressor		
Amps		
Volts		
Discharge Line Temperature		
Motor		
Amps		
Volts		

Allow unit to run 15 minutes in each mode before taking data.

Note: Never connect refrigerant gauges during startup procedures. Conduct water-side analysis using P/T ports to determine water flow and temperature difference. If water-side analysis shows poor performance, refrigerant troubleshooting may be required. Connect refrigerant gauges as a last resort.

Functional Troubleshooting

HEATING CYCLE ANALYSIS -

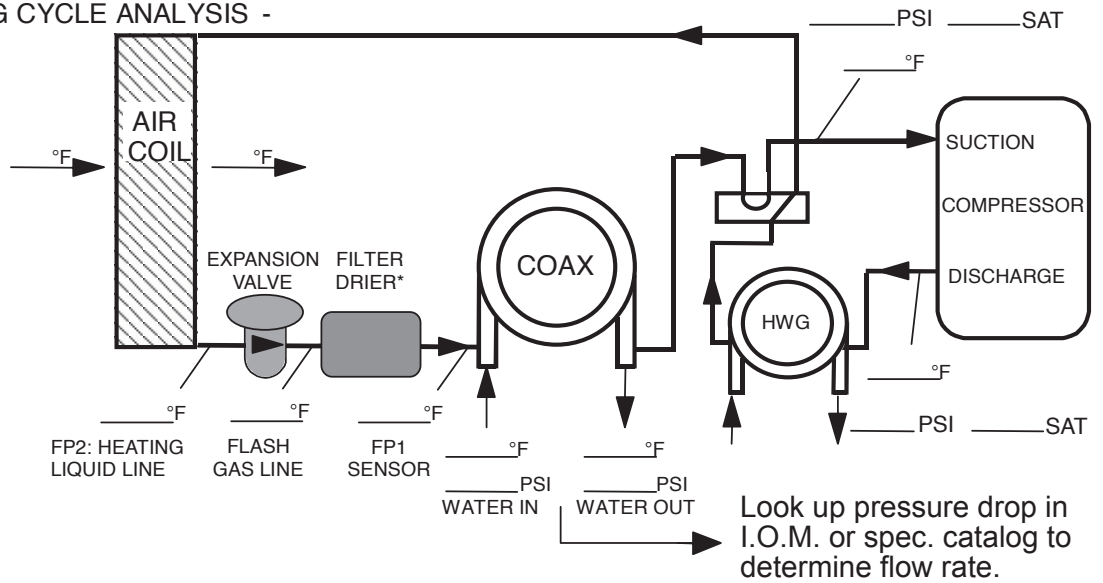

COOLING CYCLE ANALYSIS -

Refrigerant Type:

HFC-410A

Voltage: _____

Comp Amps: _____

Total Amps: _____

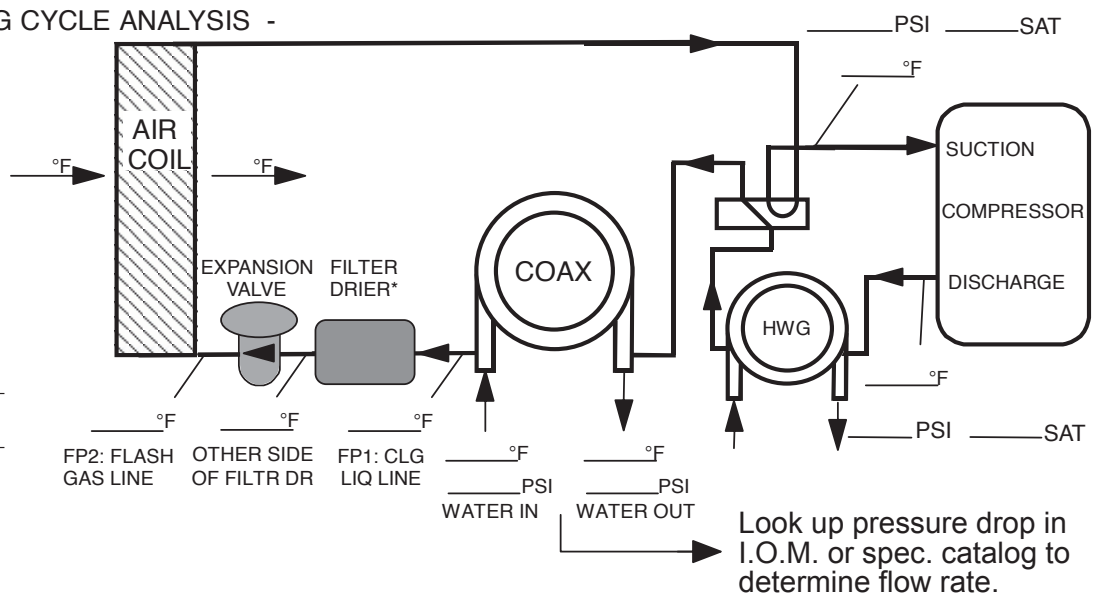

Heat of Extraction (Absorption) or Heat of Rejection =
 _____ flow rate (gpm) x _____ temp.diff. (deg. F) x _____ fluid factor[†] = _____ (Btu/hr)

Superheat = Suction temperature - suction saturation temp. = _____ (deg F)

Subcooling = Discharge saturation temp. - liquid line temp. = _____ (deg F)

[†] Use 500 for water, 485 for antifreeze.

Rev. 12/08

Note: Never connect refrigerant gauges during startup procedures. Conduct water-side analysis using P/T ports to determine water flow and temperature difference. If water-side analysis shows poor performance, refrigerant troubleshooting may be required. Connect refrigerant gauges as a last resort.

Notes:

Notes:

Notes:



**LIMITED EXPRESS WARRANTY -
HBH/HBV SERIES WATER-SOURCE HEAT PUMP - COMPACT**

Congratulations on purchasing your new HVAC equipment. It has been designed for long life and reliable service, and is backed by one of the strongest warranties in the industry. Your unit automatically qualifies for the warranty coverage listed below, provided you keep your proof of purchase (receipt) for the equipment and meet the warranty conditions.

LIMITED ONE (1) YEAR PARTS EXPRESS WARRANTY

MARS/Comfort-Aire/Century warrants all parts of the HBH/HBV water-source heat pump used in commercial applications to be free from defects in workmanship and materials for normal use and maintenance for one (1) year from the date of purchase by the original consumer for the original installation. This Express Limited Warranty applies only when the water-source heat pump is installed as part of a complete matched system, and only when the system is installed per Comfort-Aire/Century installation instructions and in accordance with all local, state and national codes for normal use.

LIMITED FIVE (5) YEAR EXTENDED EXPRESS WARRANTY ON COMPRESSOR

We will replace a compressor which proves to be defective for a period of five (5) years from date of heat pump purchase. All restrictions, limitations and procedures for the one year parts warranty apply to the additional compressor warranty period.

EXCEPTIONS

The Limited Express Warranty does not cover normal maintenance— Comfort-Aire/Century recommends that regular inspection/maintenance be performed at least once a season and proof of maintenance be kept. Additionally, labor charges, transportation charges for replacement parts, replacement of refrigerant or filters, any other service calls/repairs are not covered by this Limited Warranty. It also does not cover any portion or component of the system that is not supplied by Comfort-Aire/Century, regardless of the cause of failure of such portion or component.

CONDITIONS OF WARRANTY COVERAGE

- Unit must be operated according to Comfort-Aire/Century operating instructions included with the unit and cannot have been subjected to accident, alteration, improper repair, neglect or misuse, or an act of God (such as a flood)
- Serial numbers and/or rating plate have not been altered or removed
- Installation was done by a trained, licensed or otherwise qualified geothermal dealer/contractor
- Performance cannot be impaired by use of any product not authorized by Comfort-Aire/Century, or by any adjustments or adaptations to components
- Damage has not been a result of inadequate wiring or voltage conditions, use during brown-out conditions, or circuit interruptions
- Air flow around any section of the unit has not been restricted
- Unit remains in the original installation
- Unit was not purchased over the internet

DURATION OF WARRANTY & REGISTRATION

The warranty begins on the date of purchase by the original consumer. The consumer must register their product at www.marsdelivers.com within 90 days of purchase. The consumer must retain a receipted bill of sale as proof of warranty period. Without this proof, the express warranty begins on the date of shipment from the factory.

REMEDY PROVIDED BY THE LIMITED EXPRESS WARRANTY

The sole remedy under the Limited Warranty is replacement of the defective part. If replacement parts are required within the period of this warranty, Comfort-Aire/Century replacement parts shall be used; any warranty on the replacement part(s) shall not affect the applicable original unit warranty. Labor to diagnose and replace the defective part is not covered by this Limited Express Warranty. Access to the unit for service is the owner's responsibility. If for any reason the replacement part/product is no longer available during the warranty period, Comfort-Aire/Century shall have the right to allow a credit in the amount of the current suggested retail price of the part/product instead of providing repair or replacement.

LIMITATION OF LIABILITY

1. **EXCLUSION OF ALL IMPLIED WARRANTIES AND LIMITATION.** There are no other express or implied warranties. Comfort-Aire/Century makes no warranty of merchantability. We do not warrant that the unit is suitable for any particular purpose or can be used in buildings or rooms of any particular size or condition except as specifically provided in this document. There are no other warranties, express or implied, which extend beyond the description in this document.
2. All warranties implied by law are limited in duration to the five-year term of the Parts Warranty. Your exclusive remedy is limited to the replacement of defective parts. **We will not be liable for any consequential or incidental damages caused by any defect in this unit.**
3. This warranty gives you specific legal rights and you may also have other rights which vary from state to state. Some states do not allow limitation on how long an implied warranty lasts or do not allow the exclusion or limitation of incidental or consequential damages, so the above limitations or exclusions may not apply to you.
4. No warranties are made for units sold outside the continental United States and Canada. Your distributor or final seller may provide a warranty on units sold outside these areas.
5. Comfort-Aire/Century will not be liable for damages if our performance regarding warranty resolution is delayed by events beyond our control including accident, alteration, abuse, war, government restrictions, strikes, fire, flood, or other acts of God.

Please follow the below steps to register your product.

- **Please log onto our website www.marsdelivers.com**
- **Resources**
- **Product Registration**
- **Complete the requested information in all caps, especially the Email Address**
- **Press the "Continue" button at the bottom**
- **A copy of the registration will be sent to the email address that you entered at the top of the page for your records**

KEEP THIS INFORMATION AS A RECORD OF YOUR PURCHASE

Apply Serial Number and Model Number sticker here (from product carton). If unavailable, write serial number and model number below (can be found on unit rating plate).

Date of Purchase _____ Date Installation Completed _____

Component of new HVAC system Replacement heat pump only

Remember to retain your bill of sale as proof of warranty period and ownership.



Revision History

Date:	Item:	Action:
07/08/21	All	Added Polymer drain pan
07/07/20	Pgs. 22-23, 27-28 and 52	Added Note 11 and 6, Updated Wiring Diagram Matrix
06/05/20	Page 77	Updated Start-Up Log Sheet
5/20/20	Pgs 20, 21, 24, 25, 26, 29	Added Dimensional Data from Submittal
5/13/20	All	Replaced DXM with DXM2 controls, updated all data tables
8/21/18	Page 31	Updated size 041 rated airflow
11/2/17	Page 58	Added WSE DIP setting table
07/25/17	Page 7	Update hanger and mounting instructions
06/14/17	Page 34	Update drawing
1/30/17	Page 22, 23	Update notes
10/6/16	Page 7	Text Update
10/4/16	WSE right hand Field Fabricated Tube	Corrected
9/27/16	HBH WSE Dim Q	Corrected
9/7/16	Page,24	Updated voltage codes size 041
05/16/16	Table- corrected centimeters in dimensional tables	Updated
04/15/16	Text	Updated
2/24/16	Pages 30, 31	EMC Blower Performance information,
02/06/15	Page 3	Changed E-Coated to Tin-Plated
01/27/16	All	Added WSE Information
01/21/15	All	Added ECM Information
06/16/14	Pages 8, 11 & 19	Change Text - Filter "rack" to "frame"
05/29/14	Physical Data Table	Removed Fan Motor (hp)
05/12/14	Physical Data Table and Water Quality Table	Updated Ref. Charge on 024 and Unit Maximum Working Water Pressure; Updated Water Quality Table

Due to ongoing product improvements, specifications and dimensions are subject to change and correction without notice or incurring obligations. Determining the application and suitability for use of any product is the responsibility of the installer. Additionally, the installer is responsible for verifying dimensional data on the actual product prior to beginning any installation preparations.

Incentive and rebate programs have precise requirements as to product performance and certification. All products meet applicable regulations in effect on date of manufacture; however, certifications are not necessarily granted for the life of a product. Therefore, it is the responsibility of the applicant to determine whether a specific model qualifies for these incentive/rebate programs.



1900 Wellworth Ave., Jackson, MI 49203 • Ph. 517-787-2100 • www.marsdelivers.com



97B0016N10