

NO. **921**



Established in 1946

**Proudly  
Manufactured  
in the USA**

**SOLD ONLY  
THROUGH  
WHOLESALEERS**

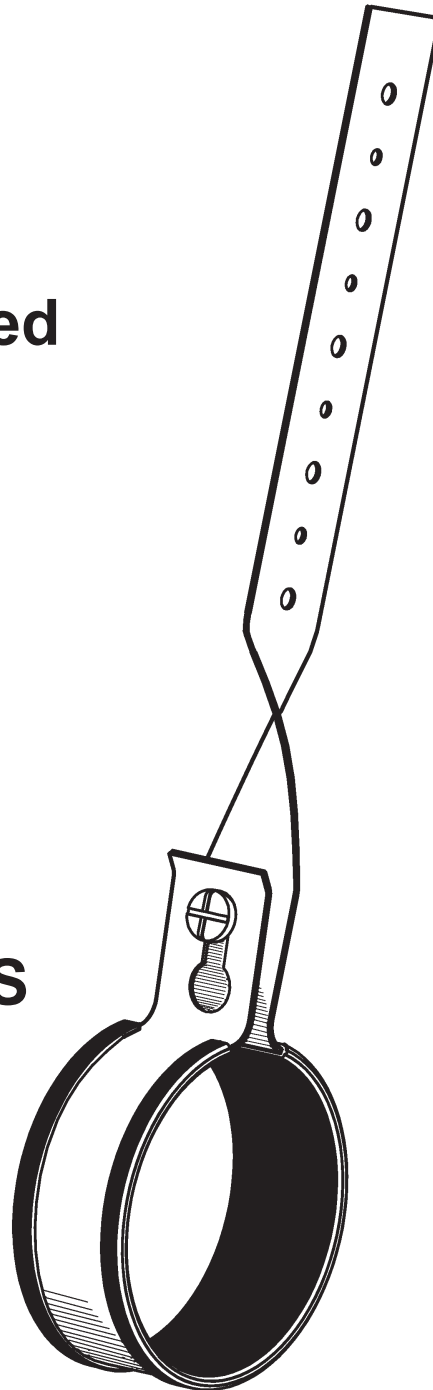

www.gfm.biz  
9800 Bustleton Ave  
Philadelphia, PA

tel: 215-535-4141  
fax: 215-537-5161

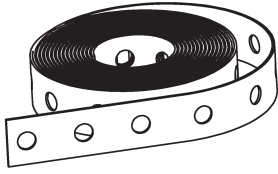

Strapping  
page 1

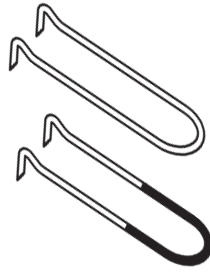

Hooks  
page 2

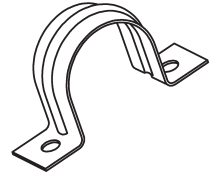

2 Hole Straps  
page 3,4



1 Hole Straps  
page 3,4

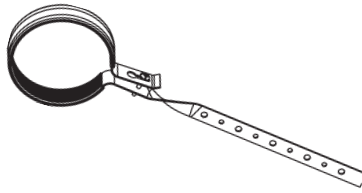

Greenfield Hangers  
page 5

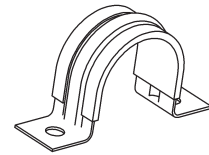

Plastic Coated Hangers  
page 6

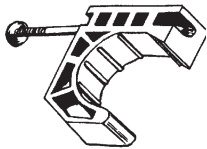

Plastic Clamps  
page 7

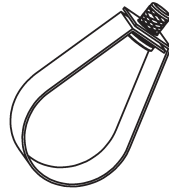

Swivels  
page 8

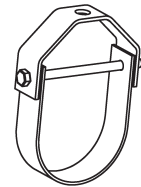

Clevis Hangers  
page 9

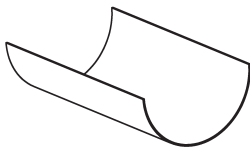

Shields  
page 10

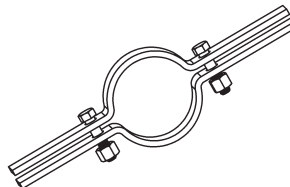

Riser Clamps  
page 10

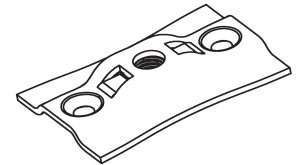

Bowtie Flanges  
page 11

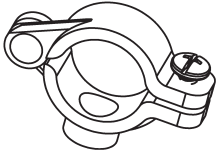

Split Ring Hangers  
page 11



Beam Clamps  
page 12

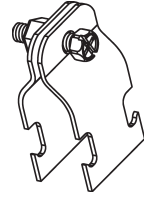

Strut Hardware  
page 13-14

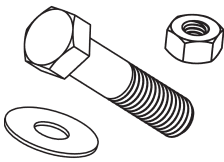

Hardware  
page 15-16

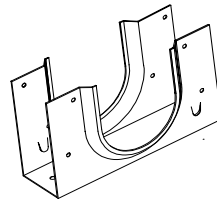

Stud Shoe  
page 18



16 Hole Plates  
page 18

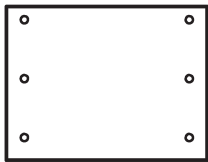

Protector/BOCA Plates  
page 19



FHA Plates  
page 19

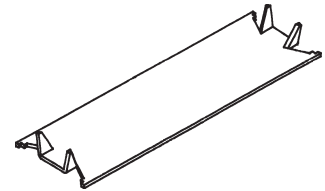

Stud Guards  
page 20

Full Index on back cover

# Perforated Hanger Strapping

List Price per Coil

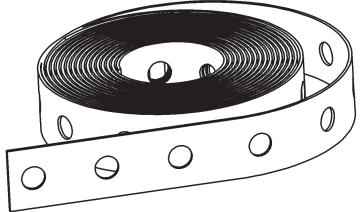
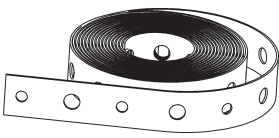
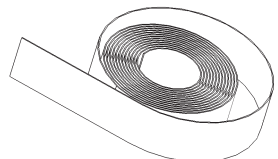
|   | Width X<br>Gauge | Wt / Mft | List Price per Coil |                 |                 |
|---|------------------|----------|---------------------|-----------------|-----------------|
|   |                  |          | Bulk<br>10 ft       | Boxed<br>50 ft  | Boxed<br>100 ft |
| <b>Galvanized</b><br>1/4 bolt holes<br><br><br><b>fig. 971</b>                           | 3/4 X 28         | 38       | 1.40                | 8.35            | 15.60           |
|   | 3/4 X 24         | 58       | 1.65                | 9.60            | 18.15           |
|   | 3/4 X 22         | 72       | 1.90                | 10.85           | 20.60           |
|   | 3/4 X 20         | 80       | 2.15                | 12.20           | 23.35           |
|   | 3/4 X 18         | 110      | 4.95                | ---             | ---             |
|   | 1 X 14           | 220      | 13.10               | 20 pcs per Bndl |                 |
|   | 1-1/4 X 12       | 400      | 20.65               | 10 pcs per Bndl |                 |
| <b>Steel Plain</b><br>1/4 bolt holes<br><br><b>fig. 970</b>   | 3/4 X 24         | 58       | 1.60                | 9.25            | 17.45           |
|   | 3/4 X 20         | 80       | 1.85                | 10.80           | 20.50           |
| <b>Galvanized Duct Tape</b><br>Alternate bolt and nail holes<br><br><br><b>fig. 101</b> | 3/4 X 28         | 38       | 1.40                | 8.35            | 15.60           |
|   | 3/4 X 24         | 58       | 1.65                | 9.60            | 18.10           |
|   | 3/4 X 22         | 72       | 1.90                | 10.85           | 20.60           |
| <b>Copperclad</b><br><br><b>fig. 972</b>  | 3/4 X 24         | 58       | 4.00                | 21.60           | 43.30           |
| <b>Pure Copper</b><br><br><b>fig. 974</b>   | 3/4 X 22         | 80       | 24.95               | 124.70          | 25' =<br>62.35  |
| <b>Stainless</b><br><br><b>fig. 975</b>   | 3/4 X 22         | 72       | 14.45               | 72.20           | ---             |
| <b>Plastic - polypropylene</b><br><br><b>fig. 102</b>   | 3/4 X .050       | 15       | See page 7.         |                 |                 |
| <b>No Hole Strapping (Duct Strap)</b><br><br><br><b>fig. 106</b>                       | 1 X 30           | 4.6 ea   | ---                 | ---             | 15.75           |
|   | 1-1/2 X 30       | 6.9 ea   | ---                 | ---             | 23.65           |
|   | 1 X 26           | 6.4 ea   | ---                 | ---             | 19.65           |
|   | 1-1/2 X 26       | 9.6 ea   | ---                 | ---             | 28.85           |
|   | 2 X 26           | 12.8 ea  | ---                 | ---             | 38.00           |
|   | 1 X 22           | 10.8 ea  | ---                 | ---             | 23.60           |

Packaging: 500 Ft / Ctn ; 20 ga - 10 Ft packed 25 rolls / ctn

# Tube & Pipe Hooks

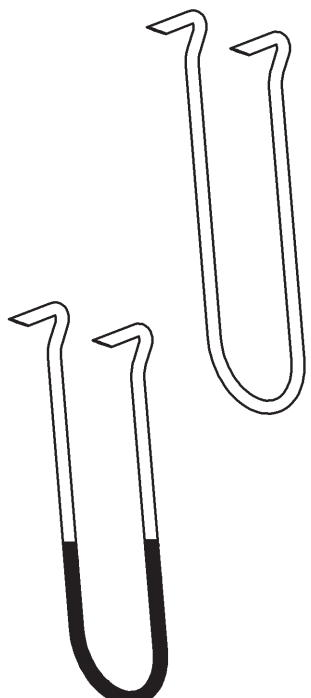
|   |  | Size X Length | List Price Each   |                         |                |
|---|--|---------------|-------------------|-------------------------|----------------|
|   |  |               | Pipe Bright Steel | Copper Tube Copper-clad | Plastic Coated |
| <b>Bright Steel</b> <b>fig. 197</b><br><b>Copperclad</b> <b>fig. 198</b><br><b>Plastic Coated</b> <b>fig. 199</b> |  | 1/2 X 4       | .25               | .31                     | .91            |
|   |  | 3/4 X 4       | .25               | .31                     | .91            |
|   |  | 1 X 4         | .25               | .31                     | .91            |
|   |  | 1/2 X 6       | .28               | .34                     | .97            |
|   |  | 3/4 X 6       | .28               | .34                     | .97            |
|   |  | 1 X 6         | .28               | .34                     | .97            |
|   |  | 1-1/4 X 6     | .45               | .34                     | 1.80           |
|   |  | 1-1/2 X 6     | .45               | .56                     | 1.80           |
|   |  | 2 X 6         | .45               | .56                     | 1.80           |
|   |  | 1/2 X 8       | .33               | .42                     | 1.40           |
|   |  | 3/4 X 8       | .33               | .42                     | 1.40           |
|   |  | 1 X 8         | .33               | .42                     | 1.40           |
|   |  | 1-1/4 X 8     | .54               | .42                     | 2.40           |
|   |  | 1-1/2 X 8     | .54               | .60                     | 2.40           |
|   |  | 2 X 8         | .54               | .60                     | 2.40           |



**Weight Per 1000 Hooks:**

4" - 50 lbs  
6" - 64 lbs  
8" - 80 lbs

**Packaging:** 50 Hooks per box

For plastic coated steel pipe hooks order Tube hook of next larger size  
Example: For 3/4 X 6 pipe - use 1 X 6 tube

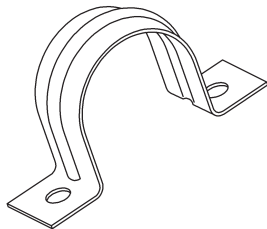
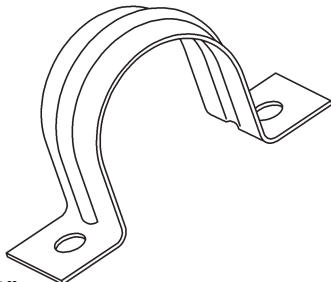
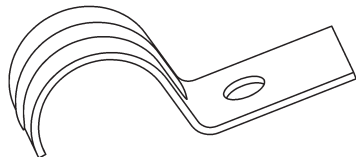
# Copper Tube Straps



|  | Size       | Weight Per 1000 | Quantity Box / Ctn | List Price Each |
|--|------------|-----------------|--------------------|-----------------|
| <b>Copperclad, Two Hole</b><br><br><b>fig. 500</b>  | 1/4        | 6.5             | 100/2M             | .079            |
|  | 3/8        | 7               | 100/2M             | .082            |
|  | 1/2        | 7.6             | 100/2M             | .082            |
|  | 3/4        | 11              | 100/1M             | .091            |
|  | 1          | 14              | 100                | .131            |
|  | 1-1/4      | 35              | 100                | .250            |
|  | 1-1/2      | 45              | 100                | .322            |
|  | 2          | 50              | 100                | .355            |
| <b>Copper Plated Nails</b><br><b>fig. 509</b>  | 13 GA X 1  | 2.3             | 200 / Bag          | .019            |
| <b>Pure Copper, Two Hole</b><br><br>2-1/2" - 4"<br>available upon request<br><b>fig. 503</b> | 1/8        | 6               | 100/1M             | .26             |
|  | 1/4        | 6               | 100/1M             | .26             |
|  | 3/8        | 7               | 100/1M             | .26             |
|  | 1/2        | 8               | 100/1M             | .28             |
|  | 3/4        | 11              | 100/1M             | .33             |
|  | 1          | 14              | 100/1M             | .50             |
|  | 1-1/4      | 35              | 25                 | 1.05            |
|  | 1-1/2      | 45              | 25                 | 1.25            |
|  | 2          | 50              | 25                 | 1.50            |
| <b>Copperclad, One Hole</b><br><br><b>fig. 510</b>  | 1/8        | 13              | 100/2M             | .22             |
|  | 1/4        | 15              | 100/1M             | .22             |
|  | 3/8        | 20              | 100/1M             | .22             |
|  | 1/2        | 25              | 100/1M             | .24             |
|  | 3/4        | 55              | 100/1M             | .26             |
|  | 1          | 67              | 100                | .50             |
|  | 1-1/4      | 85              | 50                 | 1.06            |
|  | 1-1/2      | 125             | 50                 | 1.18            |
|  | 2          | 200             | 50                 | 1.38            |
| <b>J-TubeNailer Copperclad</b><br>* one nailer for both sizes<br><br><b>fig. 540</b>        | 1/2 & 3/4* | 19              | 100/2M             | .19             |

# Pipe Straps

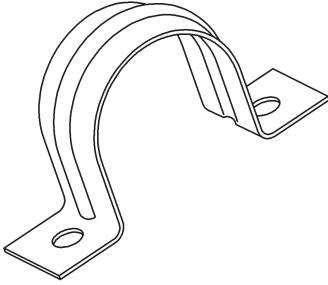
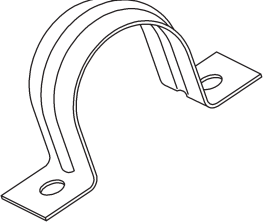
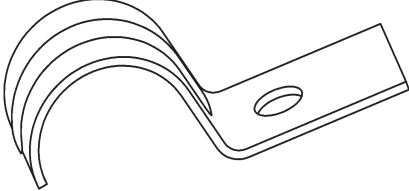
## EMT Straps

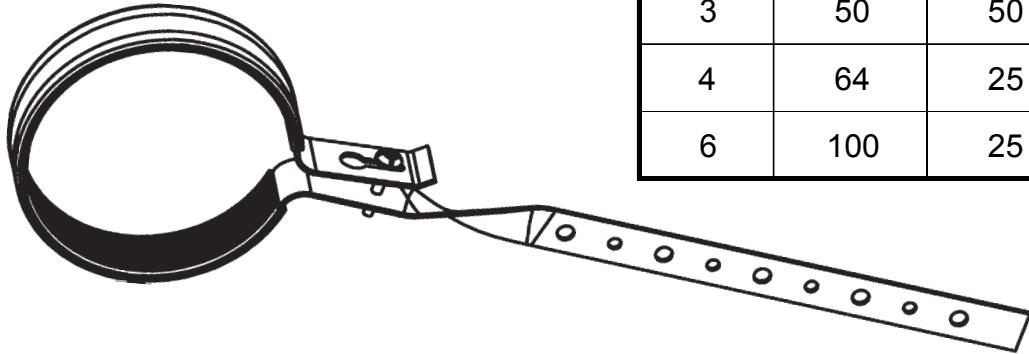
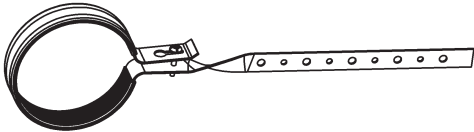

|  | Size<br>Inches | Weight<br>Per 1000 | Carton<br>Quantity | List Price<br>Each |      |
|--|----------------|--------------------|--------------------|--------------------|------|
| <b>Pipe Straps,<br/>Two Hole, Galvanized</b><br><br><br><br><b>fig. 600</b>   | 1/4            | 13                 | 100                | .09                |      |
|  | 3/8            | 25                 | 100                | .09                |      |
|  | 1/2            | 30                 | 100                | .10                |      |
|  | 3/4            | 38                 | 100                | .13                |      |
|  | 1              | 83                 | 100                | .25                |      |
|  | 1-1/4          | 110                | 50                 | .33                |      |
|  | 1-1/2          | 125                | 50                 | .45                |      |
|  | 2              | 200                | 50                 | .66                |      |
|  | 2-1/2          | 250                | 25                 | 1.05               |      |
|  | 3              | 330                | 25                 | 1.18               |      |
|  | 4              | 400                | 25                 | 1.77               |      |
|  | 6              | 840                | 25                 | 5.25               |      |
| 8  | 1500           | 10                 | 18.40              |                    |      |
| <b>Pipe Straps,<br/>Two Hole, Stainless (18-8)</b><br><br><br><br><b>fig. 760</b>                                 | 1/4            | 13                 | 100                | 3.61               |      |
|  | 3/8            | 25                 | 100                | 3.61               |      |
|  | 1/2            | 34                 | 100                | 3.61               |      |
|  | 3/4            | 45                 | 100                | 4.46               |      |
|  | 1              | 80                 | 50                 | 5.58               |      |
|  | 1-1/4          | 110                | 50                 | 6.56               |      |
|  | 1-1/2          | 125                | 50                 | 7.20               |      |
|  | 2              | 170                | 25                 | 8.65               |      |
|  | 2-1/2          | 250                | 25                 | 13.90              |      |
|  | 3              | 300                | 25                 | 15.75              |      |
| 4  | 400            | 25                 | 19.70              |                    |      |
| <b>Pipe / EMT Straps,<br/>One Hole, Galvanized</b><br><br><br><br><b>fig. 610 - Pipe</b><br><b>fig. 620 - EMT</b> |                |                    |                    | PIPE               | EMT  |
|  | 1/4            | 20                 | 100                | .13                | ---  |
|  | 3/8            | 25                 | 100                | .16                | ---  |
|  | 1/2            | 55                 | 100                | .19                | .18  |
|  | 3/4            | 95                 | 100                | .32                | .20  |
|  | 1              | 100                | 100                | .37                | .25  |
|  | 1-1/4          | 125                | 100                | .59                | .43  |
|  | 1-1/2          | 200                | 50                 | 1.00               | .60  |
|  | 2              | 250                | 50                 | 1.18               | 1.18 |
|  | 2-1/2          | 500                | 25                 | 5.90               | 5.90 |
| 3  | 1000           | 25                 | 7.90               | 7.90               |      |
| 4  | 1500           | 25                 | 11.80              | 11.80              |      |

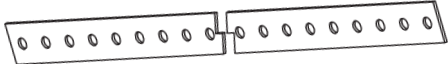
# Greenfield DWV Hangers

|  | Size<br>Inches | Weight<br>Per 100 | Quantity<br>Per Ctn | List Price<br>Each |
|--|----------------|-------------------|---------------------|--------------------|
| <b>Greenfield Hanger,<br/>Plastic Coated</b><br><br>   | 1-1/2          | 30                | 50                  | 2.63               |
|  | 2              | 35                | 50                  | 2.75               |
|  | 3              | 50                | 50                  | 3.05               |
|  | 4              | 64                | 25                  | 3.45               |
|  | 6              | 100               | 25                  | 11.25              |
| Material Width = 1.0" <span style="float: right;"><b>fig. 220</b></span>   |                |                   |                     |                    |
| <b>LW Greenfield Hanger,<br/>Plastic Coated</b><br><br>   | 1-1/2          | 28                | 50                  | 2.25               |
|  | 2              | 32                | 50                  | 2.44               |
|  | 3              | 36                | 50                  | 2.63               |
|  | 4              | 46                | 25                  | 2.94               |
| Material Width = 3/4" <span style="float: right;"><b>fig. 320</b></span>   |                |                   |                     |                    |
| <b>Greenfield Hanger,<br/>Galvanized, Uncoated</b><br><br>  | 1-1/2          | 27                | 50                  | 1.38               |
|  | 2              | 30                | 50                  | 1.51               |
|  | 3              | 34                | 50                  | 1.58               |
|  | 4              | 44                | 50                  | 1.77               |
| Material Width = 3/4" <span style="float: right;"><b>fig. 120</b></span>   |                |                   |                     |                    |
| <b>DWV Extension Bar, Galvanized</b><br><br><br>16 Gauge <span style="float: right;"><b>fig. 221</b></span> | 1" x 36"       | 63                | 25                  | 1.70               |

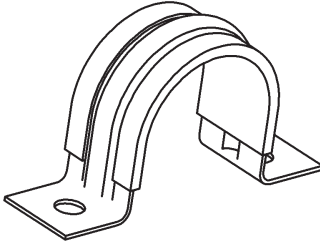
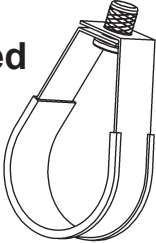
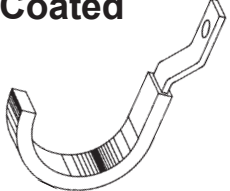
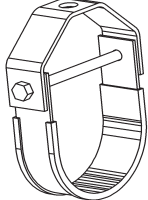

# Plastic Coated Hangers

|   | Size<br>Inches | Weight<br>Per 100 | Quantity<br>Per Ctn | List Price<br>Each |
|---|----------------|-------------------|---------------------|--------------------|
| <b>Straps, Plastic Coated</b><br><br><br><br><b>fig. 603</b>   | 1/2            | 4                 | 50                  | 1.70               |
|   | 3/4            | 5                 | 50                  | 1.70               |
|   | 1              | 10                | 50                  | 1.88               |
|   | 1-1/4          | 11                | 50                  | 2.00               |
|   | 1-1/2          | 11                | 50                  | 2.20               |
|   | 2              | 14                | 50                  | 2.30               |
|   | 3              | 34                | 25                  | 4.00               |
|   | 4              | 40                | 25                  | 5.00               |
|   | 6              | 80                | 10                  | 13.25              |
|   | 8              | 150               | 10                  | 27.50              |
| <b>Adjustable Swivel Ring, Plastic Coated</b><br><br><br><br>1/2" - 1-1/4"<br>available upon request<br><br><b>fig. 302</b> | 1-1/2          | 17                | 50                  | 3.00               |
|   | 2              | 16                | 50                  | 3.15               |
|   | 3              | 33                | 25                  | 4.85               |
|   | 4              | 60                | 25                  | 6.25               |
|   | 6              | 125               | 20                  | 10.35              |
|   | 8              | 150               | 10                  | 25.00              |
| <b>J-Hanger, Plastic Coated</b><br><br><br><br><b>fig. 113</b>   | 1-1/2          | 80                | 25                  | 5.65               |
|   | 2              | 80                | 25                  | 5.65               |
|   | 3              | 93                | 25                  | 7.60               |
|   | 4              | 105               | 25                  | 8.65               |
|   | 6              | 270               | 10                  | 52.50              |
| <b>Clevis, Plastic Coated</b><br><br><br><br>1/2" - 1-1/4"<br>available upon request<br><br><b>fig. 404</b>                | 1-1/2          | 33                | 25                  | 2.85               |
|   | 2              | 38                | 25                  | 3.25               |
|   | 3              | 70                | 25                  | 5.50               |
|   | 4              | 110               | 25                  | 7.15               |
|   | 6              | 350               | 10                  | 21.25              |
|   | 8              | 500               | 10                  | 30.00              |
| <b>Riser Clamps, Plastic Coated</b><br><br><br><br><b>fig. 107</b>   | 1-1/2          | 100               | 25                  | 9.05               |
|   | 2              | 100               | 25                  | 9.05               |
|   | 3              | 120               | 25                  | 11.25              |
|   | 4              | 150               | 25                  | 16.25              |
|   | 6              | 450               | 10                  | 24.95              |

# Plastic Hangers

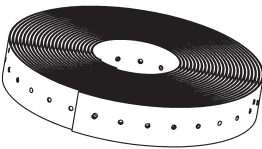
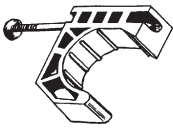
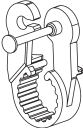
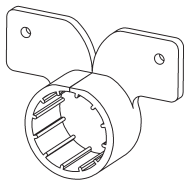
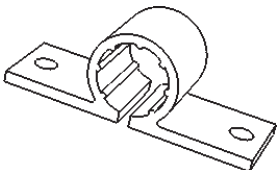
|  | Size  | Weight Per 100 | Quantity Box / Ctn | List Price Each |
|--|-------|----------------|--------------------|-----------------|
| <b>Plastic Strapping Polypropylene</b><br><br>1/8 Dia. Holes<br>Max working load, 15# @ -20 °F. to 120 °F.<br>Breaking strength, 100# @ 68 °F.<br><b>fig. 102</b> | 10'   | 15             | bulk / 100         | 1.84            |
|  | 25'   | 37             | 1 / 40             | 3.68            |
|  | 50'   | 75             | 1 / 20             | 7.35            |
|  | 100'  | 150            | 1 / 10             | 14.57           |
| <b>Plastic Half Clamp</b><br><br>C. T. Size<br>Material: HDPE<br><b>fig. 511</b>  | 1/2   | 1.0            | 100 / 1M           | .165            |
|  | 3/4   | 1.5            | 100 / 1M           | .185            |
|  | 1     | 2.2            | 50 / 250           | .58             |
| <b>Single Shot</b><br><br>C. T. Size<br>Material: Copper Safe PP<br><b>fig. 513</b>   | 1/2   | 1.7            | 50 / 500           | .50             |
|  | 3/4   | 1.9            | 50 / 500           | .63             |
| <b>Suspension Clamp</b><br><br>C. T. Size<br>Material: PP<br><b>fig. 515</b>  | 1/2   | 1.0            | 100 / 1M           | .34             |
|  | 3/4   | 1.5            | 100 / 1M           | .38             |
|  | 1     | 1.5            | 50 / 250           | 1.05            |
|  | 1-1/4 | 1.6            | 25 / 250           | 2.56            |
|  | 1-1/2 | 1.7            | 25 / 250           | 2.76            |
|  | 2     | 2.0            | 25 / 250           | 3.61            |
| <b>2 - Hole Plastic Tube Clamp</b><br><br>C. T. Size<br>Material: PP<br><b>fig. 517</b>   | 1/2   | 1.0            | 100 / 500          | .43             |
|  | 3/4   | 1.1            | 100 / 500          | .47             |
|  | 1     | 1.4            | 50 / 250           | 1.12            |
|  | 1-1/4 | 1.6            | 25 / 250           | 1.31            |
|  | 1-1/2 | 1.8            | 25 / 250           | 1.64            |
|  | 2     | 2.4            | 25 / 250           | 2.23            |

# Hangers

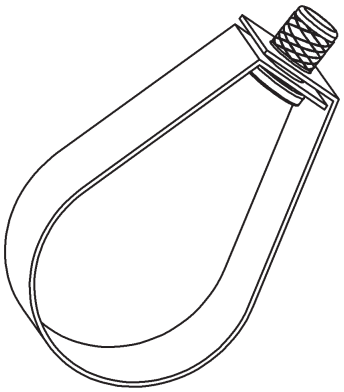
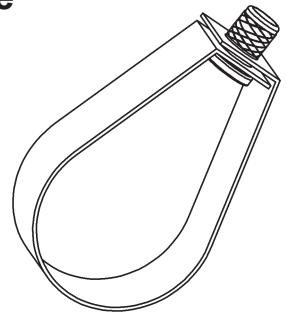
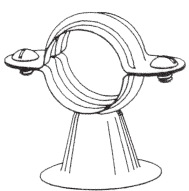
|  | Size<br>Inches | Weight<br>Per 100 | Quantity<br>Per Ctn | List Price<br>Each |
|--|----------------|-------------------|---------------------|--------------------|
| <b>Adj. Swivel Ring,<br/>Galvanized<br/>IPS</b>  <p>1/2" to 4" - 3/8 Rod<br/>5" to 8" - 1/2 Rod</p> <p style="text-align: right;"><b>fig. 300</b></p> | 1/2            | 11                | 100                 | 1.18               |
|  | 3/4            | 11                | 100                 | 1.18               |
|  | 1              | 11                | 100                 | 1.25               |
|  | 1-1/4          | 12                | 100                 | 1.29               |
|  | 1-1/2          | 13                | 100                 | 1.34               |
|  | 2              | 14                | 100                 | 1.42               |
|  | 2-1/2          | 28                | 50                  | 2.63               |
|  | 3              | 32                | 50                  | 3.02               |
|  | 4              | 55                | 25                  | 4.20               |
|  | 5              | 60                | 25                  | 5.51               |
|  | 6              | 60                | 20                  | 6.23               |
|  | 8              | 140               | 10                  | 8.65               |
| <b>Adj. Swivel Ring,<br/>Copper Tube</b>  <p>1/2" to 4" - 3/8 Rod</p> <p style="text-align: right;"><b>fig. 301</b></p>                             | 1/2            | 11                | 100                 | 1.39               |
|  | 3/4            | 11                | 100                 | 1.42               |
|  | 1              | 11                | 100                 | 1.47               |
|  | 1-1/4          | 12                | 100                 | 1.50               |
|  | 1-1/2          | 13                | 100                 | 1.52               |
|  | 2              | 14                | 100                 | 1.67               |
|  | 2-1/2          | 16                | 50                  | 2.78               |
|  | 3              | 28                | 50                  | 5.25               |
|  | 4              | 36                | 25                  | 6.04               |
| <b>Bell Hanger</b><br>C. T. Size<br>Epoxy Coated Steel  <p style="text-align: right;"><b>fig. 430</b></p>   | 1/2            | 6                 | 25 / 500            | 1.31               |
|  | 3/4            | 6                 | 25 / 500            | 1.44               |
|  | 1              | 6                 | 25 / 500            | 1.58               |
|  | 1-1/4          | 7                 | 25                  | 2.10               |
|  | 1-1/2          | 8                 | 25                  | 2.90               |
|  | 2              | 10                | 25                  | 4.20               |

# Clevis Hangers

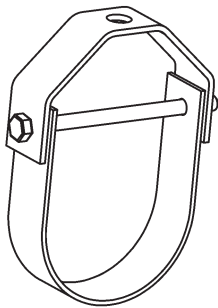
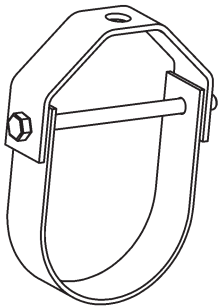
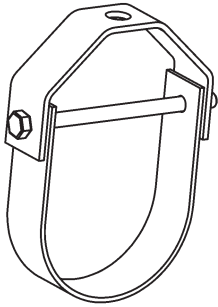
|  | Size<br>Inches | Weight<br>Per 100 | Quantity<br>Per Ctn | List Price<br>Each |
|--|----------------|-------------------|---------------------|--------------------|
| <b>Light Clevis</b><br><br><b>fig. 104</b>  | 1/2            | 13                | 100                 | 0.98               |
|  | 3/4            | 14                | 100                 | 1.03               |
|  | 1              | 18                | 100                 | 1.08               |
|  | 1-1/4          | 22                | 100                 | 1.12               |
|  | 1-1/2          | 28                | 100                 | 1.22               |
|  | 2              | 35                | 50                  | 1.35               |
|  | 2-1/2          | 65                | 25                  | 2.50               |
|  | 3              | 65                | 25                  | 2.63               |
|  | 4              | 110               | 25                  | 3.28               |
| <b>Clevis, Copper Tube<br/>Copper Plated</b><br><br><b>fig. 406</b>  | 1/2            | 10                | 100                 | 1.29               |
|  | 3/4            | 10                | 100                 | 1.31               |
|  | 1              | 12                | 100                 | 1.48               |
|  | 1-1/4          | 18                | 100                 | 1.58               |
|  | 1-1/2          | 24                | 100                 | 1.67               |
|  | 2              | 36                | 50                  | 1.90               |
|  | 2-1/2          | 41                | 25                  | 4.33               |
|  | 3              | 50                | 25                  | 4.95               |
|  | 4              | 100               | 25                  | 6.08               |
|  | 5              | 198               | 25                  | 19.00              |
|  | 6              | 220               | 25                  | 21.00              |
| <b>Standard Clevis<br/>Available to 28"</b><br><br>Plain - <b>fig. 204</b><br>Add 50% Zinc Plated - <b>fig. 304</b> | 1/2            | 18                | 100                 | 1.21               |
|  | 3/4            | 22                | 100                 | 1.21               |
|  | 1              | 25                | 100                 | 1.34               |
|  | 1-1/4          | 35                | 100                 | 1.50               |
|  | 1-1/2          | 35                | 100                 | 1.58               |
|  | 2              | 42                | 50                  | 1.81               |
|  | 2-1/2          | 84                | 25                  | 3.47               |
|  | 3              | 98                | 25                  | 3.47               |
|  | 4              | 170               | 25                  | 4.70               |
|  | 5              | 250               | 15                  | 6.75               |
|  | 6              | 330               | 10                  | 8.25               |
|  | 8              | 500               | 10                  | 14.70              |
|  | 10             | 900               | bulk                | 32.33              |
|  | 12             | 1100              | bulk                | 42.00              |

# Hangers

**Size**    **Weight**    **Quantity**    **List Price**  
**Inches**    **Per 100**    **Per Ctn**    **Each**

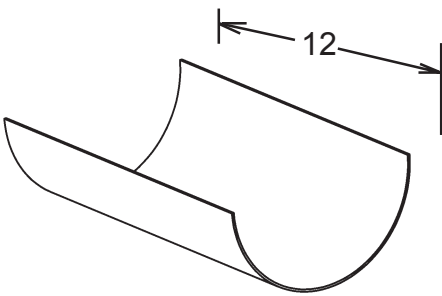
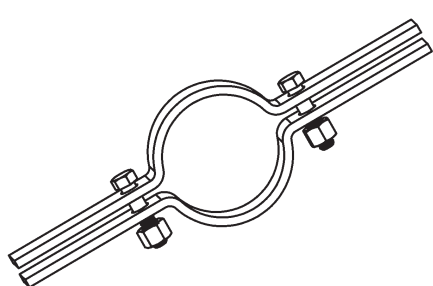
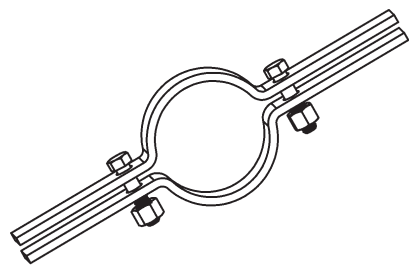
|  |  | O.D.  | GAGE | CLEVIS SIZE |       |      |       |
|--|--|-------|------|-------------|-------|------|-------|
| <b>Shields, Insulation Galvanized</b><br><br><br><b>fig. 105</b>  |  | 1.9   | 18   | 1-1/2       | 64    | 50   | 3.92  |
|  |  | 2.4   | 18   | 2           | 64    | 50   | 4.53  |
|  |  | 2.9   | 18   | 2-1/2       | 76    | 50   | 4.98  |
|  |  | 3.5   | 18   | 3           | 92    | 50   | 5.75  |
|  |  | 4.5   | 18   | 4           | 120   | 50   | 7.15  |
|  |  | 5.6   | 18   | 5           | 160   | 25   | 9.65  |
|  |  | 6.7   | 18   | 6           | 180   | 25   | 12.10 |
|  |  | 8.7   | 18   | 8           | 280   | 25   | 16.00 |
|  |  | 10.8  | 18   | 10          | 350   | bulk | 20.75 |
|  |  | 12.8  | 18   | 12          | 420   | bulk | 26.00 |
| <b>Riser Clamp, Iron Pipe Size</b><br><br><br>Plain - <b>fig. 108</b><br>Add 50% Zinc Plated - <b>fig. 308</b> |  | 1/2   |      |             | 80    | 25   | 3.54  |
|  |  | 3/4   |      |             | 80    | 25   | 3.54  |
|  |  | 1     |      |             | 80    | 25   | 3.68  |
|  |  | 1-1/4 |      |             | 110   | 25   | 4.20  |
|  |  | 1-1/2 |      |             | 125   | 25   | 4.33  |
|  |  | 2     |      |             | 140   | 25   | 4.63  |
|  |  | 2-1/2 |      |             | 170   | 25   | 5.45  |
|  |  | 3     |      |             | 190   | 25   | 5.90  |
|  |  | 4     |      |             | 210   | 25   | 7.65  |
|  |  | 5     |      |             | 370   | 15   | 11.75 |
|  |  | 6     |      |             | 420   | 10   | 12.85 |
| 8  |  |       | 800  | bulk        | 29.40 |      |       |
| 10   |  |       | 1150 | bulk        | 56.25 |      |       |
| <b>Riser Clamp, Copper Tube Size Copper Plated</b><br><br><br><b>fig. 410</b>                                 |  | 1/2   |      |             | 60    | 25   | 4.20  |
|  |  | 3/4   |      |             | 60    | 25   | 4.20  |
|  |  | 1     |      |             | 65    | 25   | 4.33  |
|  |  | 1-1/4 |      |             | 72    | 25   | 5.05  |
|  |  | 1-1/2 |      |             | 74    | 25   | 5.38  |
|  |  | 2     |      |             | 105   | 25   | 6.43  |
|  |  | 2-1/2 |      |             | 168   | 25   | 8.40  |
|  |  | 3     |      |             | 178   | 25   | 10.50 |
|  |  | 4     |      |             | 205   | 25   | 13.13 |
|  |  | 5     |      |             | 346   | 20   | 28.75 |
| 6  |  |       | 386  | 10          | 32.15 |      |       |

# Split Ring Hangers

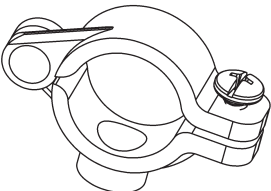
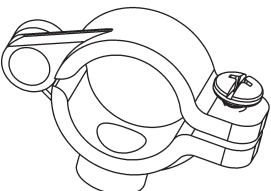
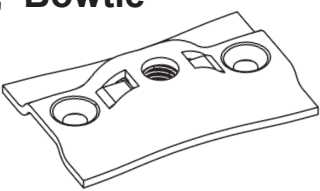
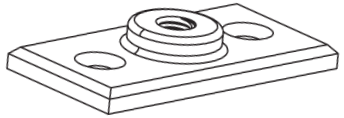
|  | Size<br>Inches | Weight<br>Per 100 | Quantity<br>Per Ctn | List Price Each |        |
|--|----------------|-------------------|---------------------|-----------------|--------|
|  |                |                   |                     | Plain           | Plated |
| <b>Split Ring, Iron Pipe Size<br/>Ductile Iron</b><br><br><br><br>3/8" to 2" - 3/8 Rod      Plain - <b>fig. 202</b><br>2-1/2" to 4" - 1/2 Rod      Zinc Plated - <b>fig. 385</b>          | 3/8            | 10                | 50                  | 1.84            | 2.10   |
|  | 1/2            | 10                | 50                  | 1.84            | 2.10   |
|  | 3/4            | 12                | 50                  | 1.97            | 2.17   |
|  | 1              | 14                | 50                  | 2.23            | 2.69   |
|  | 1-1/4          | 19                | 25                  | 2.69            | 3.02   |
|  | 1-1/2          | 21                | 25                  | 3.15            | 3.61   |
|  | 2              | 30                | 25                  | 3.61            | 4.33   |
|  | 2-1/2          | 43                | 25                  | 9.65            | 11.81  |
|  | 3              | 52                | 25                  | 12.40           | 14.44  |
|  | 4              | 67                | 25                  | 17.90           | 19.69  |
| <b>Split Ring, Copper Tube<br/>Ductile Iron</b><br><br><br><br>3/8" to 2" - 3/8 Rod <b>fig. 485</b><br>2-1/2" to 4" - 1/2 Rod   | 3/8            | 8                 | 50                  | 1.84            |        |
|  | 1/2            | 8                 | 50                  | 1.90            |        |
|  | 3/4            | 9                 | 50                  | 2.03            |        |
|  | 1              | 11                | 50                  | 2.30            |        |
|  | 1-1/4          | 12                | 25                  | 2.63            |        |
|  | 1-1/2          | 14                | 25                  | 3.15            |        |
|  | 2              | 23                | 25                  | 3.41            |        |
|  | 2-1/2          | 37                | 25                  | 10.50           |        |
|  | 3              | 45                | 25                  | 15.75           |        |
| 4  | 67             | 25                | 18.40               |                 |        |
| <b>Flange, Bowtie</b><br><br><br><br>Plain <b>fig. 208</b><br>Galvanized <b>fig. 389</b><br>Copperclad <b>fig. 489</b><br><br><b>Made in USA</b>  | 3/8            | 16.5              | 100                 | 1.38            |        |
|  | 3/8            | 16.5              | 100                 | 1.71            |        |
|  | 3/8            | 16.5              | 100                 | 1.84            |        |
| <b>Flange, Ductile Iron</b><br><br><br><br>Plain <b>fig. 820</b><br>Galvanized <b>fig. 821</b><br>Epoxy Coated <b>fig. 822</b><br><br><b>Import</b><br>Flanges Tapped for 3/8 & 1/2 Rod | 3/8            | 15                | 100                 | 1.38            |        |
|  | 1/2            | 16                | 100                 | 2.23            |        |
|  | 3/8            | 15                | 100                 | 1.71            |        |
|  | 1/2            | 16                | 100                 | 2.43            |        |
|  | 3/8            | 15                | 100                 | 1.84            |        |
|  | 1/2            | 16                | 100                 | 2.63            |        |

# Attachments

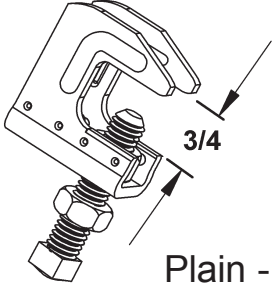
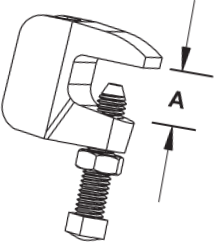
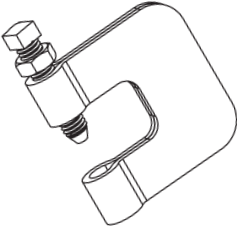
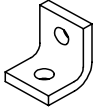
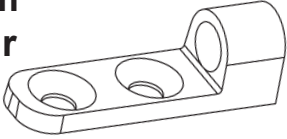
|   | Size<br>Inches | Weight<br>Per 100 | Quantity<br>Per Ctn | List Price Each |        |
|---|----------------|-------------------|---------------------|-----------------|--------|
|   |                |                   |                     | Plain           | Plated |
| <b>Top Beam Clamp</b><br><br>Steel<br>Made in USA<br>Patent # 8882056<br>Plain - <b>fig. 125</b><br>Plated - <b>fig. 325</b>   | 3/8            | 25                | 100                 | 1.90            | 2.75   |
| <b>Top Beam Clamp, Ductile Iron</b><br><br>Junior A = 3/4"<br>Plain - <b>fig. 825</b><br>Plated - <b>fig. 826</b><br>Wide Throat A = 1-1/4"<br>Import <b>fig. 126</b> | 3/8            | 28                | 100                 | 1.90            | 2.75   |
|   | 1/2            | 35                | 100                 | 2.63            | 4.20   |
|   | 5/8            | 42                | 50                  | 4.60            | 6.95   |
|   | 3/4            | 84                | 25                  | 7.35            | 10.50  |
|   | 3/8            | 36                | 50                  | 4.33            | ----   |
|   | 1/2            | 36                | 50                  | 5.25            | ----   |
| <b>"C" Clamps</b><br><br>W/O Locknut <b>fig. 122</b><br>W/ Locknut <b>fig. 123</b>   | 1/4            | 45                | 50                  | 2.31            | ----   |
|   | 3/8            | 40                | 100                 | 2.59            | ----   |
|   | 1/2            | 47                | 100                 | 2.82            | ----   |
|   | 3/8            | 41                | 100                 | 2.59            | ----   |
|   | 1/2            | 48                | 50                  | 3.18            | ----   |
|   | 5/8            | 75                | 50                  | 11.00           | ----   |
|   | 3/4            | 82                | 50                  | 13.20           | ----   |
|   | 3/8            | 25                | 100                 | 1.64            | ----   |
| <b>Angle Clip</b><br><br><b>fig. 118</b>   | 1/2            | 30                | 50                  | 2.04            | ----   |
|   | 3/8            | 13                | 100                 | 1.44            | ----   |
| <b>Side Beam Connector</b><br><br><b>fig. 191</b>  | 1/2            | 25                | 50                  | 2.43            | ----   |

# Strut Hardware

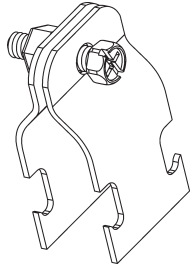
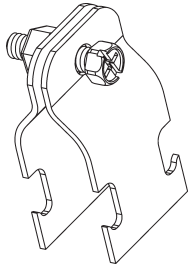
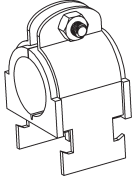
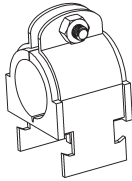
|   | Size<br>Inches | Weight<br>Per 100 | Quantity<br>Per Ctn | List Price<br>Each |
|---|----------------|-------------------|---------------------|--------------------|
| <b>Strut Clamp-IPS</b><br><b>Zinc Plated</b><br><br><b>fig. 311</b>  | 3/8            | 12                | 50                  | 1.31               |
|   | 1/2            | 13                | 50                  | 1.31               |
|   | 3/4            | 15                | 50                  | 1.60               |
|   | 1              | 18                | 50                  | 1.73               |
|   | 1-1/4          | 22                | 50                  | 2.10               |
|   | 1-1/2          | 32                | 50                  | 2.30               |
|   | 2              | 37                | 50                  | 2.43               |
|   | 2-1/2          | 42                | 25                  | 3.05               |
|   | 3              | 49                | 25                  | 3.45               |
|   | 4              | 70                | 25                  | 4.65               |
|   | 5              | 80                | 10                  | 5.75               |
|   | 6              | 90                | 10                  | 7.65               |
|   | 8              | 124               | 25                  | 11.75              |
| <b>Strut Clamp-CT</b><br><b>Copper Plated</b><br><br><b>fig. 411</b>   | 1/2            | 9                 | 50                  | 1.95               |
|   | 3/4            | 11                | 50                  | 2.10               |
|   | 1              | 15                | 50                  | 2.30               |
|   | 1-1/4          | 18                | 50                  | 2.40               |
|   | 1-1/2          | 22                | 50                  | 2.45               |
|   | 2              | 31                | 50                  | 3.15               |
|   | 2-1/2          | 35                | 25                  | 4.20               |
|   | 3              | 42                | 25                  | 4.60               |
|   | 4              | 60                | 25                  | 7.25               |
| <b>Cushion Clamp-IPS</b><br><b>Zinc Yellow</b><br><br>2-1/2" - 6" available<br>upon request<br><b>fig. 317</b> | 1/2            | 21                | 25/100              | 5.58               |
|   | 3/4            | 29                | 25/100              | 6.55               |
|   | 1              | 41                | 25/100              | 8.15               |
|   | 1-1/4          | 45                | 10/40               | 9.85               |
|   | 1-1/2          | 49                | 10/40               | 10.90              |
|   | 2              | 56                | 10/40               | 14.45              |
| <b>Cushion Clamp-CT</b><br><b>Zinc Yellow</b><br><br>2-1/2" - 4" available<br>upon request<br><b>fig. 417</b>  | 1/2            | 13                | 25/100              | 4.92               |
|   | 3/4            | 21                | 25/100              | 5.58               |
|   | 1              | 29                | 25/100              | 6.95               |
|   | 1-1/4          | 40                | 10/40               | 8.15               |
|   | 1-1/2          | 45                | 10/40               | 9.30               |
|   | 2              | 53                | 10/40               | 13.15              |



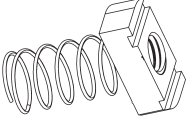
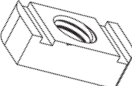
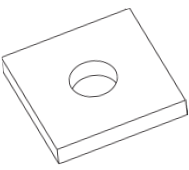
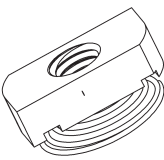
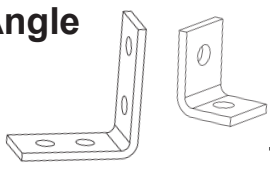
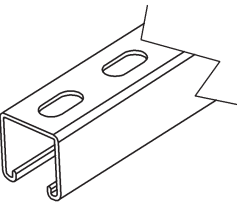

# Strut Hardware

|   | Size<br>Inches     | Weight<br>Per 100 | Quantity<br>Per Ctn | List Price<br>Each |       |
|---|--------------------|-------------------|---------------------|--------------------|-------|
| <b>Strut Nut, Spring</b><br><br><b>fig. 310</b>    | 3/8                | 10                | 100                 | 1.60               |       |
|   | 1/2                | 13                | 100                 | 1.70               |       |
| <b>Strut Nut, No Spring</b><br><br><b>fig. 315</b> | 3/8                | 9.4               | 100                 | 1.18               |       |
|   | 1/2                | 8.6               | 100                 | 1.31               |       |
| <b>Strut Washer</b><br><br><b>fig. 313</b>        | 3/8                | 18                | 100                 | 1.60               |       |
|   | 1/2                | 18                | 100                 | 1.60               |       |
|   | 1-5/8 SQ X 1/4 THK |                   |                     |                    |       |
| <b>Twirl Nut</b><br><br><b>fig. 309</b>          | 3/8                | 10                | 100                 | 1.75               |       |
| <b>Strut Angle</b><br><br><b>fig. 316</b>        | 2 hole             | 38                | 50                  | 2.63               |       |
|   | 4 hole             | 78                | 25                  | 5.25               |       |
| <b>10' Strut</b><br><br>Elongated holes          | <b>Galv</b>        | 1-5/8 - 12 GA     | 19.00 EA            | 50/bndl            | 95.00 |
|   | <b>fig. 930</b>    | 13/16 - 14 GA     | 9.50 EA             | 50/bndl            | 58.00 |
|   | <b>Green</b>       | 1-5/8 - 12 GA     | 19.00 EA            | 50/bndl            | 95.00 |
|   | <b>fig. 931</b>    | 13/16 - 14 GA     | 9.50 EA             | 50/bndl            | 58.50 |
|   | <b>Green</b>       | 1-5/8 - 14 GA     | 14.00 EA            | 50/bndl            | 77.00 |
| <b>fig. 932</b>   |                    |                   |                     |                    |       |

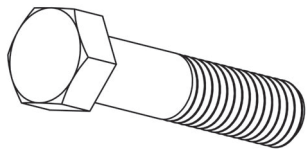
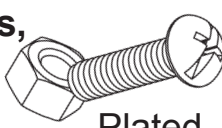
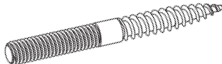
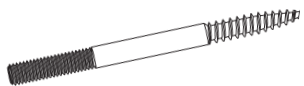
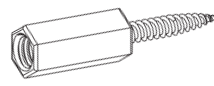
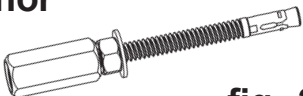
# Hardware

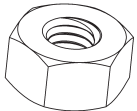

|  | Size<br>Inches | Weight<br>Per 100 | Quantity<br>Per Ctn | List Price Each |        |
|--|----------------|-------------------|---------------------|-----------------|--------|
|  |                |                   |                     | Plain           | Plated |
| <b>Hex Head Bolts<br/>ASTM A307a</b><br><br><br><br>Plain- <b>fig. 156</b><br>Plated- <b>fig. 356</b> | 5/8 X 2        | 23                | 50                  | 0.8855          | 1.2535 |
|  | 2-1/2          | 27                | 50                  | 1.0580          | 1.4835 |
|  | 3              | 32                | 50                  | 1.1960          | 1.6675 |
|  | 3-1/2          | 36                | 50                  | 1.3570          | 1.8975 |
|  | 4              | 40                | 50                  | 1.5065          | 2.1160 |
|  | 4-1/2          | 44                | 50                  | 1.8170          | 2.5875 |
|  | 5              | 49                | 50                  | 1.8975          | 2.6450 |
|  | 3/4 X 2        | 35                | 50                  | 1.4605          | 2.0585 |
|  | 2-1/2          | 41                | 50                  | 1.6330          | 2.3000 |
|  | 3              | 48                | 50                  | 1.9320          | 2.7025 |
|  | 3-1/2          | 54                | 50                  | 2.1160          | 2.9325 |
|  | 4              | 60                | 25                  | 2.4150          | 3.3925 |
|  | 4-1/2          | 66                | 25                  | 2.7025          | 3.7950 |
|  | 5              | 72                | 25                  | 2.9325          | 4.0825 |
| <b>Stove Bolts,<br/>With Nuts</b><br><br><br>Plated - <b>fig. 160</b>                               | 1/4 X 1        | 2.2               | 100                 | ----            | .15    |
|  | 1/4 X 1-1/2    | 3.1               | 100                 | ----            | .18    |
|  | 1/4 X 2        | 3.6               | 100                 | ----            | .23    |
| <b>Lag Screw</b><br><br><br><b>fig. 155</b>   | 1/4 X 3        | 3                 | 100                 | .76             | ---    |
|  | 3/8 X 3-1/2    | 8.5               | 100                 | .76             | ---    |
|  | 1/2 X 4        | 17                | 25                  | 2.30            | ---    |
| <b>Lag Rod</b><br><br><br><b>fig. 154</b>   | 3/8 X 4        | 10                | 100                 | .92             | ---    |
|  | 6              | 15                | 100                 | 1.12            | ---    |
|  | 8              | 19                | 50                  | 1.95            | ---    |
|  | 1/2 X 6        | 32                | 50                  | 2.90            | ---    |
| <b>Stanley Screw</b><br><br><br>for wood <b>fig. 358</b>  | 3/8            | 5.80              | 25/100              | ---             | 1.30   |
| <b>Elliott Anchor</b><br><br><br>for concrete <b>fig. 360</b>                                       | 1/4            | 8.30              | 25/100              | ---             | 1.85   |
|  | 3/8            | 15.50             | 25/100              | ---             | 1.85   |

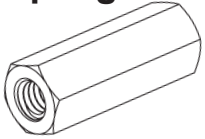
# Hardware

|   | Size<br>Inches | Weight<br>Per 100 | Quantity<br>Per Ctn | List Price Each |        |
|---|----------------|-------------------|---------------------|-----------------|--------|
|   |                |                   |                     | Plain           | Plated |
| <b>Hex Nuts<br/>Grade 2</b><br><br><br><br>Plain - <b>fig. 171</b><br>Plated - <b>fig. 371</b>       | 1/4            | .80               | 100                 | ----            | .105   |
|   | 5/16           | 1.10              | 100                 | ----            | .144   |
|   | 3/8            | 1.60              | 100                 | .10             | .16    |
|   | 1/2            | 3.80              | 100                 | .25             | .37    |
|   | 5/8            | 7.30              | 50                  | .43             | .65    |
|   | 3/4            | 11.90             | 50                  | .65             | .98    |
|   | 7/8            | 19                | 25                  | ----            | 2.10   |
|   | 1              | 28                | 25                  | ----            | 2.75   |
| <b>Heavy Hex Nuts<br/>Grade 2</b><br><br><br><br>Plain - <b>fig. 172</b><br>Plated - <b>fig. 372</b> | 3/8            | 3                 | 100                 | .17             | .24    |
|   | 1/2            | 7                 | 100                 | .32             | .46    |
|   | 5/8            | 12                | 50                  | .55             | .79    |
|   | 3/4            | 19                | 50                  | .85             | 1.18   |
| <b>Washers<br/>USS</b><br><br><br><br>Plain - <b>fig. 153</b><br>Plated - <b>fig. 353</b>          | 1/4            | .70               | 100                 | .053            | .087   |
|   | 3/8            | 1.5               | 100                 | .087            | .14    |
|   | 1/2            | 3.8               | 100                 | .21             | .30    |
|   | 5/8            | 7.7               | 50                  | .40             | .56    |
|   | 3/4            | 11.0              | 50                  | .46             | .68    |
|   | 7/8            | 15.3              | 50                  | .65             | 1.05   |
|   | 1              | 18.8              | 25                  | .92             | 1.30   |
| <b>Fender Washer</b><br><br><br><br>Plated - <b>fig. 253</b>                                       | 1/4 X 1.25     | 2.1               | 100                 | ----            | .18    |
|   | 3/8 X 1.5      | 2.9               | 100                 | ----            | .24    |
|   | 1/2 X 2.0      | 7                 | 100                 | ----            | .42    |
| <b>Rod Coupling</b><br><br><br><br>Plain- <b>fig. 151</b><br>Plated - <b>fig. 351</b>              | 1/4            | 2                 | 50                  | 1.18            | 1.57   |
|   | 3/8            | 11                | 50                  | 1.30            | 1.77   |
|   | 1/2            | 11                | 50                  | 1.45            | 2.65   |
|   | 5/8            | 18                | 50                  | 2.50            | 3.25   |
|   | 3/4            | 30                | 25                  | 3.95            | 5.25   |
| <b>Rod Coupling, Reducing</b><br><br><b>fig. 357</b>  | 3/8 - 1/4      | 4                 | 50                  | ----            | 2.10   |
|   | 1/2 - 3/8      | 7                 | 50                  | ----            | 2.75   |
|   | 5/8 - 1/2      | 14                | 50                  | ----            | 4.30   |

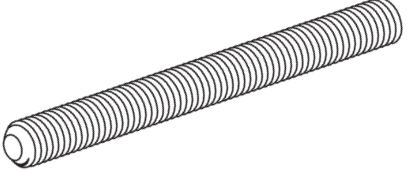

# Hardware & Tools

|  | Size<br>Inches | Weight<br>Each | Quantity<br>Per Ctn | List Price Each |        |
|--|----------------|----------------|---------------------|-----------------|--------|
|  |                |                |                     | Plain           | Plated |
| <b>All Thread Rod</b><br>6 Ft Length<br><br>Plain - <b>fig. 900</b><br>Plated - <b>fig. 901</b> | 1/4            | .72 ea         | 50                  | ----            | 3.75   |
|  | 3/8            | 1.7            | 25                  | 4.55            | 5.15   |
|  | 1/2            | 3.0            | 12                  | 9.90            | 10.65  |
|  | 5/8            | 5.0            | 8                   | 16.25           | 16.95  |
|  | 3/4            | 7.4            | 5                   | 23.75           | 27.82  |
|  | 7/8            | 10             | 4                   | ----            | 48.75  |
|  | 1              | 13             | 3                   | ----            | 68.75  |

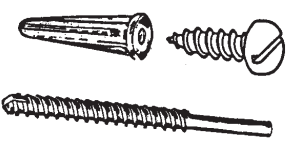

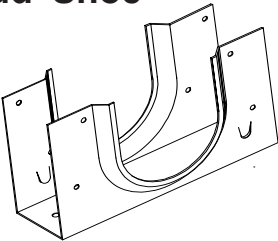
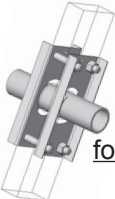

|   | Size  | Weight<br>Per 100 | Quantity<br>Per Ctn | List Price Each |
|---|-------|-------------------|---------------------|-----------------|
| <b>Stop Keys</b><br><br><b>fig. 413</b>   | 6 FT  | 750               | 6 / Bndl            | 62.00           |
|   | 8 FT  | 1000              | 6 / Bndl            | 75.80           |
|   | 10 FT | 1250              | 6 / Bndl            | 91.00           |
| <b>Grapplers</b><br><br><b>fig. 415</b>  | 6 FT  | 400               | 6 / Bndl            | 88.25           |
|   | 8 FT  | 600               | 6 / Bndl            | 103.50          |
|   | 10 FT | 800               | 6 / Bndl            | 120.00          |
| <b>Spoon Keys</b><br><br><b>fig. 414</b> | 6 FT  | 500               | 6 / Bndl            | 96.00           |

|   | Description   | Quantity<br>Per Ctn | List Price /Kit |
|---|---|---------------------|-----------------|
| <b>Screw and Plastic Anchor Kit</b><br><br><b>fig. 162</b> | 100-#10 x1" Pan Head Screws<br>100 - Plastic Anchors<br>1 each -1/4" Masonary Drill | 10                  | 11.25/Kit       |

# Stud Protectors

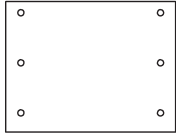
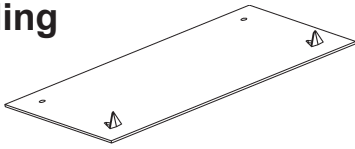
|  | Size     | Weight Per 100 | Quantity Per Ctn                   | List Price Each |
|--|----------|----------------|------------------------------------|-----------------|
| <b>16 Hole Plate - 5" wide</b><br><br><br><br><b>16 ga</b> <span style="float: right;"><b>fig. 950</b></span>   | 5 X 9    | 85             | 50                                 | 1.63            |
|  | 5 X 12   | 105            | 25                                 | 1.88            |
|  | 5 X 18   | 160            | 25                                 | 2.87            |
| <b>16 Hole Plate - 3" wide</b><br><br><br><br><b>16 ga</b> <span style="float: right;"><b>fig. 949</b></span>   | 3 X 12   | 52             | 25                                 | 1.31            |
|  | 3 X 18   | 96             | 25                                 | 1.81            |
|  | 3 X 24   | 120            | 25                                 | 2.63            |
|  | 3 X 36   | 190            | 25                                 | 5.25            |
| <b>16 Hole Plate - 1.5" wide</b><br><br><br><br><b>16 ga</b> <span style="float: right;"><b>fig. 948</b></span>   | 1.5 X 18 | 48             | 50                                 | 1.15            |
|  | 1.5 X 24 | 62             | 50                                 | 1.69            |
|  | 1.5 X 36 | 94             | 25                                 | 3.63            |
| <b>Stud Shoe</b><br><br><br><br>not for load bearing walls <span style="float: right;"><b>fig. 533-1</b></span><br><br><span style="float: right;"><b>fig. 533-2</b></span><br><br><span style="float: right;"><b>fig. 533-3</b></span> | Single   | 41             | 25                                 | 2.56            |
|  | Double   | 50             | 25                                 | 3.00            |
|  | Triple   | 60             | 10                                 | 3.56            |
| <b>Studfixer™</b><br><br><br>Kit includes Bolts, Nuts, Drill & Drill Fixture<br>1.5 DWV MAX<br>for load bearing walls<br><span style="float: right;"><b>fig. 534</b></span>   | Single   | 230            | 5 assy. / kit<br>Sold only as Kits | 11.81/ assy.    |
|  | Double   | 260            | 5 assy. / kit<br>Sold only as Kits | 12.38 / assy.   |
|  | Triple   | 290            | 5 assy. / kit<br>Sold only as Kits | 13.25 / assy.   |

# Stud Protectors

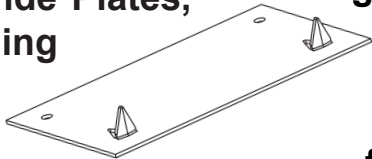
|   |  | Size     | Weight per 100 | Quantity Ctn / Skid | List Price Each |
|---|--|----------|----------------|---------------------|-----------------|
| <b>5" Wide Plates</b> <span style="float: right;"><b>16 ga x 5</b></span><br><br>* 18" has 4 holes<br><span style="float: right;"><b>fig 958</b></span>  |  | 5 X 4    | 35             | 50 / 5M             | .75             |
|   |  | 5 X 8    | 70             | 50 / 2500           | 1.40            |
|   |  | 5 X 18 * | 150            | 25 / 1500           | 2.63            |
| <b>5" Wide Plates, Self Nailing</b> <span style="float: right;"><b>16 ga x 5</b></span><br><br><span style="float: right;"><b>fig. 957</b></span>  |  | 5 X 4    | 35             | 25/2500             | .90             |
|   |  | 5 X 8    | 70             | 25 / 2500           | 1.50            |
| <b>1 1/2" Wide Plates, 8 Hole</b> <span style="float: right;"><b>18 ga x 1-1/2</b></span><br><span style="float: right;"><b>fig. 918</b></span><br><hr/> <span style="float: right;"><b>16 ga x 1-1/2</b></span><br><br><span style="float: right;"><b>fig. 916</b></span> |  | 9        | 18             | 50 / 5M             | .45             |
|   |  | 12       | 25             | 50 / 5M             | .56             |
|   |  | 18       | 38             | 50 / 3M             | .85             |
|   |  | 9        | 24             | 50 / 5M             | .55             |
|   |  | 12       | 32             | 50 / 5M             | .78             |
|   |  | 18       | 48             | 50 / 3M             | 1.15            |
| <b>3" Wide Plates, 8 Hole</b> <span style="float: right;"><b>18 ga x 3</b></span><br><br><span style="float: right;"><b>fig. 919</b></span>  |  | 6        | 25             | 50 / 6M             | .55             |
|   |  | 9        | 38             | 50 / 5M             | .83             |
|   |  | 12       | 52             | 50 / 5M             | 1.05            |
|   |  | 18       | 78             | 50 / 2400           | 1.63            |
| <b>3-1/2" Wide Plates</b> <span style="float: right;"><b>16 ga x 3</b></span><br><br>18" 4 Holes as shown, 6" 2 Holes<br><span style="float: right;"><b>fig. 935</b></span>  |  | 6        | 36             | 50 / 5M             | .66             |
|   |  | 18       | 110            | 25 / 1500           | 2.00            |
| <b>3-1/2" Wide Plates, Self Nailing</b> <span style="float: right;"><b>16 ga x 3.5</b></span><br><br><span style="float: right;"><b>fig. 936</b></span>  |  | 6        | 36             | 50/5M               | .79             |

# Stud Protectors

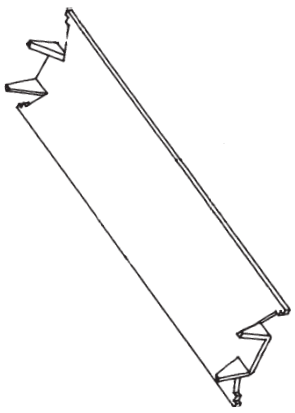
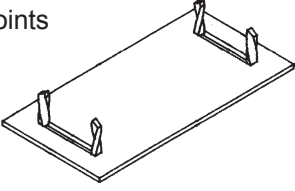
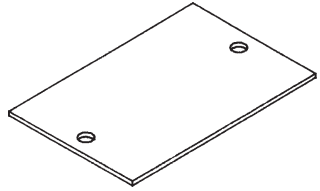
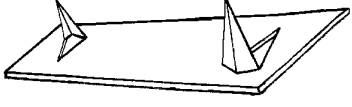
|  |                 | Length<br>Inches | Weight<br>Per 100 | Quantity<br>Ctn / Skid | List Price<br>Each |
|--|-----------------|------------------|-------------------|------------------------|--------------------|
| <b>Stud Guards</b><br>Triangle Points<br><br> | 18 ga x 1-1/2   | 3                | 6                 | 100 / 21M              | .163               |
|  |                 | 5                | 10                | 100 / 12M              | .206               |
|  | <b>fig. 530</b> | 6                | 13                | 100 / 12M              | .244               |
|  | 20 ga x 1-1/2   | 3                | 5                 | 100 / 21M              | .131               |
|  |                 | 6                | 10                | 100 / 12M              | .206               |
|  | <b>fig. 531</b> |                  |                   |                        |                    |
|  | 16 ga x 1-1/2   | 3                | 8                 | 100 / 21 M             | .206               |
|  |                 | 5                | 14                | 100 / 12M              | .275               |
|  | <b>fig. 536</b> | 6                | 16                | 100 / 12 M             | .325               |
| <b>Stud Guards</b><br>Twist Points<br><br>   | 19 ga x 1-1/2   | 3                | 6                 | 100 / 21M              | .156               |
|  |                 | 6                | 11                | 100 / 12M              | .238               |
| <b>Stud Guards</b><br>Nail Holes<br><br>    | 18 ga x 1-1/2   | 3                | 6                 | 250 / 30M              | .163               |
|  |                 | 6                | 13                | 100 / 12M              | .244               |
|  | <b>fig. 906</b> |                  |                   |                        |                    |
|  | 16 ga x 1-1/2   | 3                | 8                 | 250 / 30M              | .205               |
|  | 6               | 16               | 100 / 12M         | .325                   |                    |
| <b>fig. 905</b>  |                 |                  |                   |                        |                    |
| <b>Stud Guards</b><br>Interlocking<br><br>  | 20 ga x 1-1/2   | 20 GA            | 10                | 100 / 12M              | .206               |
|  | 18 ga x 1-1/2   |                  |                   |                        |                    |
|  | 16 ga x 1-1/2   | 18 GA            | 13                | 100 / 12M              | .244               |
| <b>fig. 922</b>  | 16 GA           | 16               | 100 / 12M         | .325                   |                    |



# INDEX

| PG. | FIG. | ITEM                     |                       | PG. | FIG. | ITEM                  |                           |
|-----|------|--------------------------|-----------------------|-----|------|-----------------------|---------------------------|
| 8   | 300  | Adj Swivel Rings         | Galvanized IPS        | 11  | 202  | Split Ring Hangers    | Ductile Iron, Plain       |
| 8   | 301  |                          | Copper Tube           | 11  | 385  |                       | Ductile Iron, Galv Pipe   |
| 6   | 302  |                          | Plastic Coated        | 11  | 485  |                       | Ductile Iron, Copper Tube |
| 17  | 900  | All Thread Rod           | Plain                 |     |      |                       |                           |
| 17  | 901  |                          | Plated                | 1   | 970  | Strapping             | Steel Plain               |
| 12  | 118  | Angle Clips              |                       | 1   | 972  |                       | Copperclad                |
| 8   | 430  | Bell Hangers             |                       | 1   | 971  |                       | Galvanized                |
|     |      |                          |                       | 7   | 102  |                       | Plastic                   |
| 12  | 122  | 'C' Clamps               | Plain                 | 1   | 974  |                       | Pure Copper               |
| 12  | 123  |                          | With Locknuts         | 1   | 975  |                       | Stainless Steel           |
|     |      |                          |                       | 1   | 101  |                       | Duct Tape, Galvanized     |
| 9   | 204  | Clevis Hangers           | Standard              | 4   | 620  | Strap, EMT            |                           |
| 9   | 304  |                          | Standard, Zinc Plated |     |      |                       |                           |
| 9   | 406  |                          | Copper Tube           | 4   | 600  | Straps, Pipe          | Galv Pipe, Two Hole       |
| 9   | 104  |                          | Light                 | 6   | 603  |                       | Galv Pipe, Plastic Coated |
| 6   | 404  |                          | Plastic Coated        | 4   | 760  |                       | Stainless, Pipe Two Hole  |
|     |      |                          |                       | 4   | 610  |                       | Galv Pipe, One Hole       |
| 5   | 220  | DWV Hangers              | Plastic Coated        |     |      |                       |                           |
| 5   | 320  |                          | L.W. Plastic Coated   | 3   | 500  | Straps, Tube          | Copperclad, Two Hole      |
| 5   | 120  |                          | Galvanized (Uncoated) | 3   | 510  |                       | Copperclad, One Hole      |
| 5   | 221  |                          | DWV Extensions        | 3   | 503  |                       | Pure Copper, Two Hole     |
|     |      |                          |                       | 3   | 509  |                       | Nails                     |
| 11  | 208  | Flanges                  | Bowtie, Plain         |     |      |                       |                           |
| 11  | 389  |                          | Bowtie, Galv          | 14  | 930  | Strut                 | Galv                      |
| 11  | 489  |                          | Bowtie, CClad         | 14  | 931  |                       | Green                     |
| 11  | 820  |                          | Ductile Iron, Plain   | 13  | 411  | Strut Clamps          | Copper Tube               |
| 11  | 821  |                          | Ductile Iron, Galv    | 13  | 311  |                       | Galv IPS                  |
| 11  | 822  |                          | Ductile Iron, Epoxy   | 13  | 317  | Strut Cushion Clamp   | IPS                       |
|     |      |                          |                       | 13  | 417  |                       | Copper                    |
| 15  | 156  | Hex Head Bolts           | Plain                 | 14  | 316  | Strut                 | Angle                     |
| 15  | 356  |                          | Plated                | 14  | 310  |                       | Nuts                      |
| 16  | 171  | Hex Nuts                 | Plain                 | 14  | 313  |                       | Washers                   |
| 16  | 371  |                          | Plated                |     |      |                       |                           |
| 16  | 172  |                          | Heavy, Plain          | 19  | 957  | Stud Protector Plates | 16 Ga 5x8 Self Nailing    |
| 16  | 372  |                          | Heavy, Plated         | 19  | 958  |                       | 16 Ga 5" Wide             |
|     |      |                          |                       | 18  | 950  |                       | 16 Ga 16 Hole 5" Wide     |
| 2   | 197  | Hooks                    | Bright Steel          | 18  | 949  |                       | 16 Ga 16 Hole 3" Wide     |
| 2   | 198  |                          | Copper Tube           | 18  | 948  |                       | 16 Ga 16 Hole 1.5" Wide   |
| 2   | 199  |                          | Plastic Coated        | 19  | 936  |                       | 16 Ga 3.5" Self Nailing   |
|     |      |                          |                       | 19  | 935  |                       | 16 Ga 3.5" Wide           |
| 6   | 113  | J Hanger                 | Plastic Coated        | 19  | 919  |                       | 18 Ga 8 Hole, 3" Wide     |
| 3   | 540  | J-Tube Nailer            | Copper Tube           | 19  | 918  |                       | 18 Ga 8 Hole, 1.5" Wide   |
| 15  | 154  | Lag Rod                  |                       | 19  | 916  |                       | 16 Ga 8 Hole, 1.5" Wide   |
| 15  | 155  | Lag Screw                |                       |     |      |                       |                           |
|     |      |                          |                       | 20  | 906  | Stud Guards           | Nail Holes 18 Ga          |
| 7   | 511  | Plastic Half Clamp       |                       | 20  | 905  |                       | Nail Holes 16 Ga          |
| 7   | 515  | Plastic Suspension Clamp |                       | 20  | 922  |                       | Interlocking 20 Ga        |
| 7   | 517  | Plastic Tube Clamp       |                       | 20  | 536  |                       | Triangle Points 16 Ga     |
|     |      |                          |                       | 20  | 530  |                       | Triangle Points 18 Ga     |
| 17  | 415  | Plumbers' Tools          | Grapplers             | 20  | 531  |                       | Triangle Points 20 Ga     |
| 17  | 414  |                          | Spoon Keys            | 20  | 920  |                       | Twisted Points 19 Ga      |
| 17  | 413  |                          | Stop Keys             |     |      |                       |                           |
|     |      |                          |                       | 18  | 534  | Stud Fixer            |                           |
| 10  | 108  | Riser Clamps             | Iron Pipe             | 18  | 533  | Stud Shoes            |                           |
| 10  | 410  |                          | Copper Tube           | 15  | 160  | Stove Bolts With Nuts |                           |
| 6   | 107  |                          | Plastic Coated        |     |      |                       |                           |
|     |      |                          |                       | 12  | 125  | Top Beam Clamps       | Plain                     |
| 16  | 151  | Rod Couplings            | Plain                 | 12  | 325  |                       | Plated                    |
| 16  | 351  |                          | Plated                | 12  | 126  |                       | Wide Throat               |
| 16  | 357  |                          | Reducing, Plated      |     |      |                       |                           |
|     |      |                          |                       | 16  | 153  | Washer                | Plain                     |
| 10  | 105  | Shields                  | Insulation            | 16  | 353  |                       | Plated                    |
| 12  | 191  | Side Beam Connectors     |                       | 16  | 253  |                       | Fender                    |
|     |      |                          |                       |     |      |                       |                           |
| 7   | 513  | Single Shot Hanger       |                       |     |      |                       |                           |