

## Improving Indoor Air Quality Through Better Ventilation

 Product Lines: 

- [Inline Duct Fans](#)
- [Dryer Booster Fans](#)
- [Exterior Fans](#)
- [Exhaust Fans](#)
- [Axial Fans](#)
- [Radon Fans](#)
- [Whole House HEPA Filtration](#)
- [Heat Recovery Ventilators](#)
- [Energy Recovery Ventilators](#)
- [Air Curains](#)
- [Grilles & Dampers](#)
- [Accessories](#)

### FR Series Fans

- [Product Brochure in PDF](#) (436 kb)
- [Submittal Specifications in PDF](#) (83 kb)
- [Guide Specifications in PDF](#) (27 kb)
- [Inlet and Exhaust Accessories](#)
- [Installation instructions in PDF](#) (561 kb)
- [Literature Request](#)
- [Warranty](#)

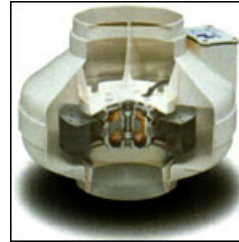

If you do not have Adobe Acrobat Reader, [click here](#).

### Inline Centrifugal Fans for Round Duct

*the ultimate in quality, quiet performance and cost efficiency*



#### Easy to install. Loaded with features.

- Prewired and supplied with a mounting bracket for easy installation
- Available singularly with bracket or in a variety of kits for specific applications. Each kit includes the appropriate fan and accessories
- Tested and approved by UL and CSA (or equals)
- Approved for residential and commercial applications and for wet locations
- Suitable for airstream temperatures up to 140° F
- Easy connection using external wiring box with waterproof gasket
- 122-649 CFM
- 4" to 10" duct diameters
- 100% speed controllable
- Five-year factory warranty

Kits are available for the following applications:

- Dryer Boosting Kit (DBF 110) for boosting clothes dryer installations with extended duct runs
- Regular Kits (REG 100 and REG 140) for single point exhaust applications
- Deluxe Kits (DLX 110, DLX 150, and DLX 200) designed for dual point exhaust applications
- Vent Light Kits (REG 100L, DLX 150L) for single and dual vent light exhaust applications

#### Versatility and Value

Fantech's versatile FR Series fans feature a plastic housing constructed of UL-recognized, UV-protected thermoplastic resin. This tough protective shell allows the fan to be mounted in outdoor and wet locations.\* Ideal for multiple point exhaust, dual bathroom exhaust, or new room additions, Fantech's FR Series fans are caulked at the motor screws, the wiring cables and along the seams of the fan to prevent moisture from entering the housing. Fantech's FR Series fans have long been the choice of residential builders and remodelers but now can be used for commercial projects with our recent UL commercial applications rating.

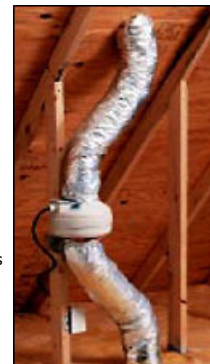

# FR SERIES

## INLINE EXHAUST FANS



### DIMENSIONAL DATA

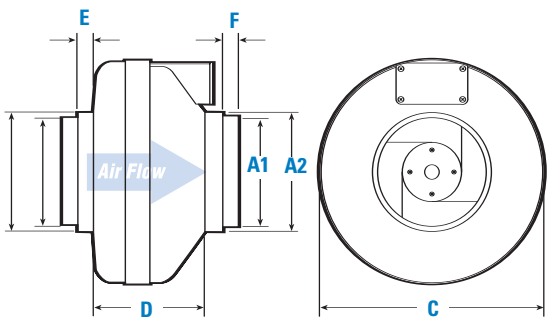

Model	†A1	A2	C	D	E	F
FR 100	4	5	9½	6⅞	7⅞	7⅞
FR 110	4	5	9½	6⅞	7⅞	7⅞
FR 125	—	5	9½	6⅞	7⅞	—
FR 140	6	6¼	11¾	5⅞	1	7⅞
FR 150	6	6¼	11¾	5⅞	1	7⅞
FR 160	6	6¼	11¾	5⅞	1	7⅞
FR 200	8	10	13¼	6¼	1½	1½
FR 225	8	10	13¼	6¼	1½	1½
FR 250	—	10	13¼	6¼	1½	—

All dimensions in inches.  
 † Duct connections are 1/8" smaller than duct size.

**FIVE  
YEAR  
WARRANTY**



Look for the Energy Star Rated Models in Performance Data Chart.

### AIR PERFORMANCE GRAPHS

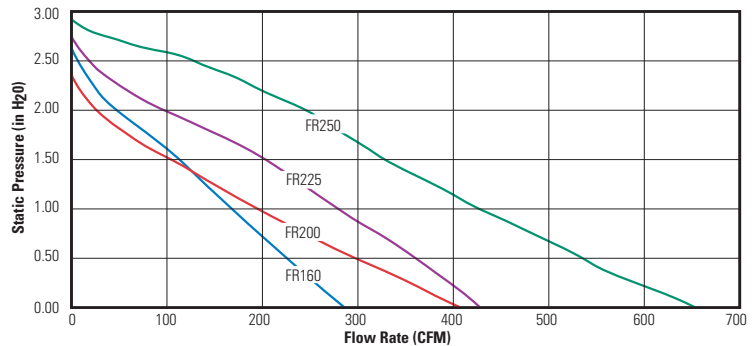
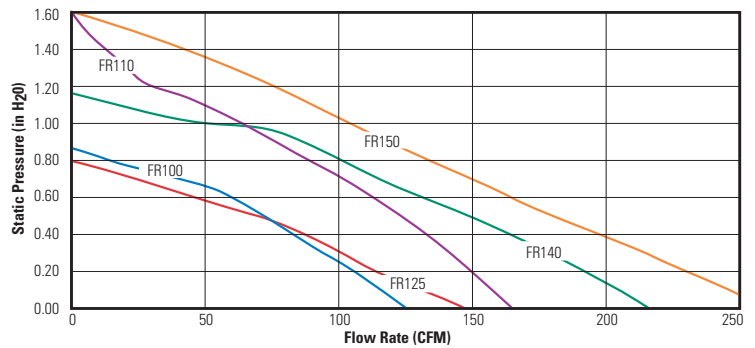

### PERFORMANCE DATA

Fan Model	Energy Star	RPM	Voltage	Rated Watts	Wattage Range	Max. Amps	Static Pressure in Inches W.G.						Max. Ps	Duct Dia.	
							0"	.2"	.4"	.6"	.8"	1.0"			1.5"
FR 100	✓	2900	115	19	13 – 19	0.18	122	100	78	55	15	—	—	0.87"	4"
FR 110	—	2900	115	80	62 – 80	0.72	167	150	133	113	88	63	4	1.60"	4"
FR 125	✓	2950	115	18	15 – 18	0.18	148	120	88	47	—	—	—	0.79"	5"
FR 140	✓	2850	115	61	47 – 62	0.53	214	190	162	132	99	46	—	1.15"	6"
FR 150	✓	2750	120	71	54 – 72	0.67	263	230	198	167	136	106	17	1.58"	6"
FR 160	—	2750	115	129	103 – 130	1.14	289	260	233	206	179	154	89	2.32"	6"
FR 200	✓	2750	115	122	106 – 128	1.11	408	360	308	259	213	173	72	2.14"	8"
FR 225	✓	3100	115	137	111 – 152	1.35	429	400	366	332	297	260	168	2.48"	8"
FR 250	—	2850	115	241	146 – 248	2.40	649	600	553	506	454	403	294	2.58"	10"

Performance shown is for installation type D - Ducted inlet, Ducted outlet. Speed (RPM) shown is nominal. Performance is based on actual speed of test. Performance ratings do not include the effects of appurtenances in the airstream.



**United States** 1712 Northgate Blvd. • Sarasota, FL. 34234 • 1.800.747.1762 • www.fantech.net  
**Canada** 50 Kanalfakt Way • Bouctouche, NB E4S 3M5 • 1.800.565.3548 • www.fantech.ca

Item #: 450399  
 Rev Date: 022508

Fantech, reserves the right to modify, at any time and without notice, any or all of its products' features, designs, components and specifications to maintain their technological leadership position.