

Installation Instructions

Part No: CRECOMZR076A00, CRECOMZR078A00 and CRECOMZR080A00

CONTENTS

SAFETY CONSIDERATIONS	1
GENERAL	2
ACCESSORIES AND COMPLIANCE	3
Accessories List	3
Compliance	3
INSTALLATION	3
Installation Instructions for 48/50LC 07-12 Units ONLY	9
Installing Optional HH57AC081 Single Outside Air Enthalpy Sensor	10
Installing Differential Return Air Sensor	12
California's Title 24 High Temperature Limit Settings	13
Demand Controlled Ventilation	13
Remote (Downstairs) Monitoring of Controller's Fault Detection and Diagnostics	13
GENERAL W7220 CONTROLLER AND SENSOR INFORMATION	14
W7220 Economizer	14
User Interface	14
Keypad	14
Using the Keypad with Menus	14
Using the Keypad with Settings and Parameters ..	14
Programming the W2770 Controller	15
• SETPOINTS	
• SYSTEM SETUP	
Menu Structure	15
Checkout Tests	20
W7220 Economizer Module Wiring	20
• TIME-OUT AND SCREEN SAVER	
START-UP AND OPERATION	20
Cooling with EconoMi\$er® X	20
Heating with EconoMi\$er® X	21
TROUBLESHOOTING	21
Power Loss (Outage or Brownout)	21
Alarms	21
• CLEARING ALARMS	

SAFETY CONSIDERATIONS

Installation and servicing of air-conditioning equipment can be hazardous due to system pressure and electrical components. Only trained and qualified service personnel should install, repair, or service air-conditioning equipment.

Untrained personnel can perform basic maintenance functions of cleaning coils and filters and replacing filters. All other operations should be performed by trained service personnel.

When working on air-conditioning equipment, observe precautions in the literature, tags and labels attached to the unit, and other safety precautions that may apply.

Follow all safety codes, including ANSI (American National Standards Institute) Z223.1. Wear safety glasses and work gloves. Use quenching cloth for unbrazing operations. Have fire extinguisher available for all brazing operations.

It is important to recognize safety information. This is the safety-alert symbol . When you see this symbol on the unit and in instructions or manuals, be alert to the potential for personal injury.

Understand the signal words DANGER, WARNING, CAUTION, and NOTE. These words are used with the safety-alert symbol. DANGER identifies the most serious hazards which **will** result in severe personal injury or death. WARNING signifies hazards which **could** result in personal injury or death. CAUTION is used to identify unsafe practices, which **may** result in minor personal injury or product and property damage. NOTE is used to highlight suggestions which **will** result in enhanced installation, reliability, or operation.

 WARNING
<p>ELECTRICAL SHOCK HAZARD</p> <p>Failure to follow this warning could cause personal injury or death.</p> <p>Before performing service or maintenance operations on unit, turn off main power switch to unit and install lock(s) and lockout tag(s). Ensure electrical service to rooftop unit agrees with voltage and amperage listed on the unit rating plate. Unit may have more than one power switch.</p>

 CAUTION
<p>CUT HAZARD</p> <p>Failure to follow this caution may result in personal injury.</p> <p>Sheet metal parts may have sharp edges or burrs. Use care and wear appropriate protective clothing, safety glasses and gloves when handling parts and servicing air conditioning equipment.</p>

 CAUTION
<p>PERSONAL INJURY HAZARD</p> <p>Failure to follow this caution can result in personal injury and damage to the unit.</p> <p>Cover the duct opening as a precaution so objects cannot fall into the return duct opening. Be sure to remove the cover when installation is complete.</p>

GENERAL

The EconoMiSer® X system utilizes the latest technology available for integrating the use of free cooling with mechanical cooling for packaged rooftop units. The code compliant W7220 control system optimizes energy consumption, zone comfort, and equipment cycling by operating the compressors when the outdoor-air temperature is too warm, integrating the compressor with outdoor air when free cooling is available, and locking out the compressor when outdoor-air temperature is too cold. Demand controlled ventilation is supported.

This EconoMiSer X system can be used with 1 or 2 speed indoor fan motor units. (All other speed settings listed are for future use.)

The EconoMiSer X system utilizes gear-drive technology with a direct-mount spring return actuator that will close upon loss of power. The EconoMiSer X system comes standard with fault detection and diagnostics (FDD), an outdoor air temperature sensor, and mixed air temperature sensor (also called supply air temperature sensor). Outdoor enthalpy, indoor (return) dry bulb or enthalpy, and CO₂ sensors are available for field installation.

Standard integrated barometric relief dampers provide natural building pressurization control. An optional power exhaust system is available for applications requiring even greater exhaust capabilities. The power exhaust set point is adjustable at the EconoMiSer X controller.

See Table 1-3 for package usage. See Table 4 for package contents. See Table 5 for sensor usage.

IMPORTANT: Read these instructions completely before attempting to install accessory economizer.

Table 1 — Carrier Usage Chart

CARRIER MODEL NUMBER	ECONOMISER® X PART NUMBER
Small Cabinet	
48/50HC, LC 04-06	CRECOMZR076A00
48/50TC 04-07	
50TCQ 04-07	
50HCQ 04-06	
50KCQ04-06	
48/50KC 04-06	
Large Cabinet	
48/050HC 07-12	CRECOMZR078A00
48/50LC 07	
48/50TC 08-14	
50TCQ 08-12	
50HCQ 07-09	
Extra Large Cabinet	
48/50HC 14	CRECOMZR080A00
48/50LC 08-12	
48/50TC 16	
50TCQ 14	
50HCQ 12	

Table 2 — Bryant Usage Chart

BRYANT MODEL NUMBER	ECONOMISER X PART NUMBER
Small Cabinet	
581J/551J 04-06	CRECOMZR076A00
549J/547J/559J/582J 04-06	
548J/580J/558J 04-07	
Large Cabinet	
581J/551J 07-12	CRECOMZR078A00
580J/558J 08-14	
548J 08-12	
549J 07-09	
Extra Large Cabinet	
581J/551J 14	CRECOMZR080A00
580J/558J 16	
548J 14	
549J 12	

Table 3 — ICP Usage Chart

ICP MODEL NUMBER	ECONOMISER X PART NUMBER
Small Cabinet	
RGH/RAH 036-060	CRECOMZR076A00
RGS/RAS 036-072	
RHS 036-072	
RHX/RHH 036-060	
RGX/RAX 036-060	
Large Cabinet	
RGH/RAH 072-120	CRECOMZR078A00
RAS/RGS 090-150	
RHH 072-102	
RHS 090-120	
Extra Large Cabinet	
RGH/RAH 150	CRECOMZR080A00
RAS/RGS 180	
RHS 150	
RHH 120	

Table 4 — Package Contents

ECONOMIZER PART NUMBER	QTY	CONTENTS
CRECOMZR076A00, CRECOMZR078A00	1	EconoMiSer Damper Assembly with Actuator and HH79AH001 (HW: C7250) Outside Air Sensor
	1	HW63AW002 (HW: W7220) Controller with Attached Harness*
	1	HH79ZZ007 Mixed Air Temp Sensor*
	1	48TMHSRSE--A20 4-Wire Harness*
	1	Hood Assembly with Top and 2 Sides
	1	Hood Divider
	1	Aluminum Filter
	1	Hardware Bag*
CRECOMZR080A00	1	EconoMiSer Damper Assembly with Actuator and HH79AH001 (HW: C7250) Outside Air Sensor
	1	HW63AW002 (HW: W7220) Controller with Attached Harness*
	1	HH79ZZ007 Mixed Air Temp Sensor*
	1	48TMHSRSE--A20 4-Wire Harness*
	1	Hood Assembly with Top and 2 Sides
	1	Hood Divider
	1	Hood Filter Divider
	2	Aluminum Filter
1	Hardware Bag*	

* Shipped in hardware kit for field installation.
HW = Honeywell

Table 5 — EconoMi\$er X Sensor Usage

APPLICATION	ECONOMISER X WITH OUTDOOR AIR DRY BULB SENSOR		
	Accessories Required		
Outdoor Air Dry Bulb	The HH79ZZ007 outdoor air dry bulb sensor is factory installed on economizer.		
Mixed Air Sensor	HH79ZZ007 provided with economizer and field installed in blower compartment.		
Single Enthalpy	HH57AC081		
Differential Dry Bulb or Enthalpy	CRDIFRASN01A00*** (When available, or MicroMetl part number 9901-2022-DIFF JC2)		
CO ₂ for DCV Control using a Wall-Mounted CO ₂ Sensor	33ZCSENCO2 or CGCDXSEN004A00		
CO ₂ for DCV Control using a Duct-Mounted CO ₂ Sensor	33ZCSENCO2 or CGCDXSEN004A00* and 33ZCSENCO2 or CGCDXASP00100†	OR	CRCBDIOX005A00**

* Accessory CO₂ sensors.

† Accessory aspirator boxes required for duct-mounted applications.

** CRCBDIOX005A00 is an accessory that contains both 33ZCSENCO2 and 33ZCASPCO2 accessories.

*** Includes HH57AC081 sensor and wiring harness.

ACCESSORIES AND COMPLIANCE

Accessories List

The EconoMi\$er X system has several field-installed accessories available to optimize performance. Refer to Table 6 for authorized parts and power exhaust descriptions.

Table 6 — EconoMi\$er® X Field-Installed Accessories

DESCRIPTION	PART NUMBER
208/230v 1PH Power Exhaust for Small Cabinet	CRPWREXH030A01
460v 3PH Power Exhaust for Small Cabinet	CRPWREXH021A01
208/230v 1PH Power Exhaust for Large Cabinet	CRPWREXH022A01
460v 3PH Power Exhaust for Large Cabinet	CRPWREXH023A01
208/230v 1PH Power Exhaust for Extra Large Cabinet	CRPWREXH080A00
460v 3PH Power Exhaust for Extra Large Cabinet	CRPWREXH081A01
Enthalpy Sensor (OA)	HH57AC081
Differential (Return) Sensor	CRDIFRASN01A00*
CO ₂ Sensor and Aspirator Box	CRCBDIOX005A00
Return Air CO ₂ Sensor (4 to 20 mA)	CRCBDIOX002A00
CO ₂ Room Sensor (4 to 20 mA)	33ZCSENCO2 or CGCDXSEN004A00
Aspirator Box for Duct Mount CO ₂ Sensor (4 to 20 mA)	33ZCASPCO2 or CGCDXASP001A00
Economizer Angle Seal Kit for use with unit's with Hinged Filter Door - for Small Cabinet	CRPECONV003A00
Economizer Angle Seal Kit for use with unit's with Hinged Filter Door - for Large Cabinet	CRPECONV004A00
Economizer Angle Seal Kit for use with unit's with Hinged Filter Door - for Extra Large Cabinet	CRPECONV007B00

* When available, or order MicroMetl PN 9901-2022-DIFF JC2.

Compliance

Economizers meet California Energy Commission Title 24 mandatory section 120.2.i for Fault Detection and Diagnostic controls.

Economizers meet ASHRAE 90.1 Fault Detection and Diagnostic requirements.

Economizers meet IECC Fault Detection and Diagnostic requirements.

NOTE: IECC requires differential return air sensor, which must be ordered separately. See Accessory CRDIFRASN01A00.

INSTALLATION

See Fig. 1 for component locations.

NOTE: If installing economizer on 48/50LC 07-12 units, see special section beginning on page 9.

1. Turn off power supply(s) and install lockout tag.
2. Remove the existing unit filter access panel. Raise the panel and swing the bottom outward. The panel is now disengaged from the track and can be removed. See Fig. 2. Set the filter door aside for re-installation later.
3. Remove the indoor coil access panel and discard. See Fig. 2.
4. Slide the EconoMi\$er X assembly into the rooftop unit. See Fig. 3.

NOTE: On small and large cabinets, be sure to engage the rear EconoMi\$er X flange under the tabs on the unit base in the return air chamber. See Fig. 4.

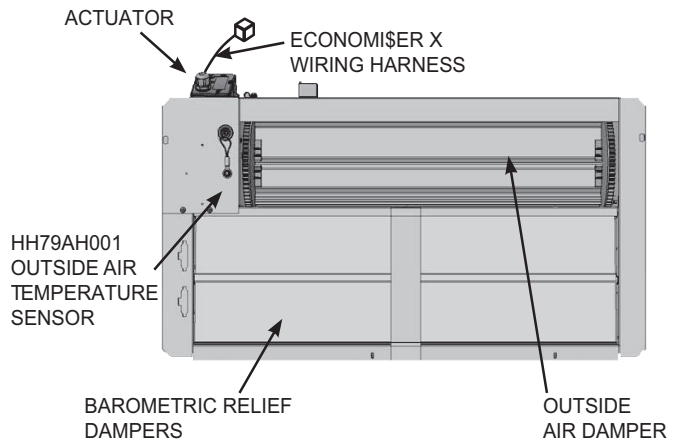

Fig. 1 — EconoMi\$er X Component Locations (CRECOMZR076A00 Shown)

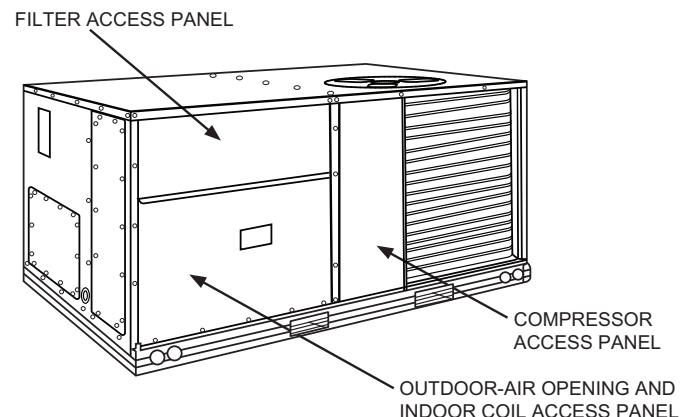

Fig. 2 — Typical Access Panel Locations

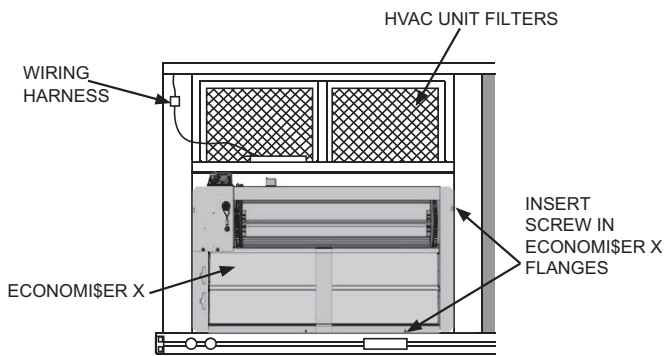

Fig. 3 — EconoMiSer® X Installed on HVAC Unit (CRECOMZR076A00 Shown)

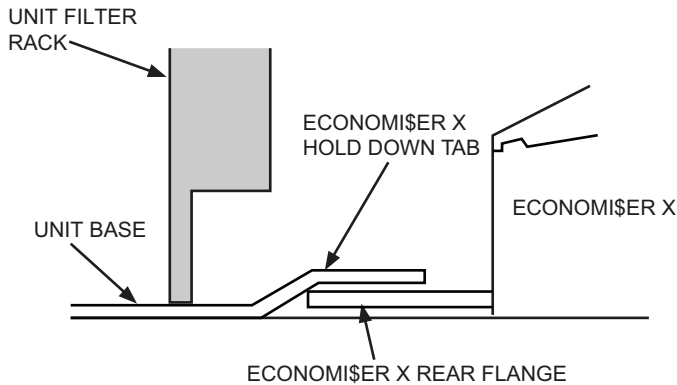

Fig. 4 — Rear EconoMiSer X Flange Installation (CRECOMZR076A00 and CRECOMZR078A00)

5. Ensure EconoMiSer X assembly is square. Screw the EconoMiSer X system to the unit along both side flanges and bottom flange. See Fig. 3.
6. Remove the red tape securing the relief dampers for shipping purposes.
7. If the EconoMiSer X system will be operating with an enthalpy outside air sensor, remove the factory installed HH79ZZ007 dry bulb sensor from the front face of the economizer (see Fig. 1), and install the accessory enthalpy sensor HH57AC081 in the same location. Connect the (2) wire gray harness with plug from the EconoMiSer X assembly to the enthalpy sensor. See wiring diagram Fig. 23 and 28. Refer to “Installing Optional HH57AC081 Outside Air Enthalpy Sensor” section for more details on enthalpy settings.

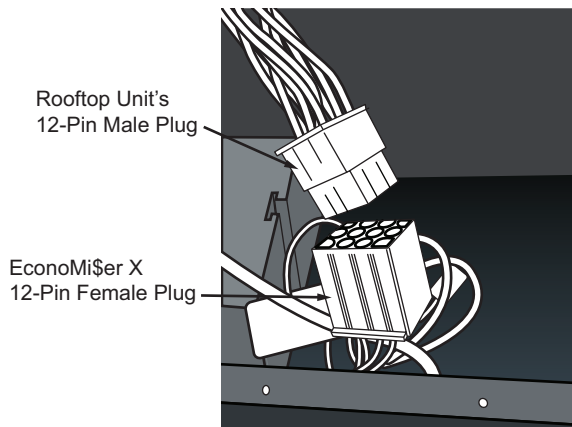

Fig. 5 — Connect EconoMiSer X Harness to Unit PL6 Economizer Harness

8. Remove and save the 12-pin jumper plug from the unit economizer harness – located in the upper left corner of the unit. Insert the EconoMiSer X plug into the unit wiring harness. See Fig. 5.

NOTE: The 12-pin jumper plug should be saved for future use, in the event that the EconoMiSer X assembly is ever removed. The jumper plug is not needed as long as the EconoMiSer X is installed.

9. Remove the indoor blower access panel and the panel(s) covering the unit control box. See Fig. 6.

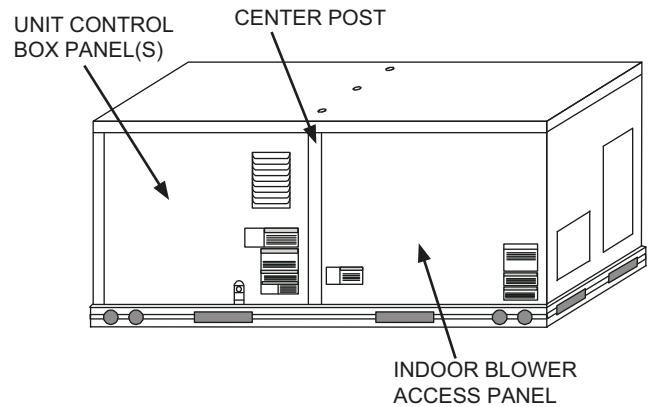
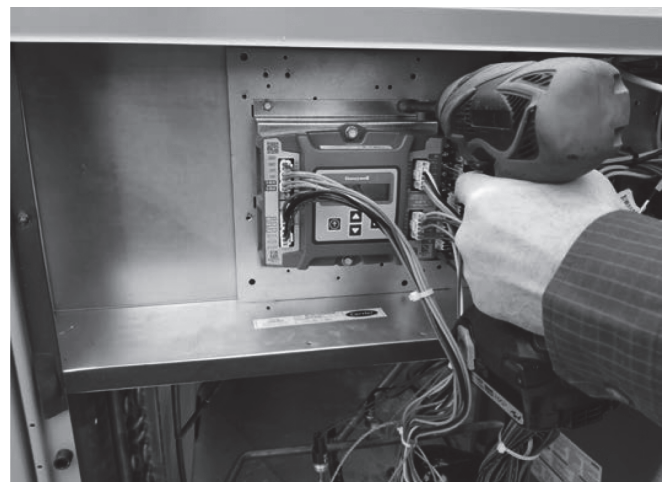

Fig. 6 — Typical Indoor Fan Motor Access Panel Locations

10. In the hardware kit provided with the EconoMiSer X is the HH63AW002 controller (Honeywell W7220). The controller is attached to a mounting bracket and the EconoMiSer X harness is attached to the controller. Mount the controller assembly on the left side of the unit control box. Screw bracket to the control box through pre-punched holes in control box. See Fig. 7.



NOTE: Some control box configurations may differ.

Fig. 7 — Mount Controller Assembly in Unit Control Box

11. Unplug the 10-pin female ECON plug currently connected to the Central Terminal Board (CTB). See Fig. 8.

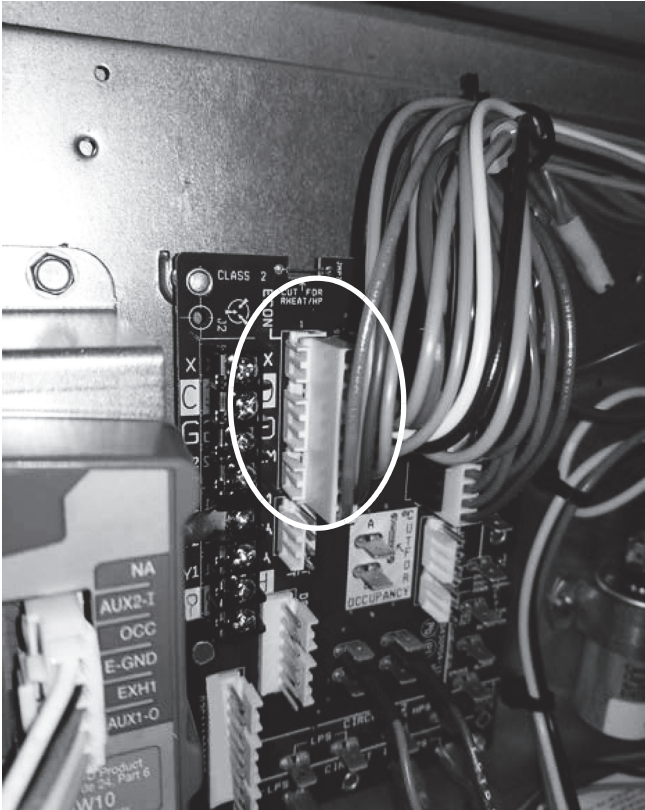

Fig. 8 — Unplug ECON plug from Central Terminal Board (CTB)

12. Connect the 10-pin female ECON plug removed from the CTB to the 10-pin male plug from the controller harness. See Fig. 9 and 23.

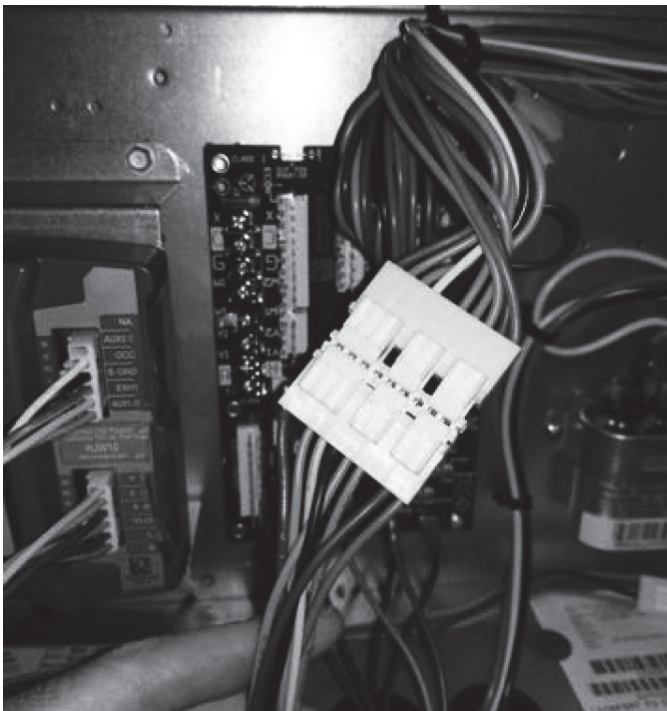

Fig. 9 — Connect 10-pin Plugs Together

13. Connect the 10-pin female plug from the controller harness to ECON on the CTB. See Fig. 10 and 23.

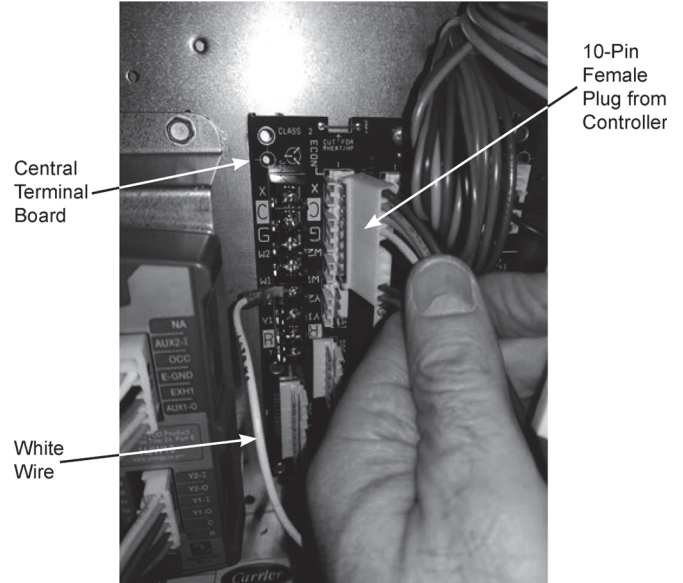

Fig. 10 — Connect 10-Pin Plug to Central Terminal Board

14. Connect the White wire from the controller harness to the W1 terminal on the CTB. See Fig. 10 and 23.
15. Connect the red and brown wires from the controller harness to the CTB. See Fig. 11 and 23. The red wire connects to “R” on the CTB, and the brown wire connects to “C”.

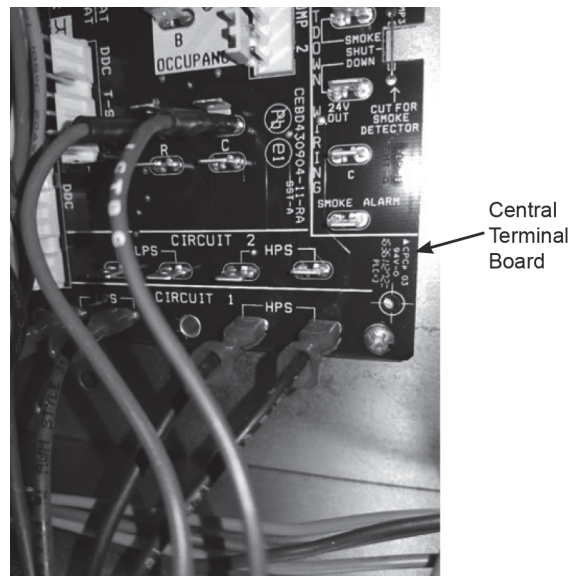

Fig. 11 — Connect Red and Brown Wires to Central Terminal Board

16. Locate the green wire with yellow stripe from the controller harness and screw it to the control box (ground). See Fig. 12.



Fig. 12 — Connect Ground Wire From Controller

17. Locate the 48TMHSRSE--A20 harness (with 4-pin female plug) provided in the hardware kit with the EconoMi\$er X. Connect the 48TMHSRSE--A20 harness to the 4-wire harness with a male plug from the controller harness. See Fig. 13 and 23.

4-Pin Male Plug from Controller 48TMHSRSE--A20 Harness



Fig. 13 — Connect 48TMHSRSE--A20 Harness to Harness from Controller

18. Route the 4-wire 48TMHSRSE--A20 harness through the divider between the control box and the indoor blower section. See Fig. 14.

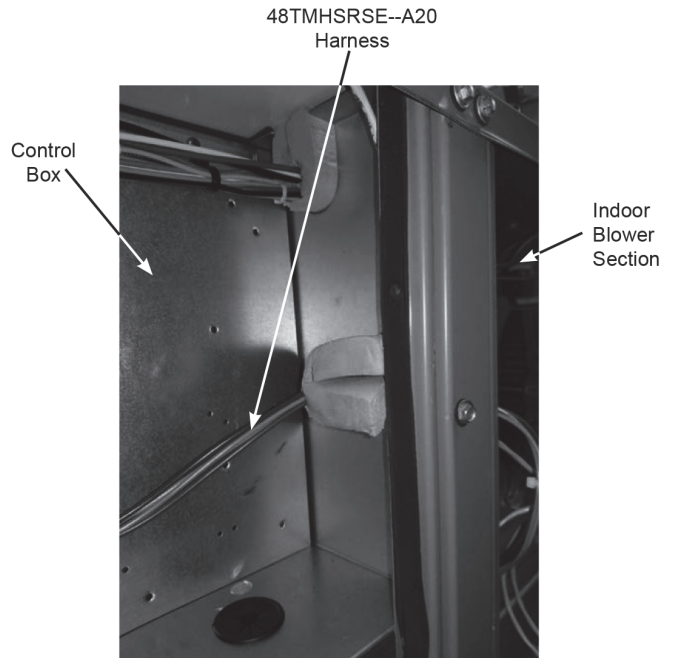

NOTE: Some control box configurations may differ.

Fig. 14 — Route 48TMHSRSE--A20 Harness to Indoor Blower Section

19. Screw the HH79ZZ007 mixed air (MAT) sensor to the left side edge of indoor blower through pre-punched holes, see Fig. 15. Confirm that the screws do not interfere with blower rotation. Connect the (2) spade terminals on the HH79ZZ007 sensor to the orange and brown wires from the 4-wire 48TMHSRSE--A20 Harness. See Fig. 15 and 23.

BROWN AND ORANGE WIRE FROM 9962-0407-SAOEXT

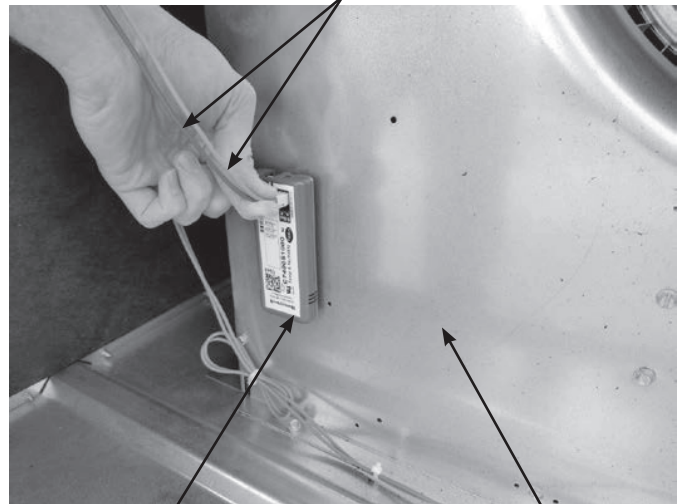

MIXED AIR TEMPERATURE SENSOR 9901-2021

INDOOR BLOWER

Fig. 15 — Mount and Connect Mixed Air Sensor

20. Connect the pink and violet wires from the 4-wire 48TMHSRSE--A20 harness to the pink and violet terminals in the wire bundle in the indoor blower section. See Fig. 16 and 23.

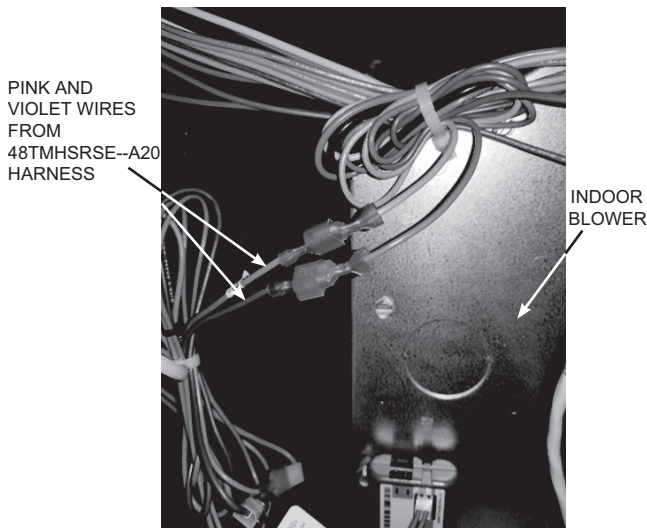
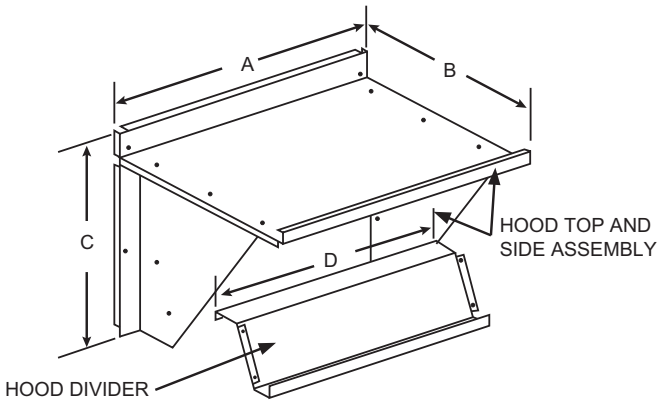

Fig. 16 — Connect Pink and Violet Wires in Indoor Blower Section

21. If using differential return sensor or DCV sensor, install it now. See installation details later in the instructions and the wiring diagram for further information.
22. Assemble the EconoMi\$er X hood by screwing the hood divider to the hood subassembly (top and sides). See Fig. 17. Note on the CRECOMZR080A00 there is also a center hood filter divider – screw in place. See Fig. 18.



ECONOMIZER P/N	A	B	C	D	SHIP WT.
CRECOMZR076A00	30.37"	17.43"	19.05"	29.5"	55 lb
CRECOMZR078A00	40.37"	22.28"	24.48"	36.27"	80 lb
CRECOMZR080A00	52.92"	27.03"	33.41"	49.92"	98 lb

NOTE: The CRECOMZR080A00 hood has 2 aluminum filters and a hood filter divider that installs between the filters.

Fig. 17 — EconoMi\$er® X Hood Assembly

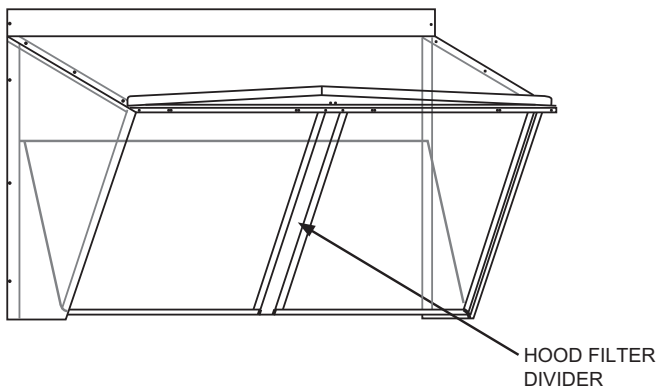

Fig. 18 — Filter Divider on CRECOMZR080A00 Hood

23. Install aluminum filter(s) in EconoMi\$er X hood. Clips at top of hood will hold filters in place. See Fig. 19.

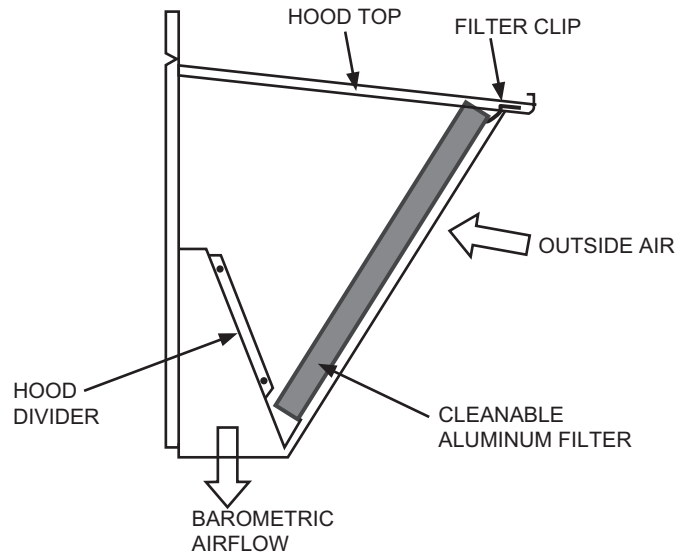

Fig. 19 — Fully Assembled Hood

24. Install EconoMi\$er X hood over economizer. Screw hood in place through pre-punched holes. Reinstall the unit's filter access door. See Fig. 20. Re-install the Indoor blower access panel. See Fig. 6.



Fig. 20 — Install EconoMi\$er X Hood and Unit Filter Access Door

25. After powering unit controller, program the W7220 controller per the instructions to follow. See Table 10 for summarized controller set-up instructions. After all settings have been made, re-install the unit control box panel. See Fig. 6.

Economizer performance charts are shown in Fig. 21 and 22. See base unit installation manual to make adjustments to meet building ventilation requirements.

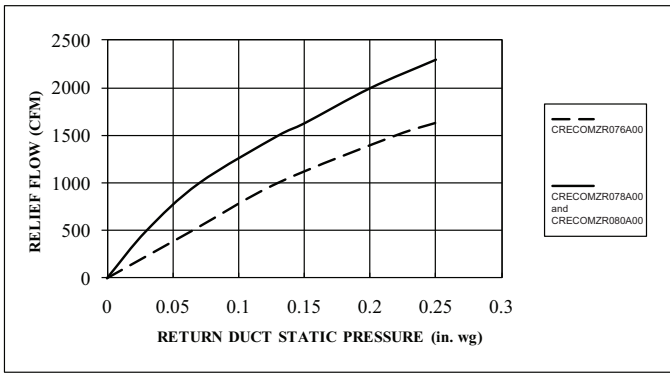

Fig. 21 — Barometric Relief Flow Capacity

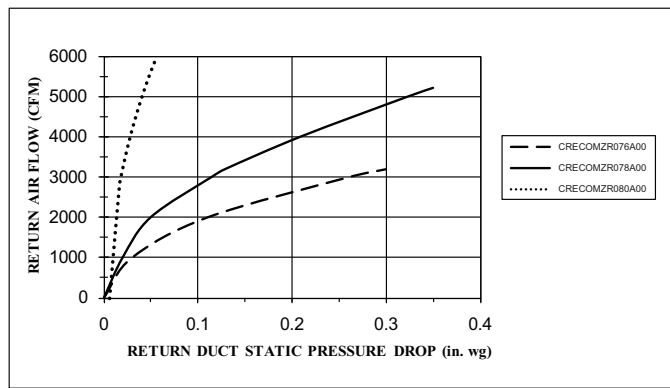

Fig. 22 — Return Air Pressure Drop

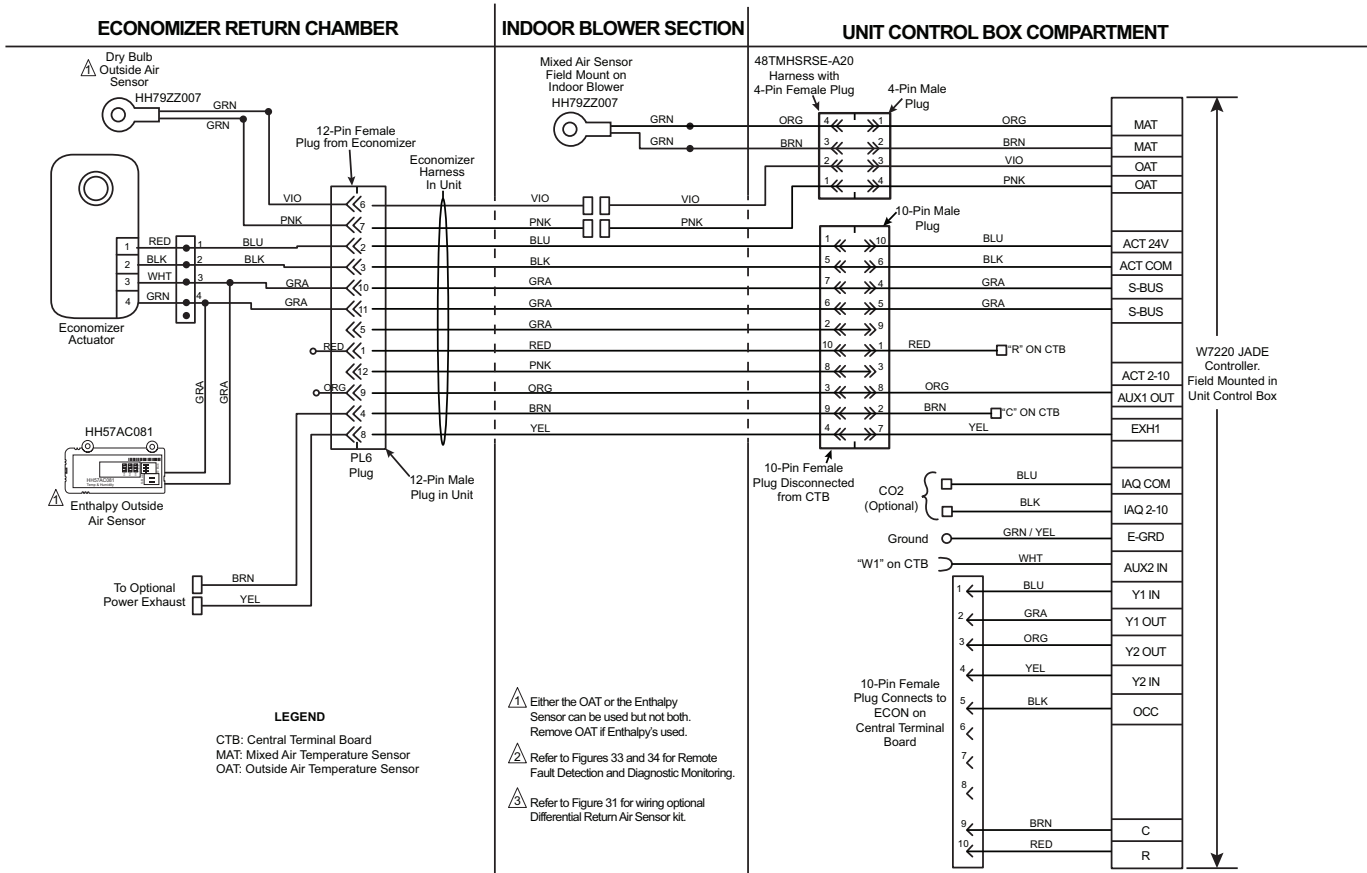

Fig. 23 — Typical EconoMiSer X Wiring Diagram for 1 or 2 Speed Units (Not for 48/50LC 07-12 Units)

Installation Instructions for 48/50LC 07-12 Units ONLY

IMPORTANT: This section is for economizer installation instructions on 48/50LC 07-12 units only.

1. Follow steps 1 through 10 on page 3-4.
2. The 48/50LC 07-12 units require different wiring than is factory-attached to the W7220 controller. Disconnect the complete wiring harness factory-attached to the W7220 controller, as shown below in Fig. 24. This harness can be discarded.



Fig. 24 — Remove Complete Harness Factory-Attached to W7220 Controller

NOTE: The 4-wire 48TMHSRSE--A20 harness provided with the economizer will also NOT be used on the 48/50LC07-12 units (see Fig. 25).



Fig. 25 — 48TMHSRSE--A20 NOT Used on 48/50LC 07-12 Units

3. The 48/50LC 07-12 units that do not have a factory-installed economizer will have a new W7220 controller wiring harness shipped in the control box section of the HVAC unit. This harness, Carrier part number 48LCHSRADH--A00, is shown in Fig. 26 and 27.

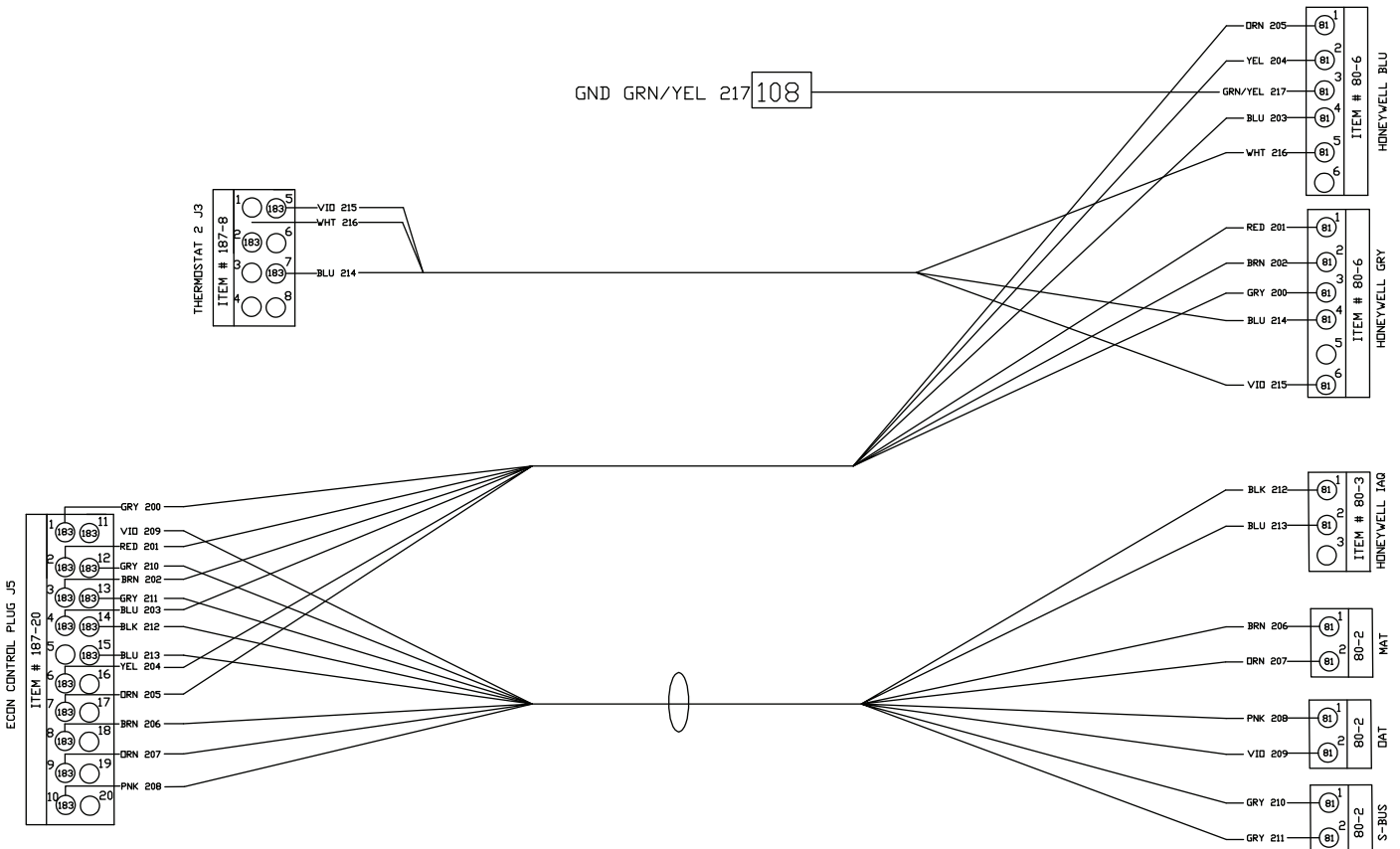

Fig. 26 — 48LCHSRADH--A00 W7220 Controller Harness Shipped With 48/50LC 07-12 Units



Fig. 27 — 48LCHSRADH--A00 W7220 Controller Harness Shipped With 48/50LC 07-12 Units

4. The connectors on the right side of Fig. 26 on the 48LCHSRADH--A00 harness attach to the W7220 controller installed in the unit control box. See Fig. 26 and 28. 48LCHSRADH--A00 harness connectors are labeled to easily identify the plug-in location on the controller.
5. Locate the Compressor Staging Control (CSC) board in the HVAC unit. When a field-installed economizer is used, the J5 jumper on the CSC must be removed. Remove the J5 jumper. See Fig. 28.
6. The connectors on the left side of Fig. 26 on the 48LCHSRADH--A00 harness attach to the unit's CSC board. Connect J3 and J5 plugs to the CSC board.

7. Screw the green wire with yellow stripe in the 48LCHSRADH--A00 harness to the control box (ground). See Fig. 12 and 28.
8. Mount the provided HH79ZZ007 mixed-air temperature (MAT) sensor to the indoor blower. Confirm that the screws do not interfere with blower rotation. See Fig. 15. Connect the (2) spade terminals on the HH79ZZ007 sensor to orange and brown wires in the indoor blower section wire bundle.
9. Follow steps 21 through 25 on page 7 in this book.

Installing Optional HH57AC081 Single Outside Air Enthalpy Sensor

When using the HH57AC081 (Honeywell C7400S) enthalpy sensor (see Fig. 30) for outside air changeover, the existing HH79ZZ007 dry bulb sensor must be removed. The enthalpy sensor will be mounted in the same location as the dry bulb sensor (see Fig. 1). When the enthalpy sensor's OA temperature, enthalpy and dew point are below the respective setpoints, the outside air can be used for free-cooling. When any of these is above the setpoint, free-cooling will not be available. Figure 29 shows the enthalpy boundaries in the W7220 controller. There are (5) enthalpy boundaries (setpoints ES1 thru ES5), which are defined by dry bulb temperature, enthalpy, and dew point. ES3 is the default setting. Table 7 shows the High Limit Curves for each setting.

NOTE: To use the HH57AC081 sensor for outside air sensor, the dipswitches on the sensor must be set to OFF-OFF-OFF. See Table 8.

The (2) gray wires with a plug from the EconoMiSer X harness in the return chamber plug directly into the HH57AC081 enthalpy sensor. See Fig. 23 and 28 for wiring.

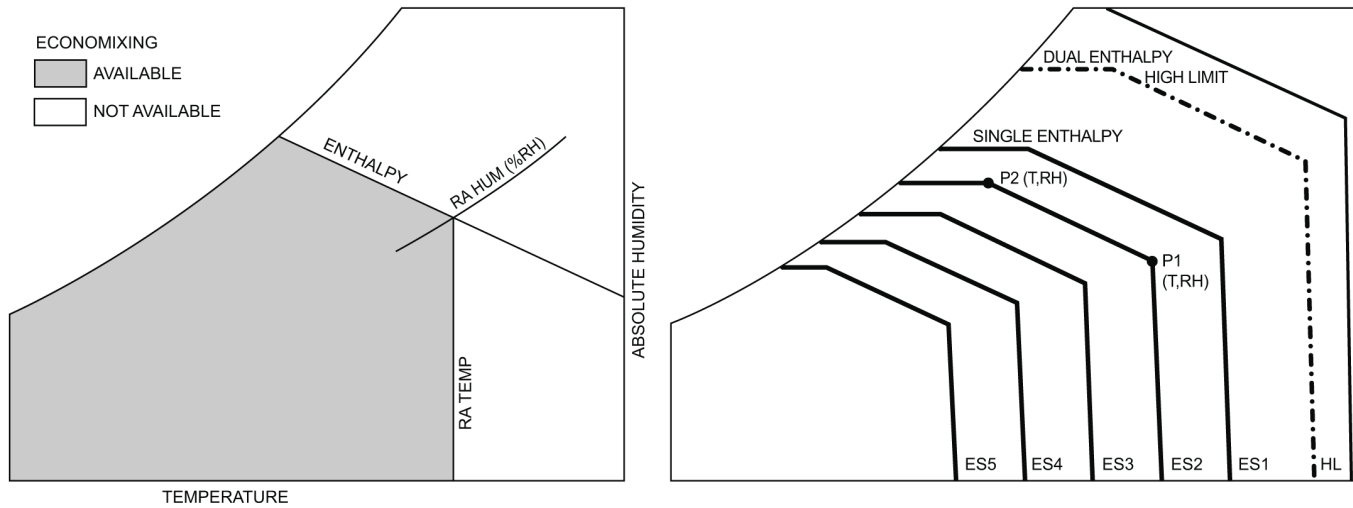
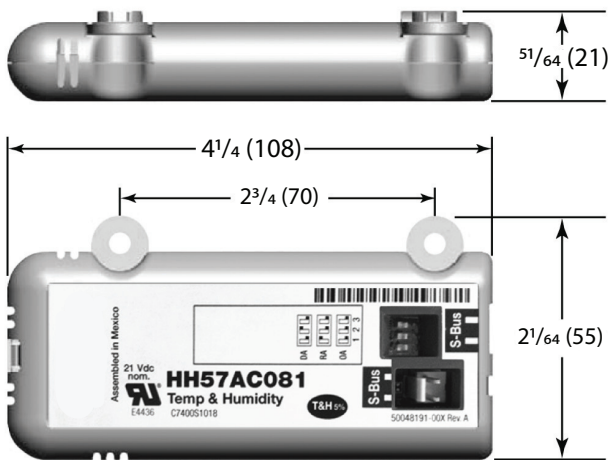

Fig. 29 — Enthalpy Curve Boundaries

Table 7 — Single Enthalpy and Dual Enthalpy High Limit Curves

ENTHALPY CURVE	TEMP. DRY BULB (F)	TEMP. DEWPOINT (F)	ENTHALPY (btu/lb/da)	POINT P1		POINT P2	
				TEMP. (F)	HUMIDITY (%RH)	TEMP. (F)	HUMIDITY (%RH)
ES1	80	60	28.0	80	36.8	66.3	80.1
ES2	75	57	26.0	75	39.6	63.3	80.0
ES3	70	54	24.0	70	42.3	59.7	81.4
ES4	65	51	22.0	65	44.8	55.7	84.2
ES5	60	48	20.0	60	46.9	51.3	88.5
HL	86	66	32.4	86	38.9	72.4	80.3



NOTE: Dimensions in () are in mm

Fig. 30 — HH57AC081 Dimensional, Connection and Switching information

Table 8 — HH57AC081 Sensor DIP Switch

USE	DIP SWITCH POSITIONS FOR SWITCHES 1,2, & 3		
	1	2	3
DA	OFF	ON	OFF
RA	ON	OFF	OFF
OA	OFF	OFF	OFF

LEGEND

- DA — Discharge Air or Supply Sensor
 - RA — Return Air
 - OA — Outside Air
- Default setting is OFF-OFF-OFF

Installing Differential Return Air Sensor

The CRDIFRASN01A00 differential return sensor kit must be field mounted in the system's return duct work. The kit includes a wiring harness that connects the EconoMiSer X harness in the return chamber of the unit to the provided HH57AC081 sensor. Wire according to Fig. 31.

In addition to using the HH57AC081 (Honeywell C7400S) sensor (see Fig. 30) for a single enthalpy sensor, it can also be used as a differential return enthalpy or dry bulb sensor. Figure 29 shows the dual enthalpy boundaries in the W7220 controller. With dual enthalpy, The HIGH LIMIT boundary is ES1 when there are no stages of mechanical cooling energized and HL (high limit) when a compressor stage is energized. Table 7 shows the High Limit Curves for each setting.

NOTE: To use the HH57AC081 sensor for differential return air, the dipswitches on the sensor must be set to ON-OFF-OFF. See Table 8.

When using the CRDIFRASN01A00 differential return enthalpy or dry bulb temperature option, see Table 9 for California Title 24 setting requirements by region.

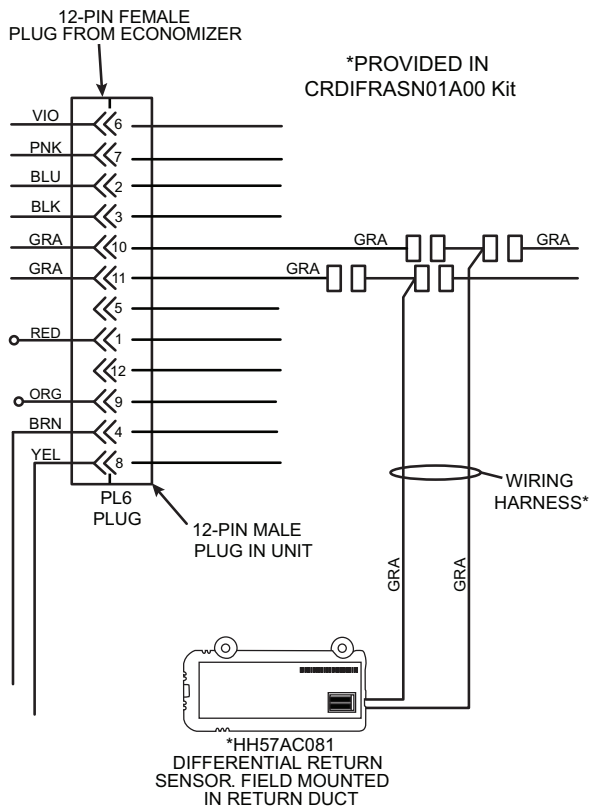

Fig. 31 — Wiring Differential Return-Air Sensor

California's Title 24 High Temperature Limit Settings

California's Title 24 code requires a high temperature limit setting for all dry bulb outside air economizer change over. The temperatures vary by the region within California. See Table 9 for high limit settings.

Table 9 — California Title 24 Regional High Limit Dry Bulb Temperature Settings

TABLE 140.4-B AIR ECONOMIZER HIGH LIMIT SHUT OFF CONTROL REQUIREMENTS

DEVICE TYPE*	CLIMATE ZONES	REQUIRED HIGH LIMIT (ECONOMIZER OFF WHEN):
		DESCRIPTION
Fixed Dry Bulb	1, 3, 5, 11-16	OAT exceeds 75°F
	2, 4, 10	OAT exceeds 73°F
	6, 8, 9	OAT exceeds 71°F
	7	OAT exceeds 69°F
Differential Dry Bulb	1, 3, 5, 11-16	OAT exceeds RA temperature
	2, 4, 10	OAT exceeds return air temperature minus 2°F
	6, 8, 9	OAT exceeds return air temperature minus 4°F
	7	OAT exceeds return air temperature minus 6°F
Fixed Enthalpy† + Fixed Dry Bulb	All	OAT exceeds 28 Btu/lb of dry air† or OAT exceeds 75°F

* Only the high limit control devices listed are allowed to be used and at the set points listed. Others such as Dew Point, Fixed Enthalpy, Electronic Enthalpy, and Differential Enthalpy Controls, may not be used in any climate zone for compliance with Section 140.4(e)1 unless approval for use is provided by the Energy Commission Executive Director.

† At altitudes substantially different than sea level, the Fixed Enthalpy limit value shall be set to the enthalpy value at 75°F and 50% relative humidity. As an example, at approximately 6,000 foot elevation, the fixed enthalpy limit is approximately 30.7 Btu/lb.

Demand Controlled Ventilation

Refer to EconoMiSer X wiring diagram (Fig. 23 and 28) and DCV instructions if demand controlled ventilation (CO₂ sensor) is used. The CO₂ sensor will wire into the blue and black connections at the controller as shown in Fig. 23, 28, and 32. If a field-installed CO₂ sensor is connected to the EconoMiSer X controller, a demand controlled ventilation strategy will operate automatically. As the CO₂ level in the space increases above the setpoint (on the EconoMiSer X controller), the minimum position of the dampers will be increased proportionally, until the Maximum Ventilation setting is reached. As the space CO₂ level decreases because of the increase in fresh air, the outdoor damper will follow the higher demand condition from the DCV mode or from the free cooling mode.

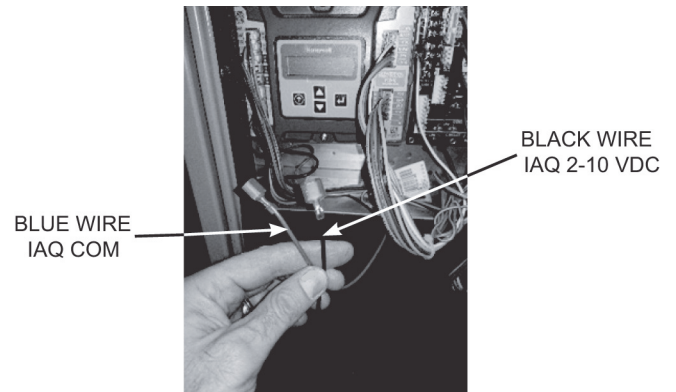

Fig. 32 — CO₂ Wiring Connections to Controller

Remote (Downstairs) Monitoring of Controller's Fault Detection and Diagnostics

Many codes including IECC, Title 24, and ASHRAE 90.1 require that the economizer's faults be accessible by operating or service personal, or annunciated locally on zone thermostat. To setup remote monitoring on the controller, under SYSTEM SETUP, AUX1-OUT must be set to SYS.

The latest versions of Honeywell's TH8321WF or TH8321R thermostats are options for meeting this requirement. Fig. 33 shows an example of the thermostat wiring to the controller.

Follow instructions provided with Honeywell thermostat. Another option that is acceptable to some codes is an annunciator light visible by service personnel. See Fig. 34 for typical wiring to the controller. Refer to codes for proper labeling of light.

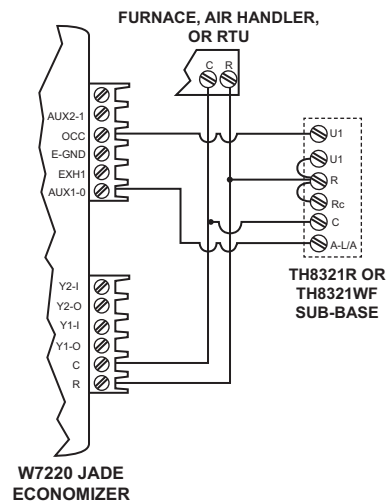
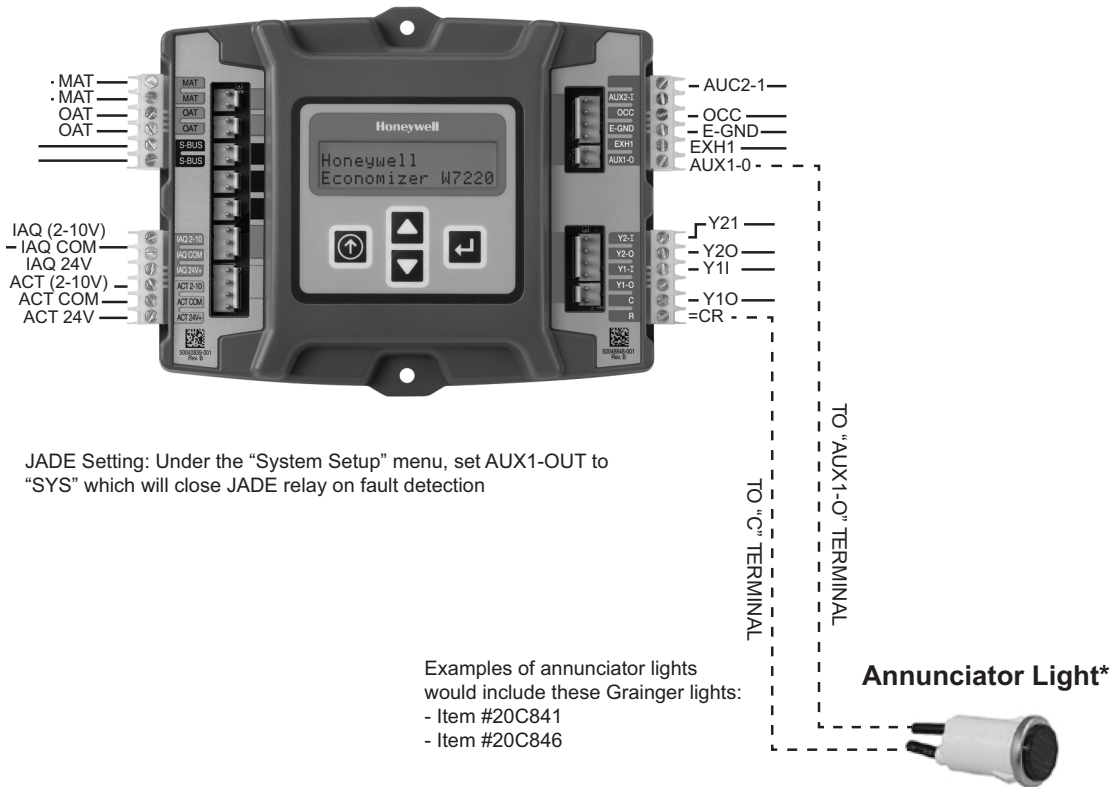

Fig. 33 — Thermostat Wired For Remote FDD

W7220 Economizer Controller Module



JADE Setting: Under the "System Setup" menu, set AUX1-OUT to "SYS" which will close JADE relay on fault detection

Examples of annunciator lights would include these Grainger lights:
 - Item #20C841
 - Item #20C846

Fig. 34 — Annunciator Light Wired for Remote FDD

GENERAL W7220 CONTROLLER AND SENSOR INFORMATION

W7220 Economizer

The economizer controller used on electromechanical units is a Honeywell W7220, which is located in the RTU base unit's Control Box. See the base unit's Installation Instructions for the location of the Control Box access panel.

The W7220 controller provides the following:

- 2-line LCD interface screen for setup, configuration, and troubleshooting.
- On-board fault detection and diagnostics
- Sensor failure loss of communications identification
- Automatic sensor detection
- Capabilities for use with multiple-speed indoor fan systems

User Interface

The user interface consists of a LCD display and a 4-button keypad on the front of the economizer controller.

Keypad

The four navigation buttons (see Fig. 35) are used to scroll through the menus and menu items, to select menu items, and to change parameter and configuration settings.

Using the Keypad with Menus

To use the keypad when working with menus:

- Press the ▲ (Up arrow) button to move to the previous menu.
- Press the ▼ (Down arrow) button to move to the next menu.
- Press the ↵ (Enter) button to display the first item in the currently displayed menu.

- Press the ⬆ (Menu Up/Exit) button to exit a menu's item and return to the list of menus.

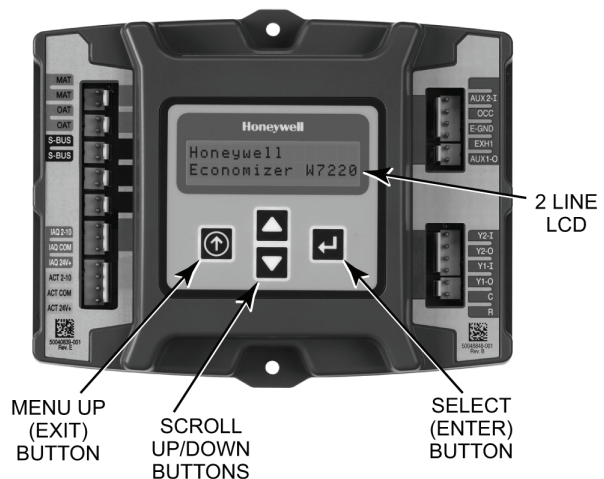

Fig. 35 — W7220 Controller

Using the Keypad with Settings and Parameters

To use the keypad when working with set points, system and advanced settings, checkout tests, and alarms:

1. Navigate to the desired menu.
2. Press the ↵ (Enter) button to display the first item in the currently displayed menu.
3. Use the ▲ and ▼ buttons to scroll to the desired parameter.
4. Press the ↵ (Enter) button to display the value of the currently displayed item.
5. Press the ▲ button to increase the displayed parameter value.

- Press the ▼ button to decrease the displayed parameter value.

NOTE: When values are displayed, pressing and holding the ▲ or ▼ button causes the display to automatically increment.

- Press the ↵ (Enter) button to accept the displayed value and store it in nonvolatile RAM.
- The message “CHANGE STORED” displays.
- Press the ↵ (Enter) button to return to the current menu parameter.
- Press the ⏴ (Menu Up/Exit) button to return to the previous menu.

Programming the W2770 Controller

The next several pages detail the different status displays, set points, setup, and alarms available on the controller. The list below and Table 10 summarize the inputs required for a standard application with a single outside air sensor.

NOTE: Instead of setting the SETPOINTS, you can use the defaults already set in the controller – see default settings below. See Table 10 for summarized standard settings or, for more detail, see Table 11 – Menu Structure.

SETPOINTS

- MAT SET:** this sets the mixed air temperature (MAT) setting. The controller has a default of 53°F, but the range is anywhere from 38°F to 70°F.
- LOW T LOCK:** This setting locks out the compressor (or mechanical cooling) at a given temperature. The default is 32°F, but the controller’s range is from –45°F to 80°F.
- DRYBULB SET:** if you have an economizer with a dry bulb outside air sensor, you will see and set the DRYBULB SET. The default setting is 63°F but the controller’s range is 48°F to 80°F.
- ENTH CURVE:** if you have a single enthalpy outside air sensor instead of a dry bulb, you will see and set the ENTH CURVE setting. There are 5 setting options: ES1 thru ES5. Check Table 7 for the limits for each of these settings. ES3 is the default setting.
- MIN POS:** The minimum position allows for ventilation even when not in the free-cooling mode. If you have a single speed unit there will be only one minimum position setting. The default is 4.4 volts, but the range is 2 to 10 vdc.

- MIN POS H and MIN POS L:** If your unit is 2 speed, there will be 2 minimum position settings that show up on the menu. The first is MIN POS H (for high speed), which has a default of 4.4-v. The second is MIN POS L (for low speed), which has a default of 6.0-v. Note that MIN POS H and MIN POS L are only displayed if under SYSTEM SETUP, AUX2 IN is set to “W1”, and FAN TYPE is set to 2 speed.

SYSTEM SETUP

- INSTALL:** Allows you to set the current date. Use the keypad buttons to scroll to the correct date.
- EQUIPMENT:** Always set to CONV even if the unit is a heat pump.
- AUX2 IN:** Always set to W.
- FAN TYPE:** Set for either single speed or 2 speed. The default setting is 2 speed.
- AUX OUT:** If remote Fault Detection and Diagnostic (FDD) monitoring is required, select SYS.

OCC: occupancy, always set to INPUT

Menu Structure

Table 11 illustrates the complete hierarchy of menus and parameters for the EconoMiSer X system.

The Menus in display order are:

- STATUS
- SETPOINTS
- SYSTEM SETUP
- ADVANCED SETUP
- CHECKOUT
- ALARMS

IMPORTANT: The default setting on the W7220 controller is for a “Fan Type” with 2 speed, which is correct for 2 or 3 speed units (48/50LC 07-12). For a 1 (single) speed unit, the setting under SYSTEM SETUP > FAN TYPE must be changed to 1 speed.

IMPORTANT: Table 11 illustrates the complete hierarchy. Menu parameters may be different depending on configuration. For example, none of the DCV parameters appear for a system that does not have a DCV (CO₂) sensor.

Table 10 — Standard W7220 Controller Configuration

	CONTROLLER MENU ITEM	FOR SINGLE SPEED UNIT		FOR 2 SPEED UNIT		NOTE
		Default	Set to:	Default	Set To:	
SET POINTS	MAT SET	53°F	38°F to 70°F	53°F	38°F to 70°F	
	LOW T LOCK	32°F	–45°F to 80°F	32°F	–45°F to 80°F	
	DRYBLB SET	63°F	48°F to 80°F	63°F	48°F to 80°F	Only displayed if using single DB OA sensor
	ENTH CURVE	ES3	ES1 to ES5	ES3	ES1 to ES5	Only displayed if using a single enthalpy OA sensor
	MIN POS	4.4 vdc	2 to 10 vdc	n/a	n/a	Only displayed if set up for single speed unit
	MIN POS H	n/a	n/a	4.4 vdc	2 to 10 vdc	Only displayed if set up for 2 speed unit
	MIN POS L	n/a	n/a	6.0 vdc	2 to 10 vdc	Only displayed if set up for 2 speed unit
SYSTEM SETUP	INSTALL	1/1/2010	Current date	1/1/2010	Current date	
	EQUIPMENT	CONV	CONV	CONV	CONV	Always set to CONV, even on HP units
	AUX2 IN	W	W	W	W	Always set to W
	FAN TYPE	2 speed	1 speed	2 speed	2 speed	See Note 3
	AUX1 OUT	NONE	SYS	NONE	SYS	Set to SYS for remote FDD monitoring
	OCC	INPUT	INPUT	INPUT	INPUT	Always set to INPUT

n/a — Not applicable

NOTES:

- For 2 speed unit, under SYSTEM SETUP: EQUIPMENT= CONV, AUX2 I = W, and FAN TYPE = 2 SPEED
- More sophisticated controller setups, including for DCV or power exhaust, are available by referring to Table 11 options

3. Fan speed options are:

- 1 Speed
- 2 Speed
- 2 Speed: 1 Heat, 1 Cool.
- 3 Speed: 1 Heat, 2 Cool.

4. Do not use 3 speed setting for LC units.

Table 11 — Menu Structure¹

MENU	PARAMETER	PARAMETER DEFAULT VALUE	PARAMETER RANGE AND INCREMENT ²	NOTES
STATUS	ECON AVAIL	NO	YES/NO	ECONOMIZING AVAILABLE YES = economizing available; the system can use outside air for free cooling when required
	ECONOMIZING	NO	YES/NO	ECONOMIZING ACTIVE YES = Outside air being used for first stage cooling NO = Economizing not active
	OCCUPIED	NO	YES/NO	OCCUPIED YES = OCC signal received from space thermostat or unitary controller YES = 24 vac on terminal OCC. NO = 0 vac on terminal OCC.
	HEAT PUMP	n/a	COOL HEAT	HEAT PUMP MODE (Not available on 2-speed configuration)
	COOL Y1-IN	OFF	ON/OFF	FIRST STAGE COOLING DEMAND (Y1-IN) Y1-I signal from space thermostat or unitary controller for cooling stage 1. ON = 24 vac on terminal Y1-I OFF = 0 vac on terminal Y1-I
	COOL Y1-OUT	OFF	ON/OFF	FIRST STAGE COOLING RELAY OUTPUT ON = 24 vac on terminal Y1-O; Stage 1 mechanical cooling called on OFF = 0 vac on terminal Y1-O; no mechanical cooling
	COOL Y2-IN	OFF	ON/OFF	SECOND STAGE COOLING DEMAND (Y2-IN) Y2-I signal from space thermostat our unitary controller for second stage cooling. ON = 24 vac on terminal Y2-I OFF = 0 vac on terminal Y2-I
	COOL Y2-OUT	OFF	ON/OFF	SECOND STAGE COOLING RELAY OUTPUT ON = 24 vac on terminal Y2-O; stage 2 mechanical cooling called on OFF = 0 vac on terminal Y2-O; no stage 2 mechanical cooling
	MA TEMP	___ . ___ °F (or °C)	0°F to 140°F (-18°C to 60 °C)	MIXED AIR TEMPERATURE, Cooling Mode Displays value of measured mixed air from MAT sensor. Displays ___ . ___ if not connected, short or out-of-range.
	DA TEMP	___ . ___ °F (or °C)	0°F to 140°F (-18°C to 60 °C)	DISCHARGE AIR TEMPERATURE, after Heating section (Accessory sensor required) Displays when Discharge Air sensor is connected and displays measured discharge temperature. Displays ___ . ___ if sensor sends invalid value, if not connected, short or out-of-range.
	OA TEMP	___ . ___ °F (or °C)	-40°F to 140°F (-40°C to 60°C)	OUTSIDE AIR TEMPERATURE Displays measured value of outdoor-air temperature. Displays ___ . ___ if sensor sends invalid value, short or out-of-range.
	OA HUM	__%	0 to 100%	OUTSIDE AIR RELATIVE HUMIDITY Displays measured value of outdoor humidity from OA sensor. Displays __% if not connected, short, or out-of-range.
	RA TEMP	___ . ___ °F (or °C)	0°F to 140°F (-18°C to 60°C)	RETURN AIR TEMPERATURE Displays measured value of return air temperature from RAT sensor. Displays ___ . ___ if sensor sends invalid value, if not connected, short or out-of-range
	RA HUM	__%	0 to 100%	RETURN AIR RELATIVE HUMIDITY Displays measured value of return air humidity from RA sensor. Displays __% if sensor sends invalid value, if not connected, short or out-of-range
	IN CO2	___ ppm	0 to 2000 ppm	SPACE/RETURN AIR CO ₂ (CO ₂ sensor required, accessory or factory option) Displays value of measured CO ₂ from CO ₂ sensor. Invalid if not connected, short or out-of-range
	DCV STATUS	n/a	ON/OFF	DEMAND CONTROLLED VENTILATION STATUS (CO ₂ sensor required, accessory or factory option) Displays ON if above set point and OFF if below set point, and ONLY if a CO ₂ sensor is connected.
	DAMPER OUT	2.0V	2.0 to 10.0-v	Displays voltage output to the damper actuator. 0% = OA Damper fully closed 100%= OA Damper full open
	ACT POS	__%	0 to 100%	Displays actual position of outdoor air damper actuator 2.0-v = OA Damper fully closed 10.0-v = OA Damper full open
	ACT COUNT	n/a	1 to 65535	Displays number of times actuator has cycled. 1 cycle equals accrued 180° of actuator movement in any direction
	ACTUATOR	n/a	OK/Alarm (on Alarm menu)	Displays Error if voltage or torque is below actuator range
EXH1 OUT	OFF	ON/OFF	EXHAUST STAGE 1 RELAY OUTPUT Output of EXH1 terminal: ON = relay closed OFF = relay open	
EXH2 OUT	OFF	ON/OFF	EXHAUST STAGE 2 RELAY OUTPUT Output of AUX terminal; displays only if AUX = EXH2 ON = relay closed OFF = relay open	

Table 11 — Menu Structure¹ (cont)

MENU	PARAMETER	PARAMETER DEFAULT VALUE	PARAMETER RANGE AND INCREMENT ²	NOTES
STATUS (cont)	ERV ³	OFF	ON/OFF	ENERGY RECOVERY UNIT RELAY OUTPUT Output of AUX terminal; displays only if AUX = ERV ON = relay closed OFF = relay open
	MECH COOL ON	0	0,1, or 2	Displays stage of mechanical cooling that is active.
	FAN SPEED	n/a	LOW or HIGH	SUPPLY FAN SPEED Displays speed setting of fan on a 2-speed fan unit.
	W (HEAT ON)	n/a	ON/OFF	HEAT DEMAND STATUS Displays status of heat demand on a 2-speed fan unit.
SETPOINTS	MAT SET	53°F (12°C)	38°F to 65°F (3°C to 18°C); increment by 1°	MIXED AIR SET POINT Set point determines where the economizer will modulate the OA damper to maintain the mixed air temperature.
	LOW T LOCK	32°F (0°C)	-45°F to 80°F (-43°C to 27°C); increment by 1°	COMPRESSOR LOW TEMPERATURE LOCKOUT Set point determines outdoor temperature when the mechanical cooling cannot be turned on. Commonly referred to as the compressor lockout.
	DRYBLB SET	63°F (17°C)	48°F to 80°F (9°C to 27°C); increment by 1°	OA DRY BULB TEMPERATURE CHANGEOVER SETPOINT Setpoint determines where the economizer will assume outdoor air temperature is good for free cooling; e.g.: at 63°F (17°C), unit will economize at 62°F (16.7°C) and below and not economize at 64°F (17.8°C) and above. There is a 2°F (1.1°C) deadband. DRYBULB SET is only displayed if the economizer has a single dry bulb sensor
	DRYBLB DIFF	0°F	0°F to 6°F; increment by 2°F	Dry bulb Differential will only show if using dual dry bulb - i.e. when an outdoor air temperature sensor C7250 is attached to OAT terminals and C7400S sensor is wired to S-Bus and configured for RAT (return air). Free cooling will be assumed whenever OA temp is at or below RAT minus this dry bulb setting.
	ENTH CURVE	ES3	ES1,ES2,ES3,ES4, or ES5	ENTHALPY CHANGEOVER CURVE (Requires enthalpy sensor option) Enthalpy boundary "curves" for economizing using single enthalpy
	DCV SET	1100ppm	500 to 2000ppm; increment by 100	DEMAND CONTROLLED VENTILATION SET POINT Displays only if CO ₂ sensor is connected. Set point for Demand Control Ventilation of space. Above the set point, the OA dampers will modulate open to bring in additional OA to maintain a space ppm level below the set point.
	MIN POS	4.4 V	2 to 10 vdc	VENTILATION MINIMUM POSITION. Only displayed if controller is set for single speed unit under FAN TYPE, and if DCV is NOT used.
	MIN POS L	6.0V	2 to 10 vdc	VENTILATION MINIMUM POSITION AT LOW SPEED. Only displays if unit is set for 2 or 3 speed and CO ₂ is not used. IF using 2 speed with 1 heat and 1 cool then set for HEATING ventilation. If using 3 speed with 1 heat and 2 cool then set for LOW SPEED COOLING ventilation.
	MIN POS M	5.4V	2 to 10 vdc	VENTILATION MINIMUM POSITION AT MEDIUM SPEED. Only displays if unit is set for 3 speed with 1 heat and 2 cool, and CO ₂ is not used. Set for HEATING ventilation.
	MIN POS H	4.4V	2 to 10 vdc	VENTILATION MINIMUM POSITION AT HIGH SPEED. Only displays if unit is set for 2 or 3 speed and CO ₂ is not used. IF using 2 speed with 1 heat and 1 cool then set for COOLING ventilation. If using 3 speed with 1 heat and 2 cool then set for HIGH SPEED COOLING ventilation
	VENTMAX L	6.0 V	2 to 10 vdc	DCV MAXIMUM DAMPER POSITION AT LOW SPEED Displays only if a CO ₂ sensor is connected. Used for Vbz (ventilation max cfm) set point. Displays 2 to 10 V if <3 sensors (RA,OA, and MA). In AUTO mode dampers controlled by CFM
	VENTMAX M	5.4 V	2 to 10 vdc	DCV MAXIMUM DAMPER POSITION AT MEDIUM SPEED. Only displays if unit is set for 3 speed with 1 heat and 2 cool. Set for HEATING ventilation.
	VENTMAX H	4.4 V	2 to 10 vdc	DCV MAXIMUM DAMPER POSITION AT HIGH SPEED. Only displays if unit is set for 2 speed or 3 speed with 1 heat and 2 cool. IF using 2 speed with 1 heat and 1 cool then set for COOLING ventilation. If using 3 speed with 1 heat and 2 cool then set for HIGH SPEED COOLING ventilation
	VENTMIN L	3.7 V	2 to 10 vdc	DCV MINIMUM DAMPER POSITION AT LOW SPEED. Only displays if unit is set for 2 speed or 3 speed with 1 heat and 2 cool. IF using 2 speed with 1 heat and 1 cool then set for HEATING ventilation. If using 3 speed with 1 heat and 2 cool then set for LOW SPEED COOLING ventilation
	VENTMIN M	3.4 V	2 to 10 vdc	DCV MINIMUM DAMPER POSITION AT MEDIUM SPEED. Only displays if unit is set for 3 speed with 1 heat and 2 cool. Set for HEATING ventilation.
VENTMIN H	2.8 V	2 to 10 vdc	DCV MINIMUM DAMPER POSITION AT HIGH SPEED. Only displays if unit is set for 2 speed or 3 speed with 1 heat and 2 cool. IF using 2 speed with 1 heat and 1 cool then set for COOLING ventilation. If using 3 speed with 1 heat and 2 cool then set for HIGH SPEED COOLING ventilation	

Table 11 — Menu Structure¹ (cont)

MENU	PARAMETER	PARAMETER DEFAULT VALUE	PARAMETER RANGE AND INCREMENT ²	NOTES
SETPOINTS (cont)	ERV OAT SP	32°F (0°C)	0°F to 50°F (-18°C to 10°C); increment by 1°	ENERGY RECOVERY VENTILATION UNIT OUTDOOR AIR TEMPERATURE SETPOINT Only displayed when AUX1 O = ERV
	EXH1 SET	50%	0 to 100%	Exhaust fan set point for single speed units. Based on OA Damper position to activate power exhaust.
	EXH1 L SET	65%	0 to 100%	EXHAUST FAN 1 SETPOINT AT LOW SPEED On 2 speed or 3 speed with 1 heat and 2 cool. Based on economizer OA damper position to activate power exhaust.
	EXH1 M SET	60%	0 to 100%	EXHAUST POINT 1 SETPOINT AT MEDIUM SPEED Only displays if unit is set for 3 speed with 1 heat and 2 cool. Based on economizer OA damper position to activate power exhaust.
	EXH2 H SET	50%	0 to 100%	EXHAUST FAN 1 SETPOINT AT HIGH SPEED On 2 speed or 3 speed with 1 heat and 2 cool. Based on economizer OA damper position to activate power exhaust.
	EXH2 L SET	80%	0 to 100%	EXHAUST FAN 2 SETPOINT AT LOW SPEED On 2 speed or 3 speed with 1 heat and 2 cool. Based on economizer OA damper position to activate power exhaust.
	EXH2 M SET	77%	0 to 100%	EXHAUST FAN 2 SETPOINT AT MEDIUM SPEED Only displays if unit is set for 3 speed with 1 heat and 2 cool. Based on economizer OA damper position to activate power exhaust.
	EXH2 H SET	75%	0 to 100%	EXHAUST FAN 2 SETPOINT AT HIGH SPEED On 2 speed or 3 speed with 1 heat and 2 cool. Based on economizer OA damper position to activate power exhaust.
SYSTEM SETUP	INSTALL	01/01/10		Display order = MM/DD/YY Setting order = DD, MM, then YY.
	UNITS DEG	°F	°F or °C	Sets economizer controller in degrees Fahrenheit or Celsius
	EQUIPMENT	CONV	Conventional or HP	Always set to CONV even for heat pump
	AUX2 I	W	W required for 2-speed mode	Always set to W
	FAN TYPE	2 speed	1 speed/2 speed	Sets the economizer controller to the number of unit fan speeds. Fan Type options: 1 Speed units 2 speed units *2 speed units: 1 for heat and 1 for cool *3 speed units: 1 for heat and 2 for cool
	* These Fan Type (speed) settings are for future use only. Do not use for 3 speed LC units.			
	FAN CFM	5000cfm	100 to 15000 cfm; increment by 100	UNIT DESIGN AIRFLOW (CFM) Enter ONLY if using DCVCAL ENA = AUTO
	AUX OUT	NONE	NONE ERV EXH2 SYS	• NONE = not configured (output is not used) • ERV = Energy Recovery Ventilation • EXH2 = second damper position relay closure for second exhaust fan • SYS = use output as an alarm signal
	OCC	INPUT	INPUT or ALWAYS	Always set to INPUT
	ADVANCED SETUP	MA LO SET	45°F (7°C)	35°F to 55°F (2°C to 12°C); incremented by 1°
FREEZE POS		CLO	CLO or MIN	FREEZE PROTECTION DAMPER POSITION Damper position when freeze protection is active CLO = closed MIN = MIN POS or VENTMIN
CO2 ZERO		0ppm	0 to 500 ppm; Increment by 10	CO ₂ ppm level to match CO ₂ sensor start level.
CO2 SPAN		2000ppm	1000 to 3000 ppm; Increment by 10	CO ₂ ppm span to match CO ₂ sensor.
STG3 DLY		2.0h	0 min, 5 min, 15 min, then 15 min intervals. Up to 4 h or OFF	COOLING STAGE 3 DELAY Delay after stage 2 for cool has been active. Turns on second stage of cooling when economizer is first stage and mechanical cooling is second. Allows three stages of cooling, 1 economizer and 2 mechanical. OFF = no Stage 3 cooling
SD DMPR POS		CLO	CLO or OPN	Function NOT AVAILABLE with 2-speed mode Indicates shutdown signal from space thermostat or unitary controller. When controller receives 24 vac input on the SD terminal in conventional mode, the OA damper will open if programmed for OPN and OA damper will close if programmed for CLO. All other controls, e.g., fans, etc. will shut off.
DCVCAL ENA		MAN	MAN (manual) AUTO	Turns on the DCV automatic control of the dampers. Resets ventilation based on the RA, OA, and MA sensor conditions. Requires all 3 RA, OA, and MA sensors. For single speed units only.
MAT T CAL		0.0°F (or °C)	±2.5°F (±1.4°C)	MIXED AIR TEMPERATURE CALIBRATION Allows for the operator to adjust for an out of calibration mixed air temperature (MAT) sensor

Table 11 — Menu Structure¹ (cont)

MENU	PARAMETER	PARAMETER DEFAULT VALUE	PARAMETER RANGE AND INCREMENT ²	NOTES	
ADVANCED SETUP (cont)	OA T CAL	0.0°F (or °C)	±2.5°F (±1.4°C)	OUTSIDE AIR TEMPERATURE CALIBRATION Allows for the operator to adjust for an out of calibration outside air temperature (OAT) sensor	
	OA H CAL	0% RH	±10% RH	OUTSIDE AIR HUMIDITY CALIBRATION Allows for the operator to adjust for an out of calibration outside air enthalpy sensor	
	RA T CAL	2.0°F (or °C)	±2.5°F (±1.4°C)	RETURN AIR TEMPERATURE CALIBRATION Allows for the operator to adjust for an out of calibration return air temperature (RA) sensor	
	RA H CAL	0% RH	±10% RH	RETURN AIR HUMIDITY CALIBRATION Allows for the operator to adjust for an out of calibration return air enthalpy sensor	
	DA T CAL	0.0°F (or °C)	±2.5°F (±1.4°C)	DISCHARGE AIR TEMPERATURE CALIBRATION Allows for the operator to adjust for an out of calibration discharge air temperature (DAT) sensor	
	2SP FAN DELAY	5 minutes	0 to 20 minutes in 1 minute increments	TIME DELAY ON SECOND STAGE ECONOMIZING While in the Economizing mode, this is the delay between thermostat Y2 call and Y1-O output to mechanical cooling stage, to allow high speed fan operation to attempt to cool space first.	
CHECKOUT	DAMPER VMIN-HS	n/a	n/a	Positions OA damper to VMIN High Speed position	
	DAMPER VMAX-HS	n/a	n/a	Positions OA damper to VMAX High Speed position	
	DAMPER OPEN	n/a	n/a	Position OA damper to the full open position. Exhaust fan contacts enable during the DAMPER OPEN test. Make sure to pause in the mode to allow exhaust contacts to energize due to the delay in the system.	
	DAMPER CLOSE	n/a	n/a	Positions damper to the fully closed position	
	CONNECT Y1-O	n/a	n/a	Closes the Y1-O relay (Y1-O)	
	CONNECT Y2-O	n/a	n/a	Closes the Y2-O relay (Y2-O)	
ALARMS(_)	CONNECT AUX1O	n/a	n/a	Energizes the AUX1O output. If Aux setting is: • NONE—no action taken • ERV—24 vac out. Turns on or signals an ERV that the conditions are not good for economizing but are for ERV operation. ³ • SYS—24 vac out. Issues a system alarm	
	Alarms display only when they are active. The menu title "ALARMS(_)" includes the number of active alarms in parenthesis (.). When using SYLK bus sensors, "SYLK" will appear on the screen, and when using 20k OA temperature sensors, "SENS T" will appear on the screen				
	MA T SENS ERR	n/a	n/a	MIXED AIR TEMPERATURE SENSOR ERROR Mixed air sensor has failed or become disconnected - check wiring then replace sensor if the alarm continues.	
	CO2 SENS ERR	n/a	n/a	CO ₂ SENSOR ERROR CO ₂ sensor has failed, gone out of range or become disconnected - check wiring, then replace sensor if the alarm continues.	
	OA SENS T ERR	n/a	n/a	OUTSIDE AIR TEMPERATURE SENSOR ERROR Outdoor-air temperature sensor has failed or become disconnected - check wiring (OAT sensor connected at input terminals OAT), then replace if the alarm continues.	
	OA SYLK SENS ERR	n/a	n/a	OUTSIDE AIR ENTHALPY SENSOR ERROR OAT sensor connected on S-bus.	
	DA T SENS ERR	n/a	n/a	DISCHARGE AIR TEMPERATURE SENSOR ERROR	
	SYS ALARM	n/a	n/a	When AUX1-O is set to SYS and there is any alarm (e.g., failed sensors, etc.), the AUX1-O terminal has 24 vac out.	
	ACT UNDER V	n/a	n/a	ACTUATOR VOLTAGE LOW Voltage received by Actuator is below expected range.	
	ACT OVER V	n/a	n/a	ACTUATOR VOLTAGE HIGH Voltage received by Actuator is over expected range.	
ACT STALLED	n/a	n/a	ACTUATOR STALLED Actuator stopped before achieving commanded position.		

LEGEND

- n/a — Not applicable
- LCD — Liquid Crystal Display
- MAT — Mixed Air Temperature
- OAT — Outdoor Air Temperature
- OCC — Occupied
- RAT — Return Air Temperature
- RTU — Rooftop Unit

¹Table 11 illustrates the complete hierarchy. Your menu parameters may be different depending on your configuration.
NOTES:

1. Table 11 illustrates the complete hierarchy. Menu parameters may be different depending on configuration. For example, none of the DCV parameters appear for a system that does not have a DCV (CO₂) sensor.
2. When values are displayed, pressing and holding the ▲ or ▼ button causes the display to automatically increment.
3. ERV Operation: When in Cooling mode AND the conditions are NOT OK for economizing - the ERV terminal will be energized. In the Heating mode the ERV terminal will be energized when the OA is below the ERV OAT set point in the set point menu.

Checkout Tests

Use the Checkout menu (see Table 11) to test the damper operation and any configured outputs. Only items that are configured are shown in the Checkout menu.

NOTE: See User Interface for information about menu navigation and use of the keypad.

To perform a Checkout test:

1. Scroll to the desired test in the Checkout menu using the ▲ and ▼ buttons.
2. Press the ↵ (Enter) button to select the item.
3. RUN? appears.
4. Press the ↵ (Enter) button to start the test.
5. The unit pauses and then displays IN PROGRESS.
6. When the test is complete, DONE appears.
7. When all desired parameters have been tested, press the ↑ (Menu up) button to end the test.

Checkout test can be performed at any time during the operation of the system as a test that the system is operable.

⚠ CAUTION

EQUIPMENT DAMAGE HAZARD

Failure to follow this caution may result in equipment damage. Be sure to allow enough time for compressor startup and shutdown between checkout tests so that you do not short-cycle the compressors.

W7220 Economizer Module Wiring

Use Tables 12 and 13 to locate the wiring terminals for the economizer module.

Table 12 — Economizer Module — Left Hand Terminal Blocks

LABEL	TYPE	DESCRIPTION
Top Left Terminal Block		
MAT MAT	20k NTC and COM	Mixed Air Temperature Sensor (Polarity insensitive connections)
OAT OAT	20k NTC and COM	Outdoor Air Temperature Sensor (Polarity insensitive connection)
S-BUS S-BUS	S-BUS (Sylk Bus)	Enthalpy Control Sensor (Polarity insensitive connection)
Bottom Left Terminal Block		
IAQ 2-10	2-10 vdc	Air Quality Sensor Input (e.g. CO ₂ sensor)
IAQ COM	COM	Air Quality Sensor Common
IAQ 24V	24 vac	Air Quality Sensor 24 vac Source
ACT 2-10	2-10 vdc	Damper Actuator Output (2-10 vdc)
ACT COM	COM	Damper Actuator Output Common
ACT 24V	24 vac	Damper Actuator 24 vac Source

Table 13 — Economizer Module — Right Hand Terminal Blocks

LABEL	TYPE	DESCRIPTION
Top Right Terminal Block		
	n/a	The first terminal is not used
AUX2 I	24 vac IN	Shut Down (SD) or Heat (W) Conventional only and Heat Pump Changeover (O/B) in Heat Pump mode.
OCC	24 vac IN	Occupied / Unoccupied Input
E - GND	E-GND	Earth Ground - System Required
EXH1	24 vac OUT	Exhaust Fan 1 Output
AUX1 O	24 vac OUT	Programmable: Exhaust fan 2 output or ERV or System alarm output
Bottom Right Terminal Block		
Y2-1	24 vac IN	Y2 in - Cooling Stage 2 Input from space thermostat
Y2-O	24 vac OUT	Y2 out - Cooling Stage 2 Output to stage 2 mechanical cooling
Y1-I	24 vac IN	Y1 in - Cooling Stage 2 Input from space thermostat
Y1-O	24 vac OUT	Y1 out - Cooling Stage 2 Output to stage 2 mechanical cooling
C	COM	24 vac Common
R	24 vac	24 vac Power (Hot)

TIME-OUT AND SCREEN SAVER

When no buttons have been pressed for 10 minutes, the LCD displays a screen saver, which cycles through the Status items. Each Status item displays in turn and cycles to the next item after 5 seconds.

START-UP AND OPERATION

Cooling with EconoMiSer® X

For Occupied mode operation of EconoMiSer X system, there must be a 24-v signal at terminals R and OCC (provided through PL6-3 from the unit's IFC coil). Removing the signal at OCC places the EconoMiSer X control in Unoccupied mode. See Table 14 for Damper Position Control.

During Occupied mode operation, indoor fan operation will be accompanied by economizer dampers moving to Minimum Position setpoint for ventilation. If indoor fan is off, dampers will close. During Unoccupied mode operation, dampers will remain closed unless a Cooling (by free cooling) or DCV demand is received.

When free cooling using outside air is not available, the unit cooling sequence will be controlled directly by the space thermostat. Outside air damper position will be closed or Minimum Position as determined by Occupancy mode and fan signal.

When free cooling is available as determined by the appropriate changeover command (dry bulb, outdoor enthalpy, differential dry bulb or differential enthalpy), a call for cooling (Y1 closes at the thermostat) will cause the economizer control to modulate the dampers open and closed to maintain the unit mixed air temperature. Default mixed air temperature is 53°F, with a range of 38°F to 70°F. Compressor will not run.

Should 100% outside air not be capable of satisfying the space temperature, space temperature will rise until Y2 is called for. The economizer control will call for compressor operation. Dampers will modulate to maintain MAT at set point concurrent with Compressor 1 operation. The "Low T Lock" setting (default 32°F) will lock out compressor operation when outside air temperature is below setpoint.

Table 14 — Damper Position Control, 2-Speed Fan Motor, Economizer Cooling Not Available

INPUT	VOLTAGE				
	OCC	0 - V	24 - V	24 - V	24 - V
Y1	0 - V	0 - V	24 - V	24 - V	0 - V
Y2	0 - V	0 - V	0 - V	24 - V	0 - V
W1	0 - V	0 - V	0 - V	0 - V	24 - V
SUPPLY FAN MOTOR SPEED	OFF	LOW	LOW	HIGH	HIGH
DAMPER POSITION					
NO CO ₂ SENSOR	CLOSED	MIN POS-L	MIN POS-L	MIN POS-H	MIN POS-H
W/ CO ₂ SENSOR	CLOSED	FROM VENTMIN L TO VENTMAX L	FROM VENTMIN L TO VENTMAX L	FROM VENTMIN H TO VENTMAX H	FROM VENTMIN H TO VENTMAX H

When space temperature demand is satisfied (thermostat Y1 opens), the dampers will return to Minimum Damper position if indoor fan is running or fully closed if fan is off.

If accessory power exhaust is installed, the power exhaust fan motors will be energized by the economizer control as the dampers open above the EXH1 SET setpoint and will be de-energized as the dampers close below the EXH1 SET setpoint. (For single speed unit.)

Damper movement from full closed to full open (or vice versa) will take between 1½ and 2½ minutes.

Heating with EconoMiSer® X

During Occupied mode operation, indoor fan operation will be accompanied by economizer dampers moving to Minimum Position setpoint for ventilation. If indoor fan is off, dampers will close. During Unoccupied mode operation, dampers will remain closed unless a DCV demand is received.

When the room temperature calls for heat (W1 closes), the heating controls are energized.

TROUBLESHOOTING

For a list of common operating issues and concerns, see Table 15.

Power Loss (Outage or Brownout)

All setpoints and advanced settings are restored after any power loss or interruption, as all settings are stored in the economizer controller's non-volatile flash memory.

NOTE: If power goes below 18 Vac, the W7220 module assumes a power loss and the 5-minute power-up delay will become functional when power returns above 18 vac.

Alarms

The economizer module provides alarm messages that display on the 2-line LCD.

NOTE: Upon power up, the module waits several seconds before checking for alarms. This allows time for all the configured devices (e.g. sensors, actuator) to become operational.

If one or more alarms are present and there has been no keypad activity for at least 5 minutes, the Alarms menu displays and cycles through the active alarms.

The Alarms menu can be navigated at any time. See Table 11 for the Alarms menu.

CLEARING ALARMS

Once the alarm has been identified and the cause has been removed (e.g. replaced faulty sensor). They can be cleared from the display.

To clear an alarm, perform the following:

1. Navigate to the desired alarm.
2. Press the \leftarrow (Enter) button.
3. ERASE? displays.
4. Press the \leftarrow (Enter) button.
5. ALARM ERASED displays.
6. Press the \uparrow (Menu Up/Exit) button to complete the action and return to the previous menu.

NOTE: If the alarm still exists after you clear it, it is redisplayed within 5 seconds.

Table 15 — Operating Issues and Concerns

ISSUE OR CONCERN	POSSIBLE CAUSE AND REMEDY
My outdoor temperature reading on the STATUS menu is not accurate	Check the sensor wiring: <ul style="list-style-type: none"> • Enthalpy sensors are to be wired to the S-Bus terminals. • Temperature sensors are to be wired to the OAT and MAT terminals.
If my enthalpy sensor drifts in accuracy over time, can I recalibrate it?	The sensor is not able to be re-calibrated in the field. However, there is a menu item under the ADVANCED menu to input a limited offset in temperature and humidity for each sensor that is connected to the economizer.
Can I go back to factory defaults and start over?	Under the SYSTEM SETUP menu, you can change the set points to the factory defaults.
Will I be able to see the LCD screen when it is in the unit?	The LCD screen has a backlight that is always illuminated.
What is a good set point for the Mixed Air Temperature (MAT)?	The Mixed Air Temperature is the temperature of air to supply to the space. In a commercial building, this is between 50°F and 55°F (10°C and 13°C). Mixed air is the combination of return air and outdoor air.
I am using enthalpy sensors. Why did the control ask me to input a dry bulb changeover temperature?	If the humidity sensor in the enthalpy sensors fails, the backup algorithm in the control is to default to the temperature sensor in the enthalpy sensor.
In checkout, the outdoor damper closes when I command it to open.	Check the actuator linkage or rotation. In the CHECKOUT mode, the outdoor damper should drive open or closed with the return air damper having the opposite effect.
How do I set my minimum position when using a CO ₂ sensor?	The minimum position is set using the VENTMIN and VENTMAX setup in the SETPOINTS menu. VENTMIN is the minimum ventilation required when using an occupancy sensor and VENTMAX is the minimum ventilation when not using an occupancy sensor for Demand Control Ventilation. The VENTMAX position is set the same as with the potentiometer on the analog economizers and is the output voltage to the damper actuator. The range is 2 vdc closed OA damper and 10 vdc open OA damper.
What if my damper does not go completely closed in the checkout operation?	Check the damper linkage or hub to make sure the damper is able to close completely.
How do I set the OCC?	There are two settings for the OCC setting: INPUT and ALWAYS. INPUT is from the space thermostat, if it has an occupancy output. ALWAYS is the unit in the occupied mode, if the economizer is powered (fan on).
Does the economizer save my program values if the unit loses power?	Yes, once the changes are stored in the controller they will be stored until they are changed by the operator.
If the unit is left in checkout, how long will the unit stay in checkout mode without input?	The unit will remain in checkout for 10 minutes, then return to normal operation.

