

50ES-A, 50EZ-A, 50VG-A, 50VL-A, B, C,
50VR-A, C, 50VT-A, B, C
604D--A, 607C--A, B, C, 607E--A, C,
704D--A, 707C--A, B, C, 707E--A
PA3G--A, PH3G--A, PA4G, PH4G
PAD3, PHD3, PAD4, PHD4, WPA4, WPH4,
PAR5, PHR5

SMALL PACKAGED PRODUCTS
Electric Heaters 5-20kW
60 Hz Product

Installation Instructions

NOTE: Read the entire instruction manual before starting the installation.

NOTE: Installation Instructions include Single and Dual point connection instructions separately.

SAFETY CONSIDERATIONS

Installation and servicing of this equipment can be hazardous due to mechanical and electrical components. Only trained and qualified personnel should install, repair, or service this equipment. Untrained personnel can perform basic maintenance functions such as cleaning and replacing air filters. All other operations must be performed by trained service personnel. When working on this equipment, observe precautions in the literature, on tags, and on labels attached to or shipped with the unit and other safety precautions that may apply.

Follow all safety codes. Installation must be in compliance with local and national building codes. Wear safety glasses, protective clothing, and work gloves. Have fire extinguisher available. Read these instructions thoroughly and follow all warnings or cautions included in literature and attached to the unit. Consult local building codes, the current editions of the National Electrical Code (NEC) NFPA 70.

In Canada refer to the current editions of the Canadian Electrical Code CSA C22.1.

Recognize safety information. This is the safety-alert symbol . When you see this symbol on the unit and in instructions or manuals, be alert to the potential for personal injury. Understand these signal words; DANGER, WARNING, and CAUTION. These words are used with the safety-alert symbol. DANGER identifies the most serious hazards which **will** result in severe personal injury or death. WARNING signifies hazards which **could** result in personal injury or death. CAUTION is used to identify unsafe practices which **may** result in minor personal injury or product and property damage. NOTE is used to highlight suggestions which **will** result in enhanced installation, reliability, or operation.

Follow all safety codes. Wear safety glasses and work gloves. Have a fire extinguisher available.

Before proceeding with heater installation, inspect thoroughly for shipping damage. Notify shipper immediately if any damage is found. Clean all dirt, dust and moisture from heater package. Check for proper clearances of live parts, between phases and to ground. Make sure that all required barriers are in place. Check conductors run in multiple to insure that they are properly wired. Refer to unit installation instructions for complete unit installation details. The maximum duct static for safe electric heater operation is shown in Table 1.

WARNING

ELECTRICAL SHOCK HAZARD

Failure to follow this warning could result in personal injury or death.

Before performing installation, service or maintenance operations on this system, turn off all main power to system. There may be more than one disconnect switch. Turn off accessory heater power switch if applicable. Lockout and tag switch with a suitable warning label.

CAUTION

CUT HAZARD

Failure to follow this caution may result in personal injury.

Sheet metal parts may have sharp edges or burrs. Use care and wear appropriate clothing, safety glasses and gloves when handling parts.

DESCRIPTION AND USAGE

This electric heater series is engineered, designed and listed to be installed only in the models shown in Table 2. Before proceeding, verify the heater label for correct voltage and kW requirements.

PACKAGE CONTENTS

Electric Heater Package Contents

1. Heater assembly
2. UPC heater label
3. Installation instructions
4. Identification label
5. Schematic on lid door for all fused units
6. Schematic on sticker to be placed inside unit panel for non-fused units
7. Wire connectors (3)
8. Wire ties-6-in. (5)
9. Screws #10A (5)
10. Dual Point Warning Label
11. Dual Point Electrical Rating Label

INSTALLATION

SINGLE POINT HEATER INSTALLATION

NOTE: Thermostat used must be capable of energizing “G” (indoor fan) on a call for “W” (heating). If “G” is not energized system malfunction will occur.

1. Open all electrical disconnects and install lockout tag before beginning any installation or service work.
2. Check for proper equipment model number from list.
3. Verify that unit ductwork is installed per base unit instructions.
4. Remove unit electrical access panel (See Fig. 1).
5. Locate and remove the heater access cover plate inside unit access panel (See Fig. 3). Save screws.
6. Remove electric heater from the packaging.
7. Install heater, sliding assembly carefully through access hole. Ensure that mounting holes of heater align with mounting holes on the unit. Secure heater assembly with screws provided.
8. (FOR FUSED EHATERS ONLY) Install included fuse box on bottom of Electrical Access Area. Screw holes on fuse box will align with holes on basepan lip inside Electrical Access Area. Secure fuse box with screws.
9. Dress wires with wire ties provided.

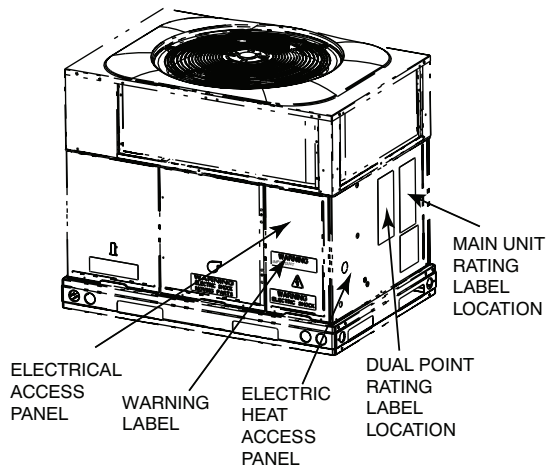

A13190

Fig. 1 - Unit Access Panel and Label Location

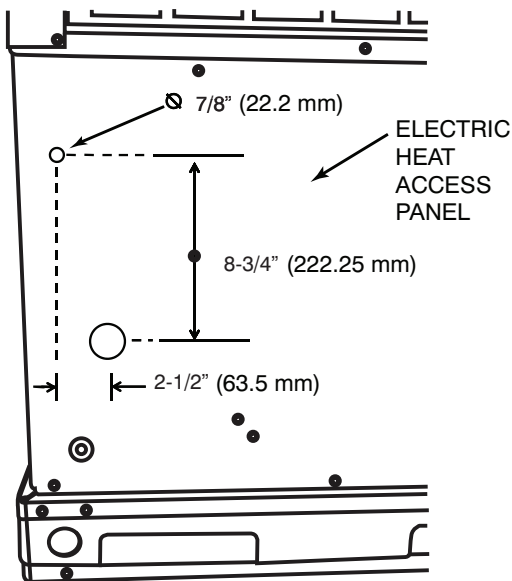

A10338

Fig. 2 - Second Power Line Access Hole Location

SINGLE POINT ELECTRICAL CONNECTION

NOTE: All electrical connections, wire sizes and type of conduit shall meet the National Electric Code (NEC) and state and local codes (or International Electric Code) as applicable.

NOTE: Use minimum 75°C copper wire only.

1. Make sure all disconnects are still open and tagged out as required previously.
2. Mark the main unit nameplate with an “X” for the electric heater size being installed. Refer to the electrical data marked with an “X” on the nameplate for wire and maximum over current protection sizing.

NOTE: On some outdoor models the accessory electric heater kit numbers have changed. Before installing heater kit, make sure kit is approved by referring to unit rating plate, and if used, unit label showing cross reference of approved heaters. Only use kits listed on unit rating plate or approved alternate.

3. Connect low voltage wires as shown in unit schematic diagrams found on the base unit installation instructions. These connections must be made in the 24v barrier section inside the unit panel (See Fig. 3).

NOTE: If the unit 24V wires do not have a matching receptacle, cut the 24V wires from the electric heater plug, strip the ends, and wire nut together to match the schematic connections. If the electric heater 24V wires do not have a matching plug, cut the 24V wires from the unit receptacle, strip the ends, and wire nut together to match the schematic connections.

4. Insert field power line through the electrical heater access panel hole (see Fig. 6 or 7) and connect to electric heater as shown in their respective wiring diagram. Fused electrical heaters field lines will be connected to the fuse block lugs (see Fig. 10) and non fused electric heater field lines will be connected to heater leads using wire nuts. Ground electrical equipment in the appropriate locations. Seal all openings to prevent air leaks.

IMPORTANT: Heaters with factory installed fuses may be installed on a branch circuit protected by either a fuse or circuit breaker. For all other heaters, the branch circuit must be protected by a fuse or circuit breaker supplied by others.

5. Connect stripped wires from heater to compressor contactor leads using supplied wire nuts according to their heater wiring diagram.

NOTE: Dress wires with wire ties provided. For fused heaters, use pre-mounted wire tires inside of fuse box cover to secure and strain relieve wires.

6. Separate all wires from incoming power leads.
7. Close electrical access panel.

DUAL POINT HEATER INSTALLATION

NOTE: Complete single point heater installation procedures before completing the follow steps.

1. Open all electrical disconnects and install lockout tag before beginning any installation or service work.
2. Remove electric access panel (see Fig. 1), check to make sure there is clearance on the inside of control box above the existing high voltage knockout. Using a knockout punch and die combination, make a 7/8-in. hole on the Electrical Heat access panel for second power circuit (see Fig. 2). A knockout punch and die combination or equivalent tool is required to make this hole. Other types of drill bits or standard hole saws are not acceptable.
3. Attach warning and rating labels in the selected location (see Fig. 1).
4. Mark the main unit nameplate with an “X” next to the accessory heater “none”. Mark the dual point rating label

installed at step 3 with an “X” for the electrical heater size being installed. Refer to the electrical data marked with an “X” on each nameplate for wire and maximum over current protection sizing.

5. Remove power line connection from heater to unit contactor and compressor (see Fig. 4 and Fig. 5). These are the stripped end wires black and yellow, with opened ends.

DUAL POINT ELECTRICAL CONNECTION

NOTE: All electrical connections, wire sizes and type of conduit shall meet the national Electric Code (NEC) and state and local codes (or International Electric Code) as applicable.

NOTE: Use a minimum 75°C copper wire only.

1. Make sure all disconnects are still open and tagged out as required previously.
2. Connect low voltage wires as shown in unit schematic diagrams found on base unit installation instructions. These connections must be made in the 24v barrier section inside the unit panel (see Fig. 3).

NOTE: If the unit 24V wires do not have a matching receptacle, cut the 24V wires from the electric heater plug, strip the ends, and wire nut together to match the schematic connections. If the electric heater 24V wires do not have a matching plug, cut the 24V wires from the unit receptacle, strip the ends, and wire nut together to match the schematic connections.

3. Insert first field power line through the electrical heater access panel bottom hole (see Fig. 8 or Fig. 9) and connect to electric heater as shown in their respective wiring diagram found on the heater accessory kit. Fused electrical heaters field lines will be connected to the fuse block lugs (see Fig. 10.) and non fused electric heater field lines will be connected to heater leads using wire nuts. Ground electrical equipment in the appropriate locations. Seal all openings to prevent air leaks.

IMPORTANT: Heaters with factory installed fuses may be installed on a branch circuit protected by either a fuse or circuit breaker. For all other heaters, the branch circuit must be protected by a fuse or circuit breaker supplied by others.

NOTE: Dress wires with wire ties provided. For fused heaters, use pre-mounted wire ties inside of fuse box cover to secure and strain relieve wires.

4. Insert second field power line through the electrical heater access panel top hole (see Fig. 8 or Fig. 9) and connect to unit contactor black and yellow leads using wire nuts. Ground electrical equipment in the appropriate locations.
5. Separate all wires from incoming power leads.
6. Close electrical access panel.

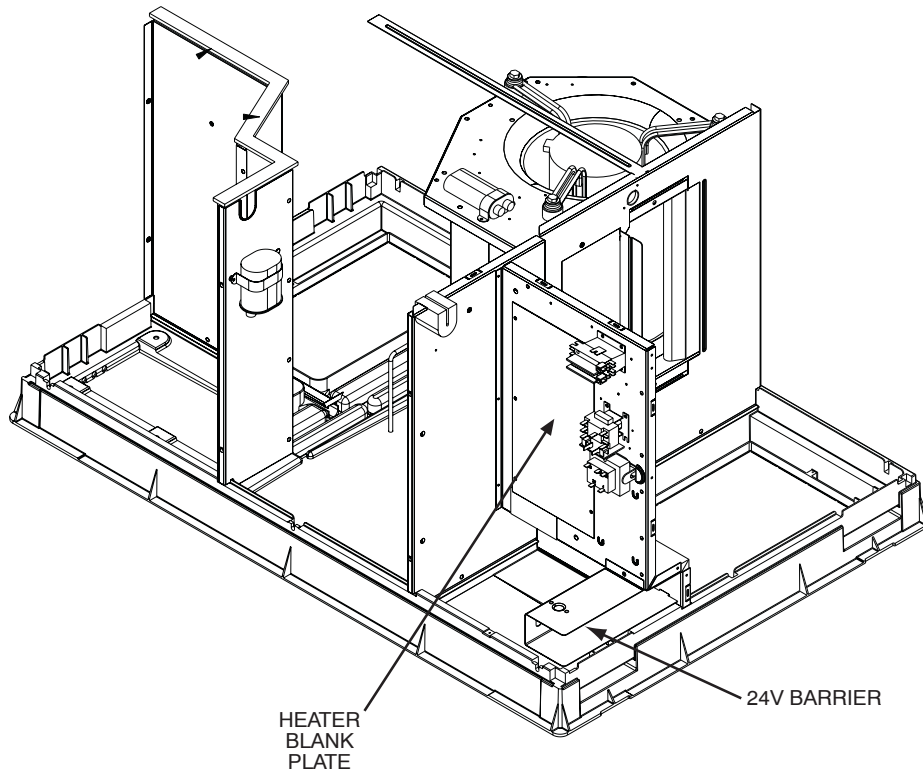

Fig. 3 - Heater Blank Plate Location

A06282

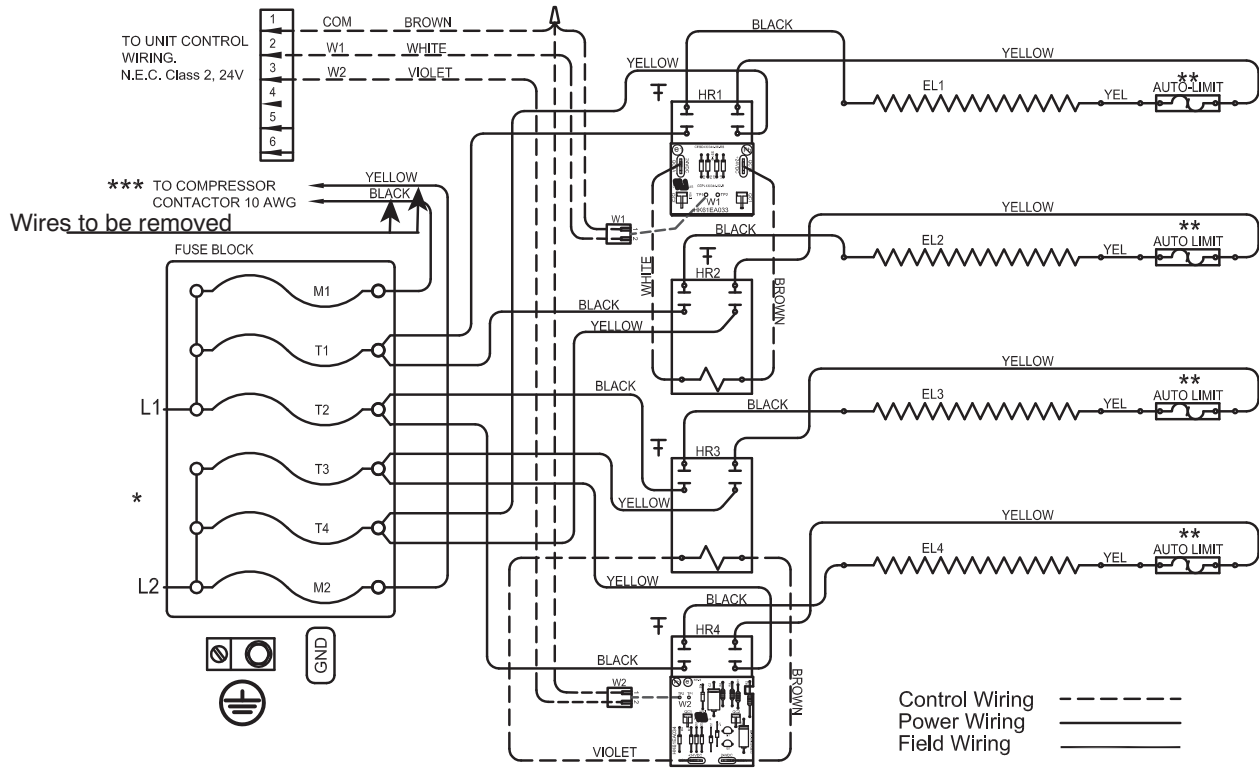

Fig. 4 - Wiring Diagram Example for Fused Heater

A14444

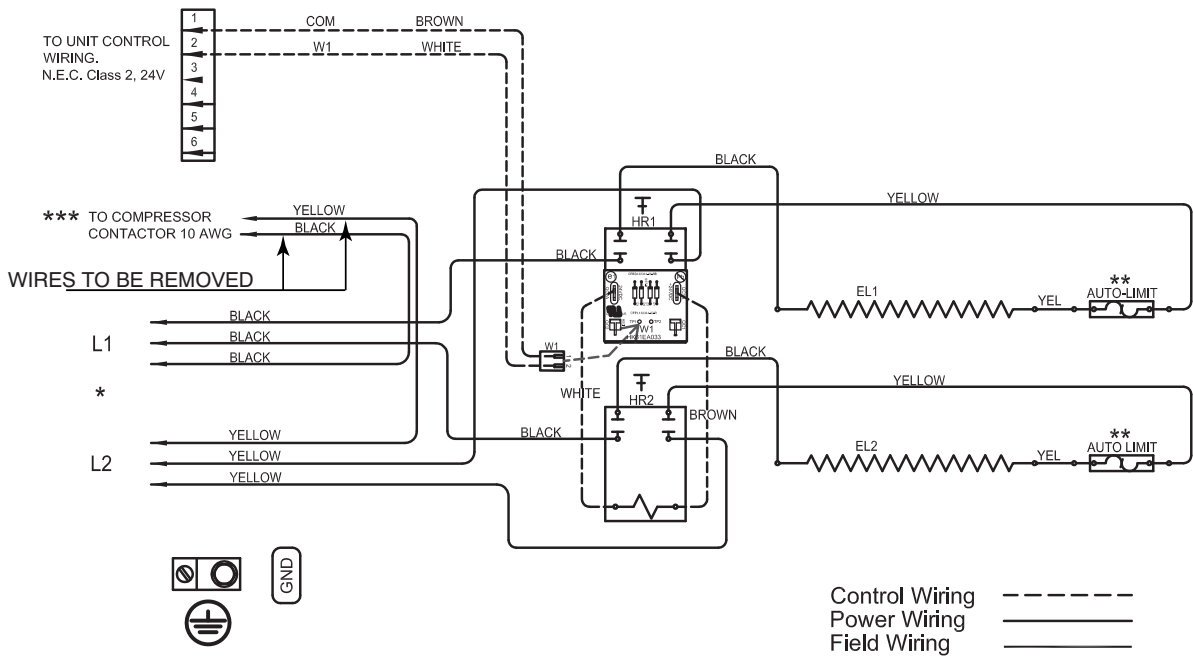

Fig. 5 - Wiring Diagram Example for Non-Fused Heater

A14445

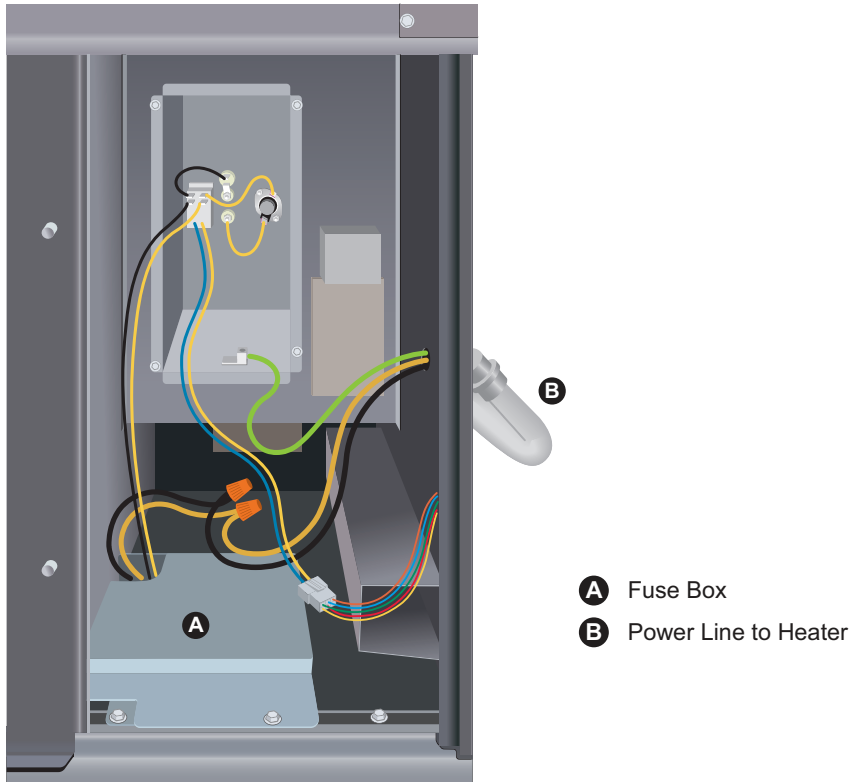

Fig. 6 - Single Point Connections for Fused Heater

A190249

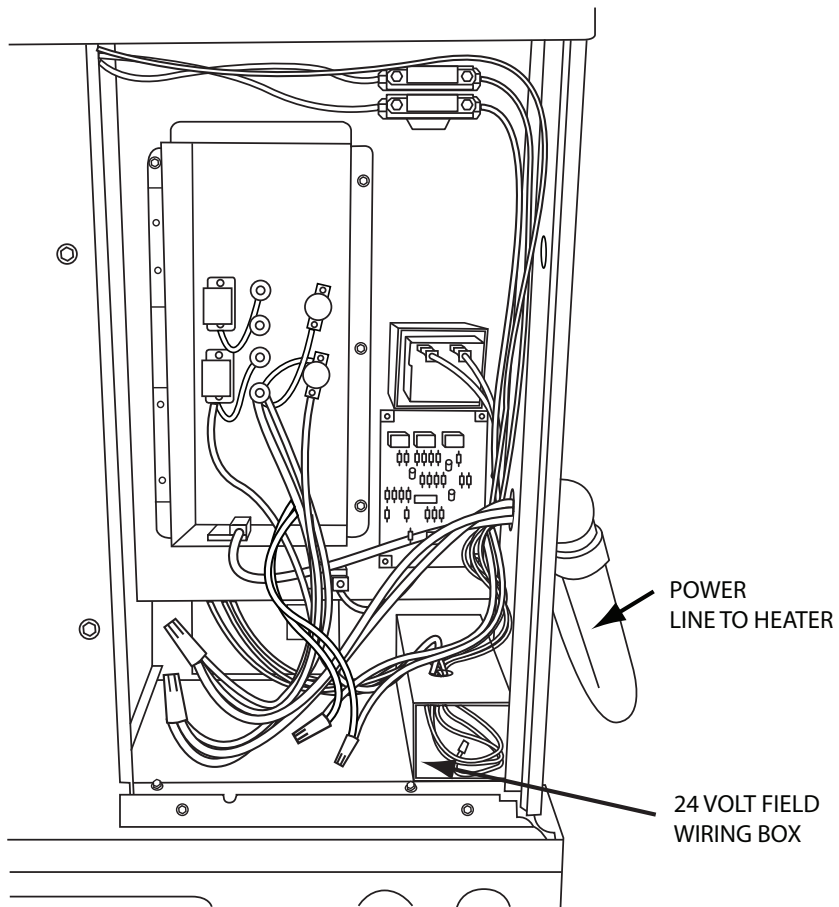

Fig. 7 - Single Point Connections for Non-Fused Heater

A10370

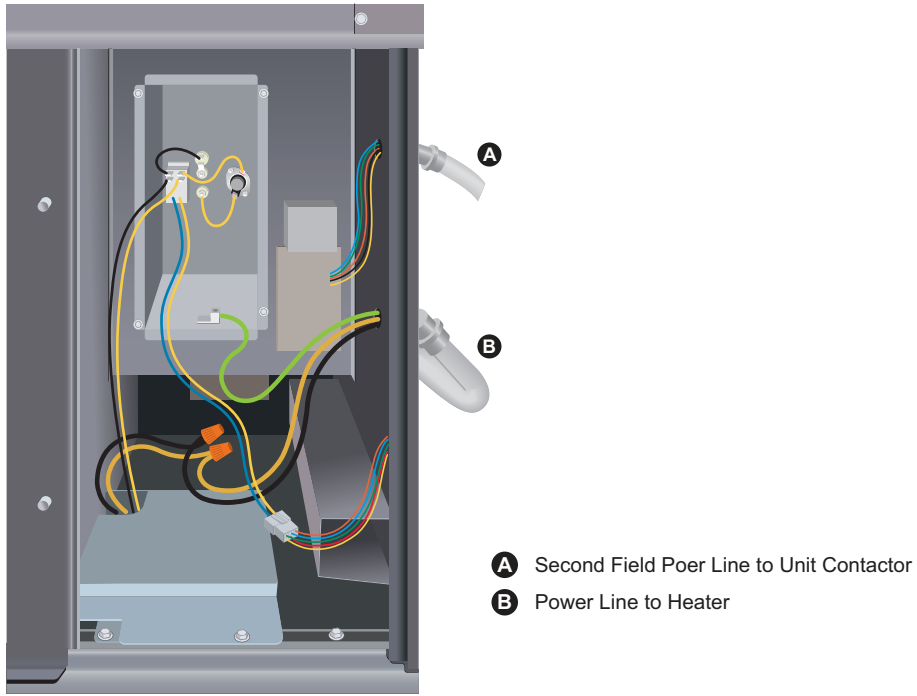

Fig. 8 - Dual Point Connections for Fused Heater

A190250

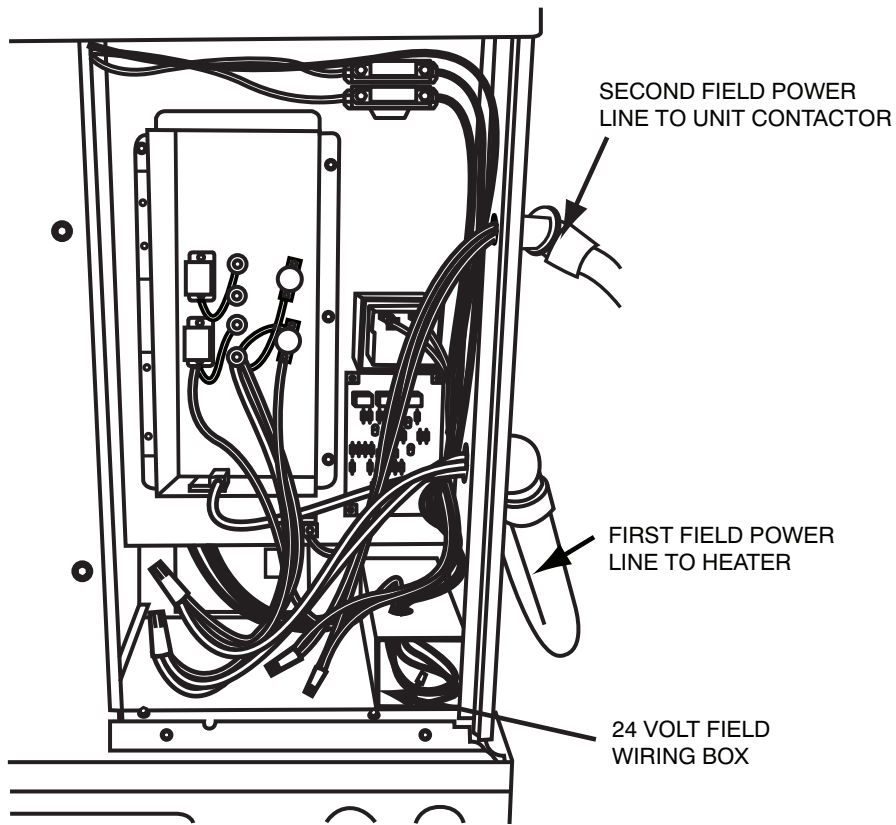

Fig. 9 - Dual Point Connection for Non-Fused Heater

A10340

START-UP

WARNING

ELECTRICAL SHOCK HAZARD

Failure to follow this warning could result in personal injury or death.

Before proceeding, verify that all wiring is correct per factory approved schematic. Notify factory immediately of any discrepancies.

NOTE: Heater Relay, Rectifier, Time Delay Boards 208/230 1 PH and 3 PH heaters only (does not include 460v). Each heater element is controlled by a 24VDC control relay. Each control relay is energized by a small rectifier board attached directly to relay coil terminals. When possible one rectifier board is used to control a second relay.

The rectifier board converts incoming 24v AC control signal to DC. Some heaters may have up to four relays. The second and/or third relay rectifier board may also have a time delay feature and a small jumper wire built into it. With the jumper uncut, the time delay is approximately 5 sec after the initial first stage. When jumper is cut at factory this provides an 8 sec delay.

NOTE: Refer to base unit installation instructions as required.

1. Check for loose terminal connections.
2. Check that all fuse and circuit breaker short circuit interrupting ratings are adequate.
3. Turn on unit and heater power.
4. Set thermostat to call for heat.
5. Check operation of heater.
6. Check that airflow across the heater is at or above the minimum recommended CFM requirement (See unit installation instructions). Adjust indoor blower heat speed as required. Check that duct system conforms to static pressure limits in Table 1.

NOTE: See Table 1 for Non-Export units (with -3, -5 or -6 as electrical option-see product data).

TROUBLESHOOTING

1. Fuses - Malfunction will interrupt power to the unit. Check for cause of failure, replace fuses.
2. Limit Switch - Malfunction prevents heating element(s) from being energized. Replace switch if malfunction occurs.
3. Contactor - Malfunction will not allow heater to energize. Replace faulty contactor. Do not attempt to replace coil or dress contacts.

**Table 1 – Maximum Duct Static Pressure for 60 Hz Units
(IN. W.C.) (pa)**

UNIT (60 HZ UNITS)	MAXIMUM STATIC PRESSURE UNIT SIZE					
	024	030	036	042	048	060
Heat Pump	.50 (125)	.50 (125)	.50 (125)	.50 (125)	.50 (125)	.50 (125)
Electric Cooling	.50 (125)	.50 (125)	.50 (125)	.50 (125)	.50 (125)	.50 (125)

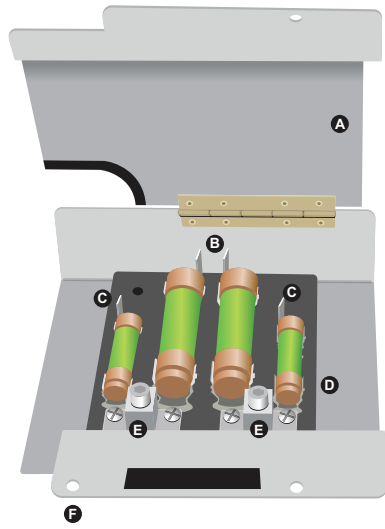

- A Fuse Box Lid (shown open)
- B Compressor Contactor Wire (Yellow and Black)
- C Connectors to the Heater Rectifier Board (Yellow and Black)
- D Heater Fuse Block
- E Field Wire Connections
- F Attach Box with 2 screws

Fig. 10 - Fused Heater Example Fuse Box

A190251

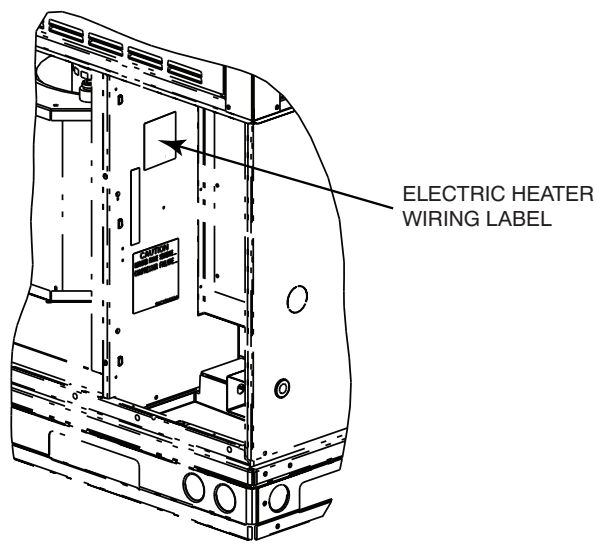

Fig. 11 - Schematic Location for Non-Fused Heater

A10384

Table 2 – Electric Heater Usage Chart—60 Hz Units

Single Stage PAC					50ES –A, 704D – –A, PA3G – –A, PAD3 (PAC)						50VL –A, B, C, 707C – –A, B, C, PA4G, PAD4, WPA4 (PAC)					
CPHEATER	kW	V	PH	Fuse	24	30	36	42	48	60	24	30	36	42	48	60
052	5	230	1	0	x	x	x	x	x	x	x	x	x	x	x	x
064	5	230	1	4	x	x	x	x	x	x	x	x	x	x	x	x
069	7.2	230	1	0	x	x	x	x	x	x	x	x	x	x	x	x
070	7.2	230	1	4	x	x	x	x	x	x	x	x	x	x	x	x
065	10	230	1	0	x	x	x	x			x	x	x	x		
050	10	230	1	4	x	x	x	x	x	x	x	x	x	x	x	x
051	15	230	1	4				x						x		
066	15	230	1	6				x	x	x				x	x	x
133	15	230	1	4		x	x					x	x			
053	20	230	1	4				x						x		
054	20	230	1	6				x	x	x				x	x	x
055	5	230	3	0			x	x	x	x			x	x	x	x
056	10	230	3	0			x	x	x	x			x	x	x	x
068	10	230	3	6			x	x	x	x			x	x	x	x
057	15	230	3	0			x	x	x	x			x	x	x	x
058	15	230	3	6			x	x	x	x			x	x	x	x
059	20	230	3	6				x	x	x				x	x	x
061	10	460	3	0			x	x	x	x			x	x	x	x
062	15	460	3	0			x	x	x	x			x	x	x	x
063	20	460	3	0				x	x	x				x	x	x

= base unit not offered

x = Approved combination

Dual Stage PAC					50VG –A, 707E – –A, PAR5 (PAC)					
CPHEATER	kW	V	PH	Fuse	24	30	36	42	48	60
052	5	230	1	0	x	x	x	x	x	x
064	5	230	1	4	x	x	x	x	x	x
069	7.2	230	1	0	x	x	x	x	x	x
070	7.2	230	1	4	x	x	x	x	x	x
065	10	230	1	0	x	x	x	x		
050	10	230	1	4	x	x	x	x	x	x
051	15	230	1	4			x	x		
066	15	230	1	6			x	x	x	x
133	15	230	1	4		x				
053	20	230	1	4				x		
054	20	230	1	6				x	x	x
055	5	230	3	0		x	x	x	x	x
056	10	230	3	0		x	x	x	x	x
068	10	230	3	6		x	x	x	x	x
057	15	230	3	0		x	x	x	x	x
058	15	230	3	6		x	x	x	x	x
059	20	230	3	6				x	x	x
061	10	460	3	0			x	x	x	x
062	15	460	3	0			x	x	x	x
063	20	460	3	0				x	x	x

= base unit not offered

x = Approved combination

CPHEATER

Table 2 — Electric Heater Usage Chart—60 Hz Units Continued

Single Stage HP					50EZ-A, 604D--A, PH3G--A, PHD3 (PHP)						50VT-A, B, C, 607C--A, B, C, PH4G, PHD4, WPH4 (PHP)					
CPHEATER	kW	V	PH	Fuse	24	30	36	42	48	60	24	30	36	42	48	60
052	5	230	1	0	x	x	x				x	x	x			
064	5	230	1	4	x	x	x	x	x	x	x	x	x	x	x	x
069	7.2	230	1	0												
070	7.2	230	1	4	x	x	x	x	x	x	x	x	x	x	x	x
065	10	230	1	0												
050	10	230	1	4	x	x	x	x	x	x	x	x	x	x	x	x
051	15	230	1	4												
066	15	230	1	6			x	x	x	x			x	x	x	x
133	15	230	1	4		x						x				
053	20	230	1	4												
054	20	230	1	6				x	x	x				x	x	x
055	5	230	3	0			x	x	x	x			x	x	x	x
056	10	230	3	0			x	x	x				x	x		
068	10	230	3	6			x	x	x	x			x	x	x	x
057	15	230	3	0												
058	15	230	3	6			x	x	x	x			x	x	x	x
059	20	230	3	6				x	x	x				x	x	x
061	10	460	3	0			x	x	x	x			x	x	x	x
062	15	460	3	0			x	x	x	x			x	x	x	x
063	20	460	3	0				x	x	x				x	x	x

 = base unit not offered

 = base unit not offered

x = Approved combination

CPHEATER

Dual Stage HP					50VR-A, C 607E--A, C (PHP)					
CPHEATER	kW	V	PH	Fuse	24	30	36	42	48	60
052	5	230	1	0	X	X	X			
064	5	230	1	4	X	X	X	X	X	X
069	7.2	230	1	0	X					
070	7.2	230	1	4	X	X	X	X	X	X
065	10	230	1	0						
050	10	230	1	4	X	X	X	X	X	X
051	15	230	1	4						
066	15	230	1	6			X	X	X	X
133	15	230	1	4		X				
053	20	230	1	4						
054	20	230	1	6				X	X	X
055	5	230	3	0		x	x	x	x	x
056	10	230	3	0		x	x	x	x	
068	10	230	3	6		x	x	x	x	x
058	15	230	3	6		x	x	x	x	x
059	20	230	3	6				x	x	x
061	10	460	3	0			x	x	x	x
062	15	460	3	0			x	x	x	x
063	20	460	3	0				x	x	x

x = Approved combination

Table 3 – Electric Heater Part Number Information

CPHEATER	Diagram	kW @			V / PH / Hz			Amps			Power Connection		No. Stages	24v Unit Control Wiring			KW Staging	
		208	240	480	V	Phase	Hz	208v	240v	480v	Pig Tail	Fuse Block		Comm (Brown)	W1 (White)	W2 (Violet)	Stage 1	Stage 2
052B00	111003365	3.80	5		208/230	1	60	18.10	20.80		x		x			5kw		
064B00	111003366	3.80	5		208/230	1	60	18.10	20.80			x				5kw		
069B00	111003367	5.40	7.20		208/230	1	60	25.90	30		x					7.2kw		
070B00	111003368	5.40	7.20		208/230	1	60	25.90	30			x				7.2kw		
065B00	111003369	7.50	10		208/230	1	60	36.10	41.70		x					10kw		
050B00	111003370	7.50	10		208/230	1	60	36.10	41.70			x				10kw		
051B00	111003371	11.30	15		208/230	1	60	54.20	62.50			x				5kw	10kw	
066B00	111003372	11.30	15		208/230	1	60	54.20	62.50			x				5kw	10kw	
133B00	111003373	11.30	15	-	208/230	1	60	54.20	62.50	-		x				5kw	10kw	
053B00	111003374	15	20		208/230	1	60	72.20	83.30			x				10kw	10kw	
054B00	111003375	15	20		208/230	1	60	72.20	83.30			x				10kw	10kw	
055B00	111003376	3.80	5		208/230	3	60	10.40	12		x					5kw		
056B00	111003377	7.50	10		208/230	3	60	20.80	24.10		x					10kw		
068B00	111003378	7.50	10		208/230	3	60	20.80	24.10			x				10kw		
057B00	111003379	11.30	15		208/230	3	60	31.30	36.10		x					15kw		
058B00	111003380	11.30	15		208/230	3	60	31.30	36.10			x				15kw		
059B00	111003381	14.90	19.90		208/230	3	60	41.40	47.90			x				20kw		
061B00	111003382			10	460	3	60			12	x					10kw		
062B00	111003383			15	460	3	60			18	x					15kw		
063B00	111003384			20	460	3	60			24.10	x					20kw		

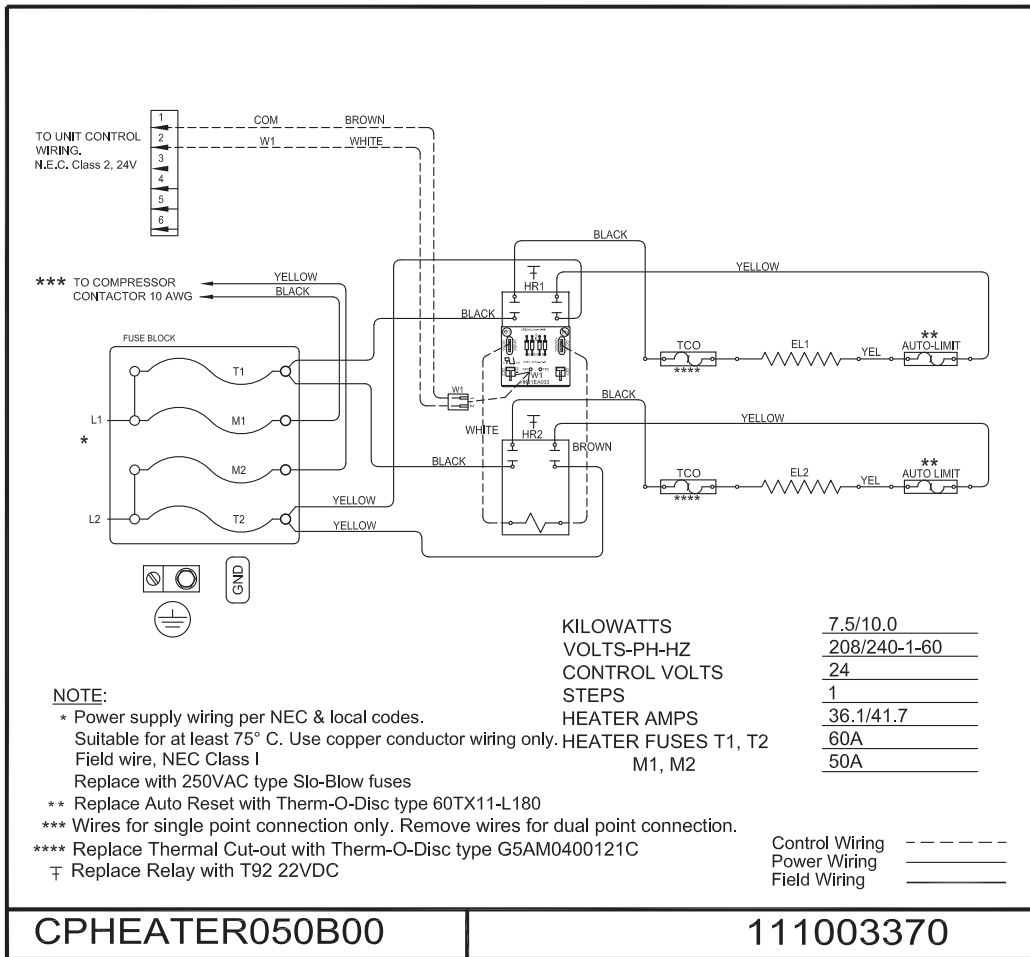

Fig. 12 - CPHEATER050B00 Wiring Diagram

A190181

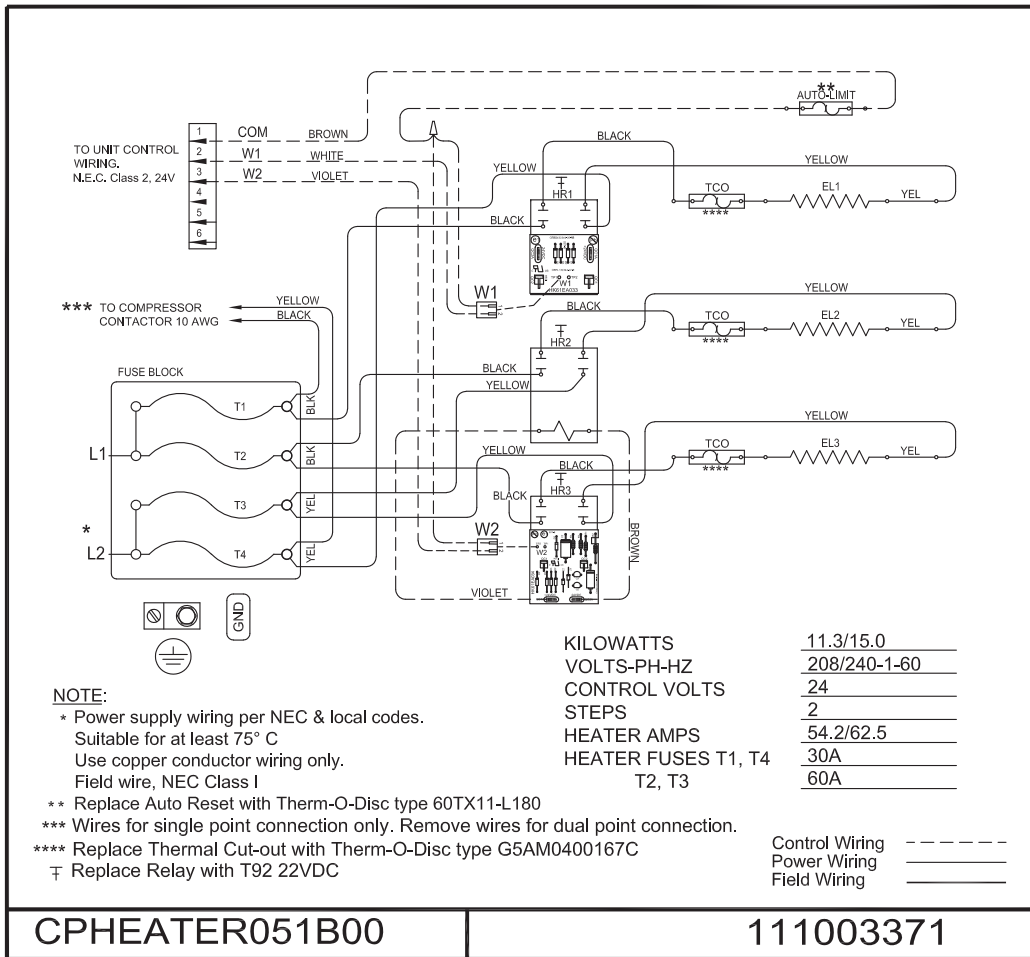

Fig. 13 - CPHEATER051B00 Wiring Diagram

A190182

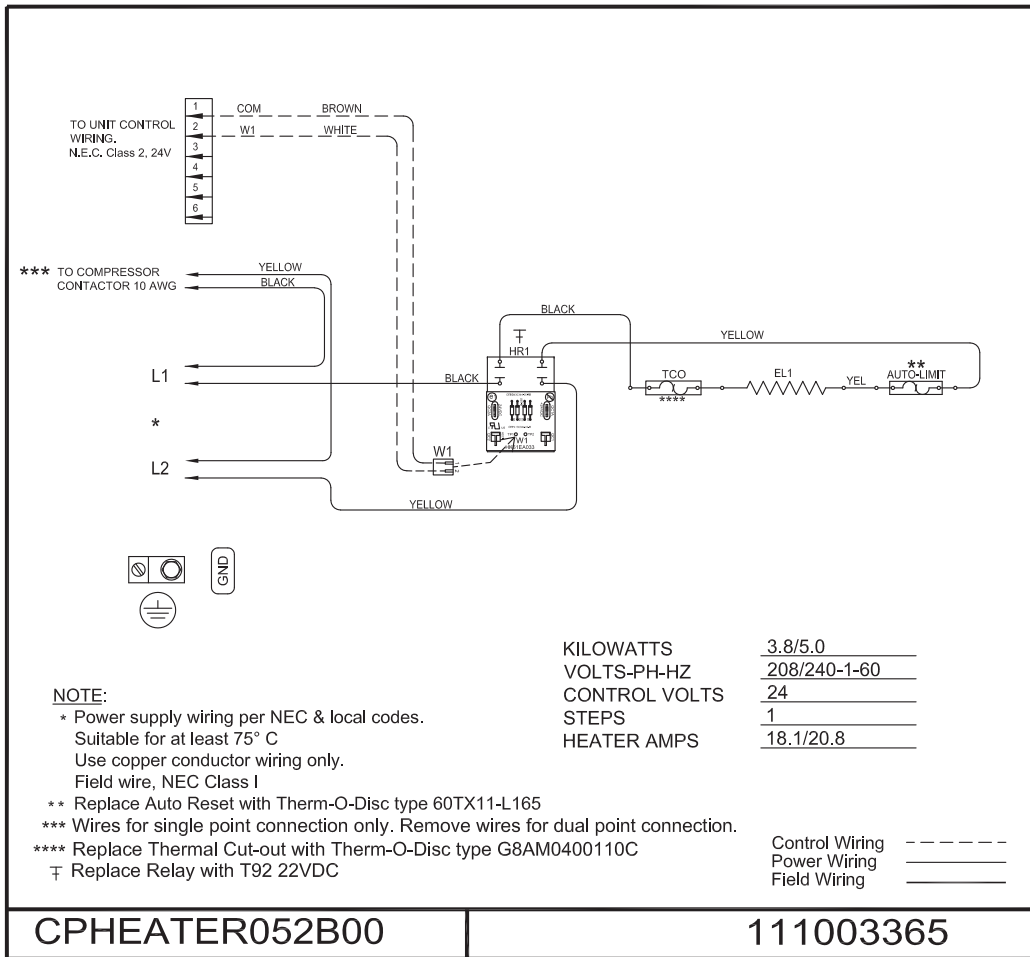

Fig. 14 - CPHEATER052B00 Wiring Diagram

A190176

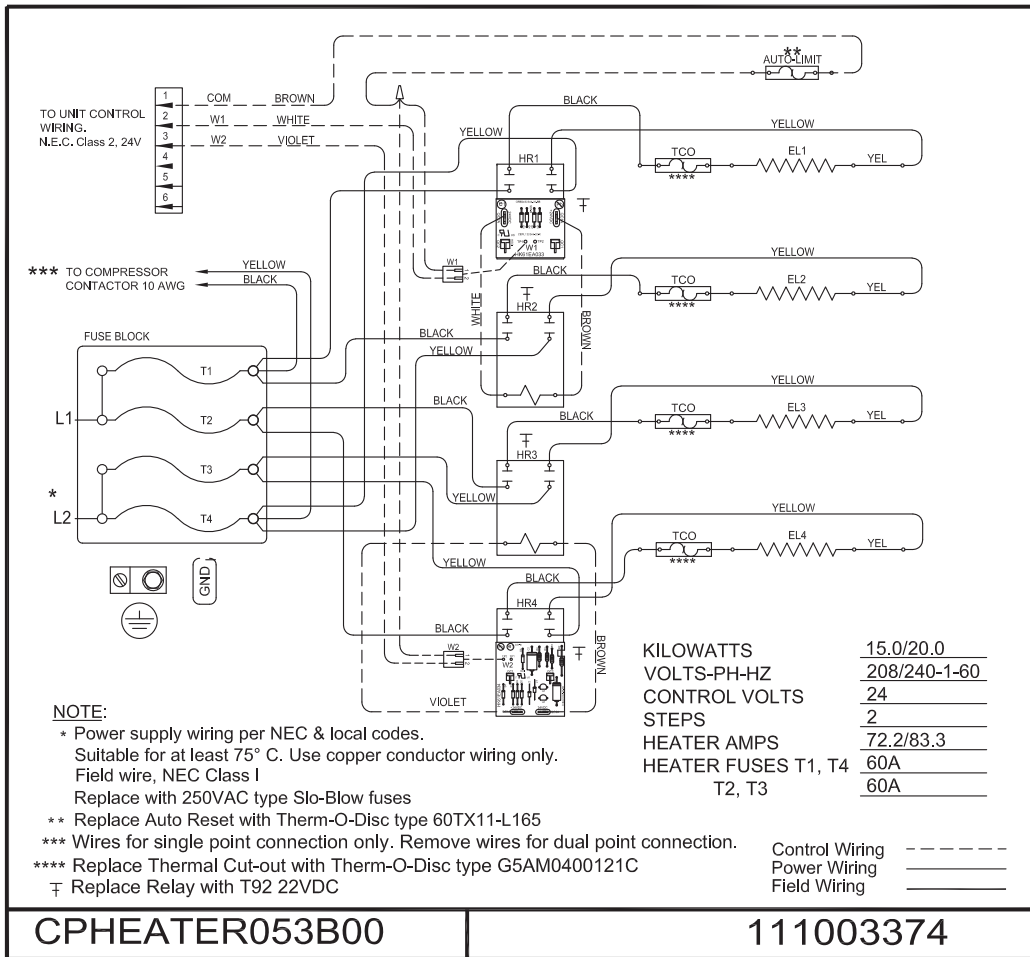

Fig. 15 - CPHEATER053B00 Wiring Diagram

A190185

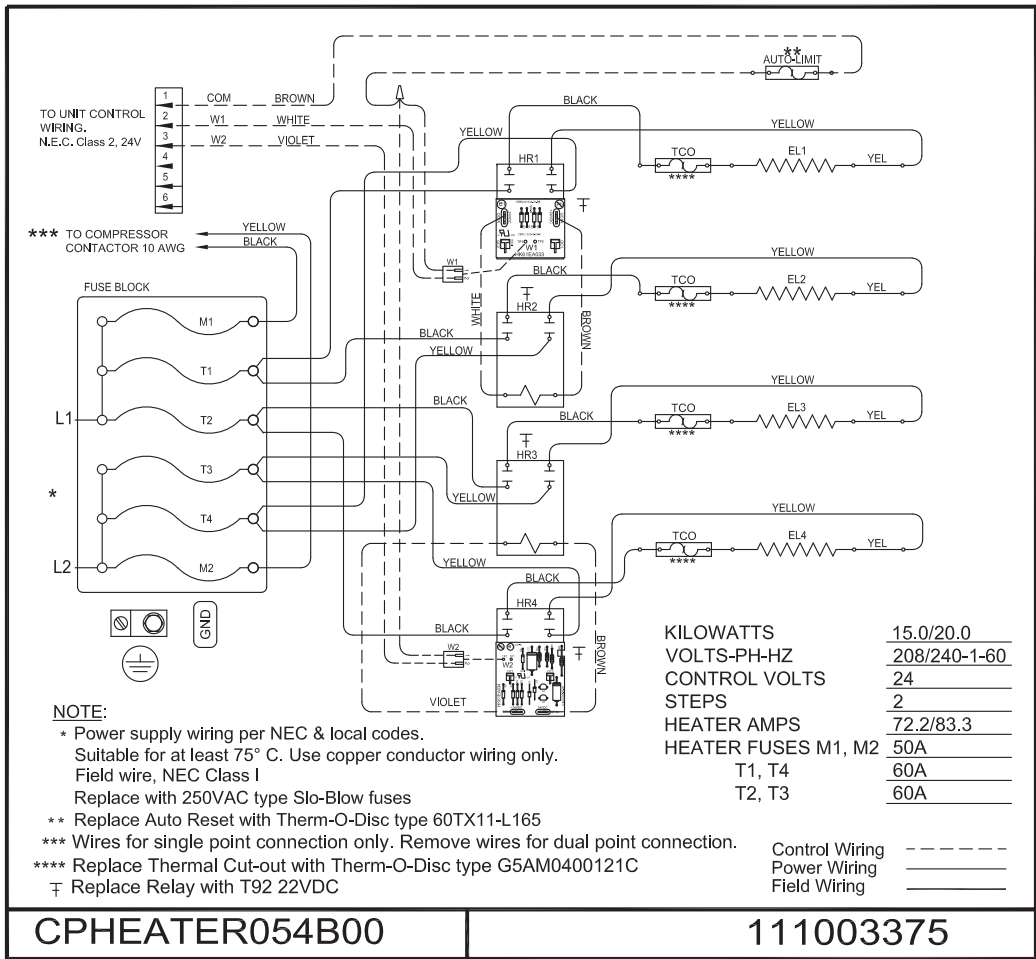

Fig. 16 - CPHEATER054B00 Wiring Diagram

A190186

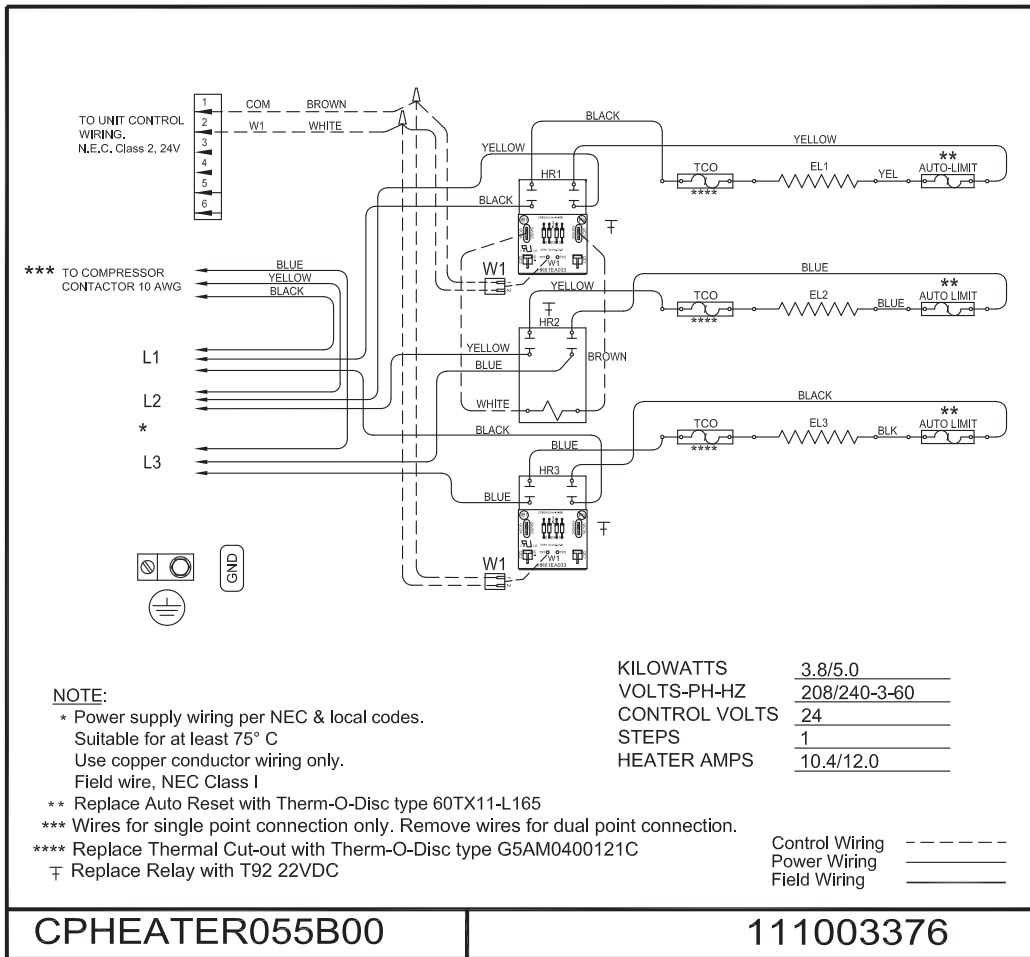

Fig. 17 - CPHEATER055B00 Wiring Diagram

A190187

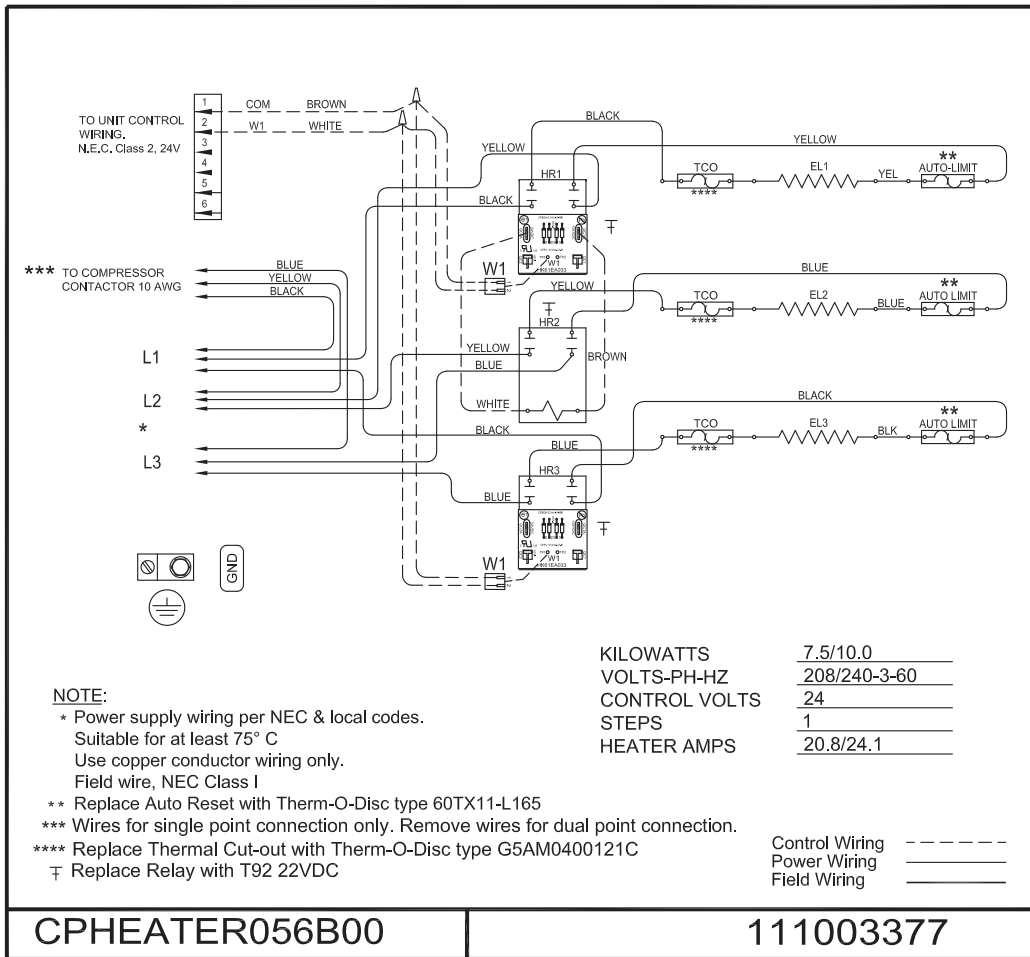

Fig. 18 - CPHEATER056B00 Wiring Diagram

A190188

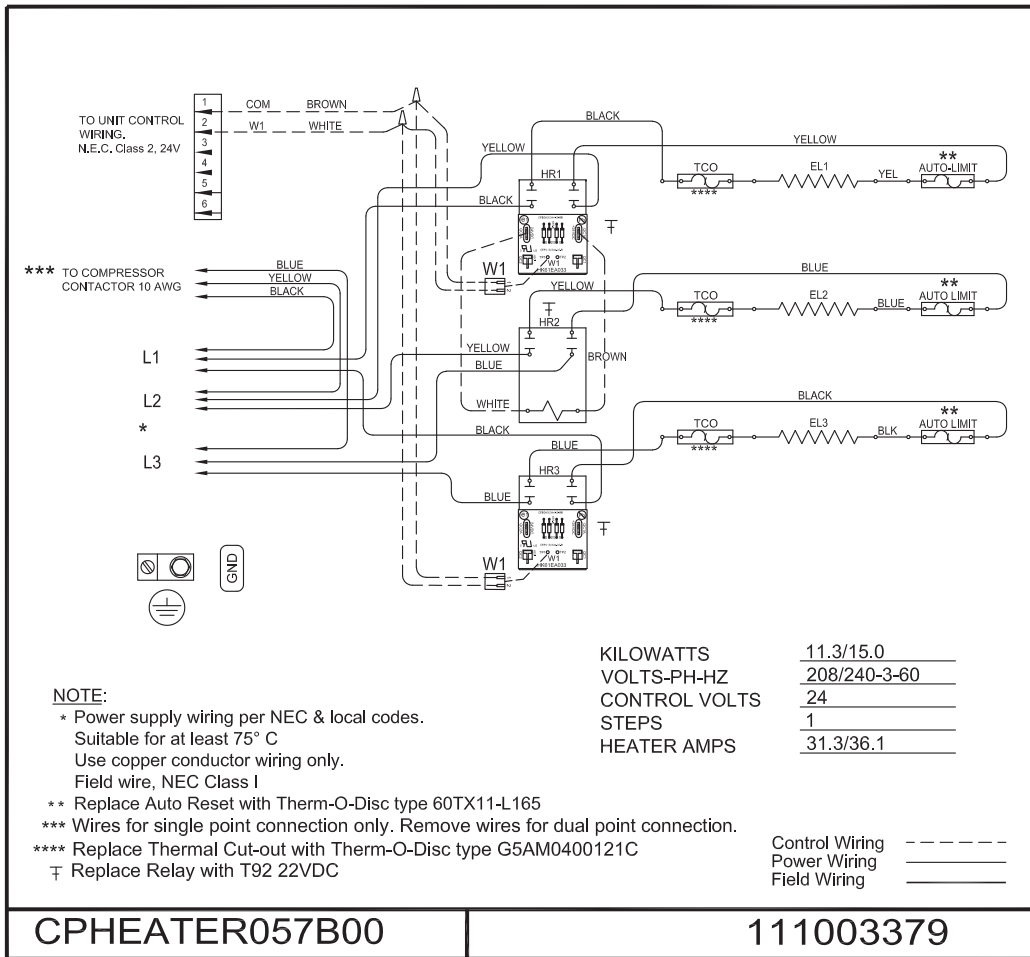

Fig. 19 - CPHEATER057B00 Wiring Diagram

A190190

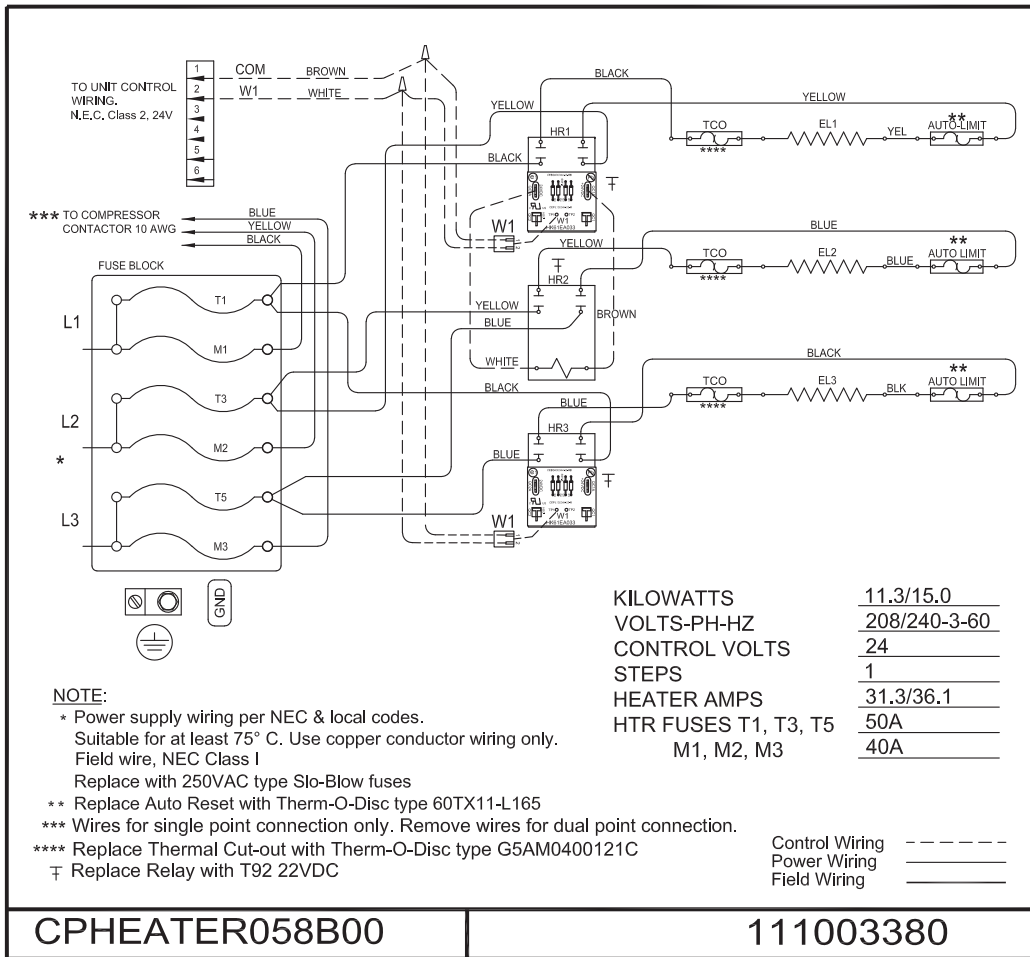

Fig. 20 - CPHEATER058B00 Wiring Diagram

A190191

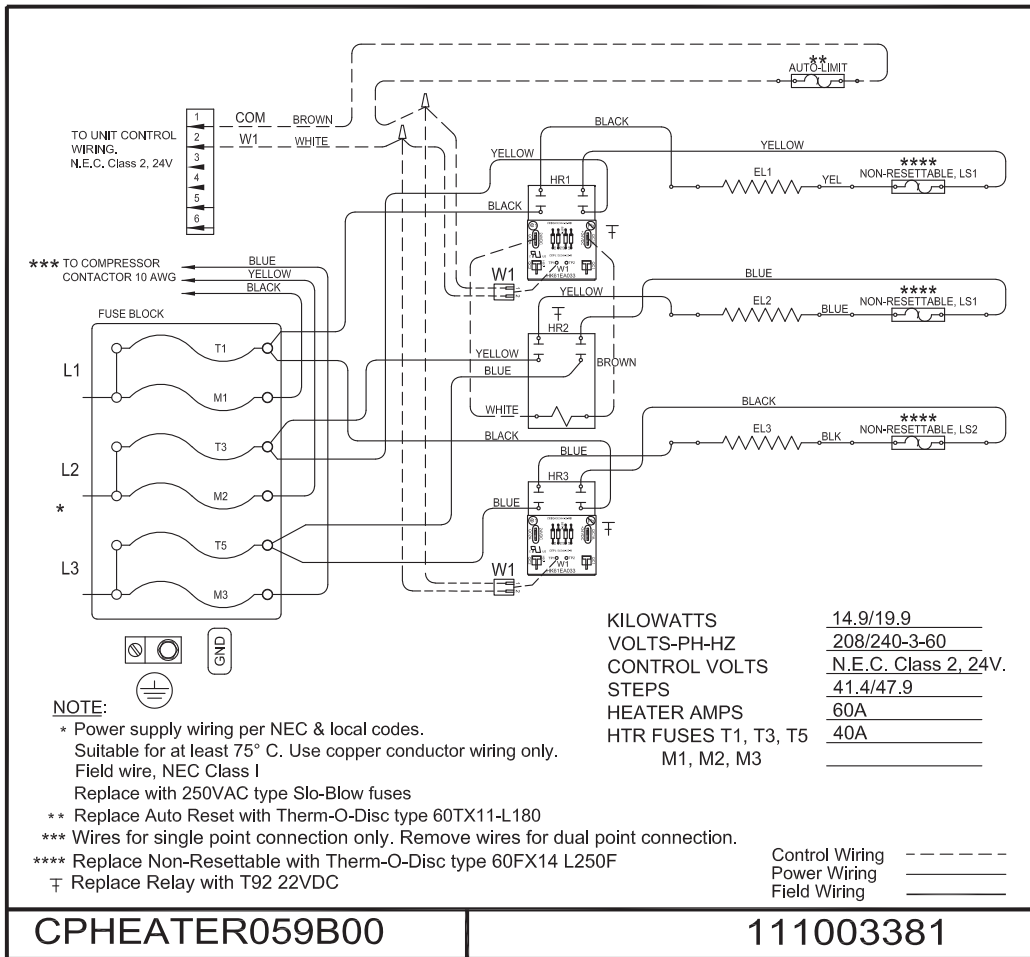

Fig. 21 - CPHEATER059B00 Wiring Diagram

A190192

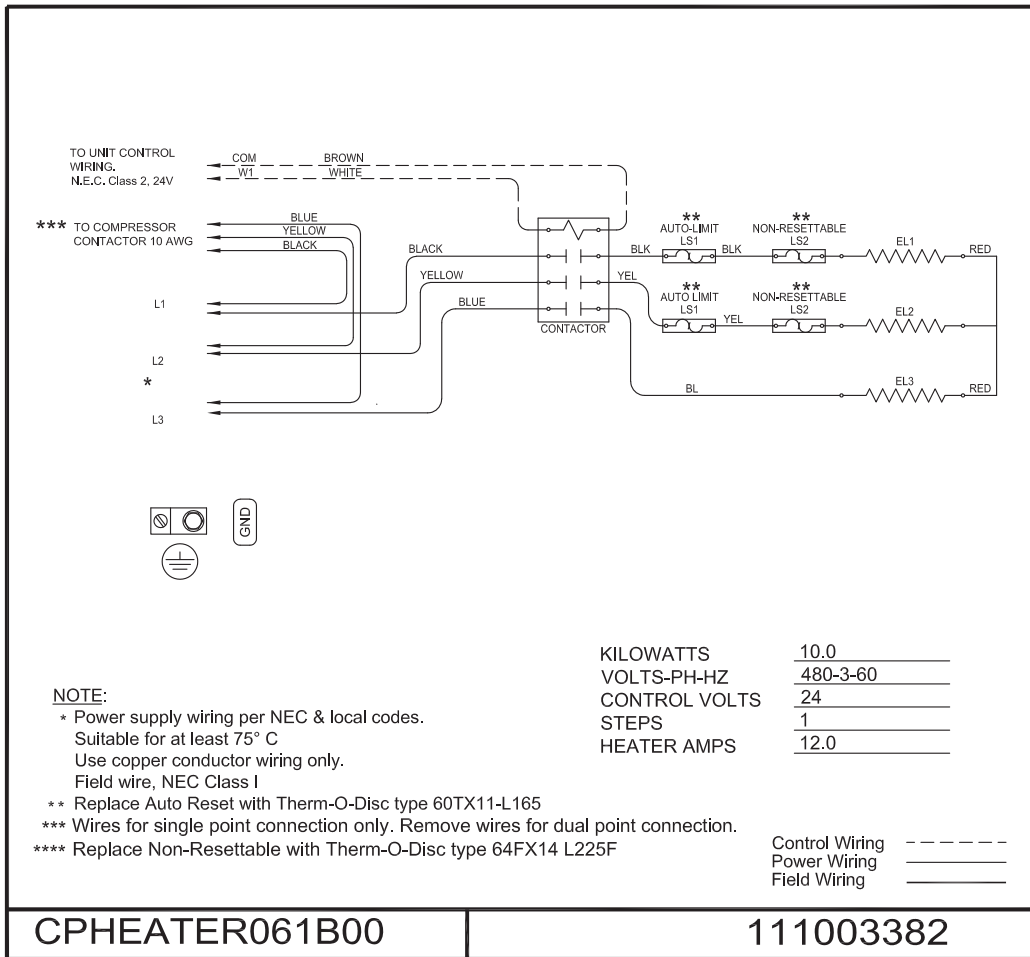

Fig. 22 - CPHEATER061B00 Wiring Diagram

A190193

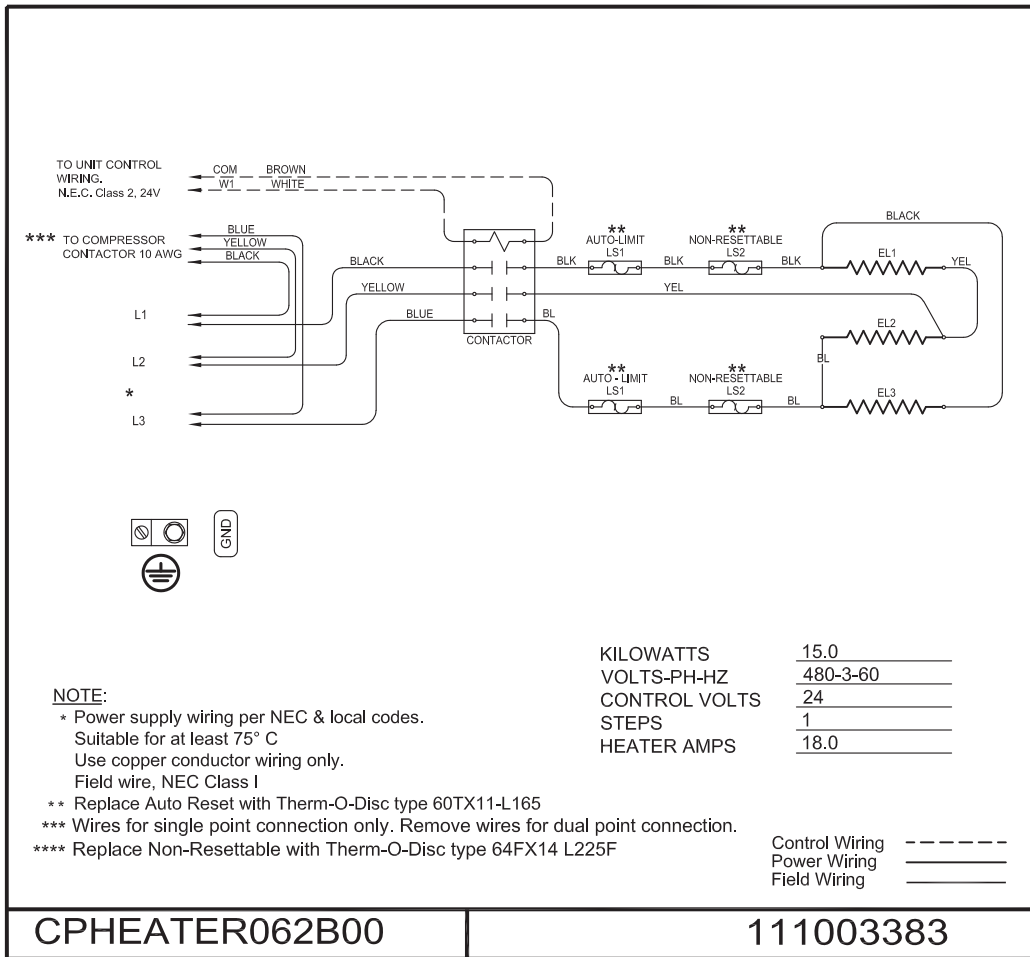

Fig. 23 - CPHEATER062B00 Wiring Diagram

A190194

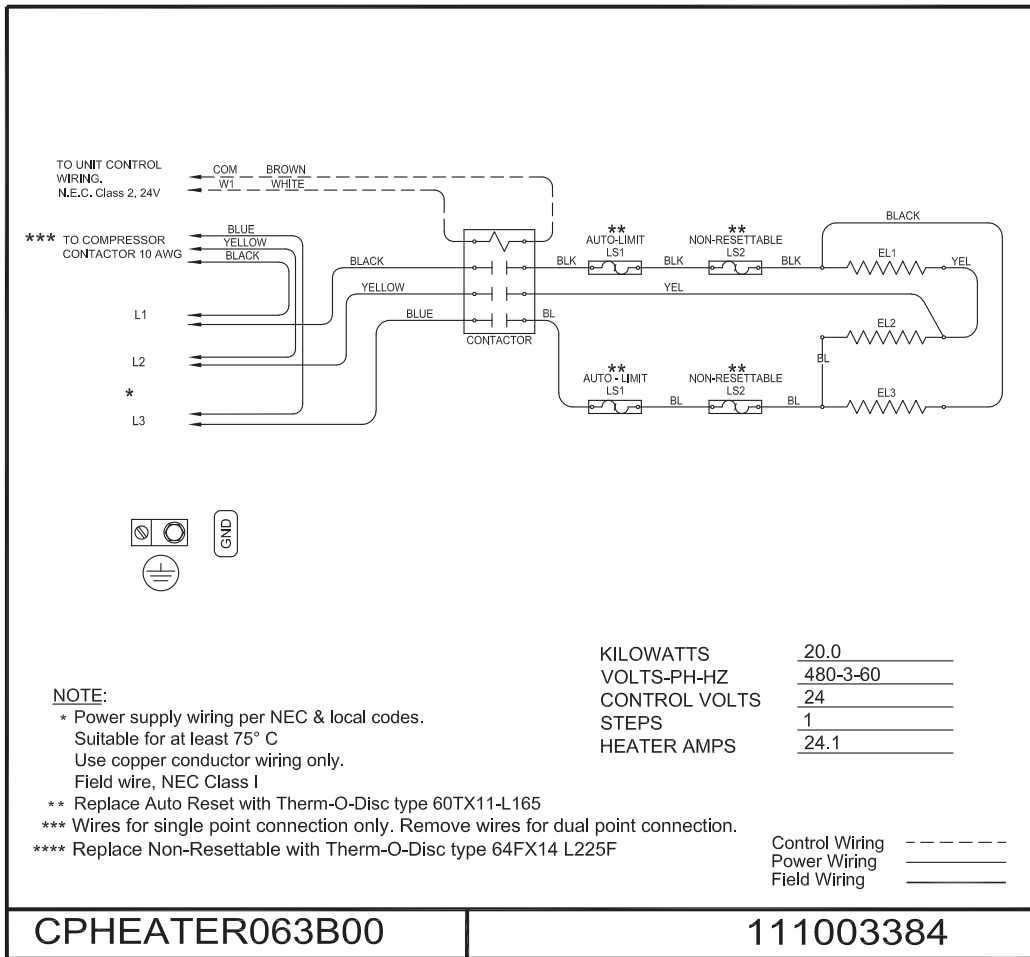

Fig. 24 - CPHEATER063B00 Wiring Diagram

A190195

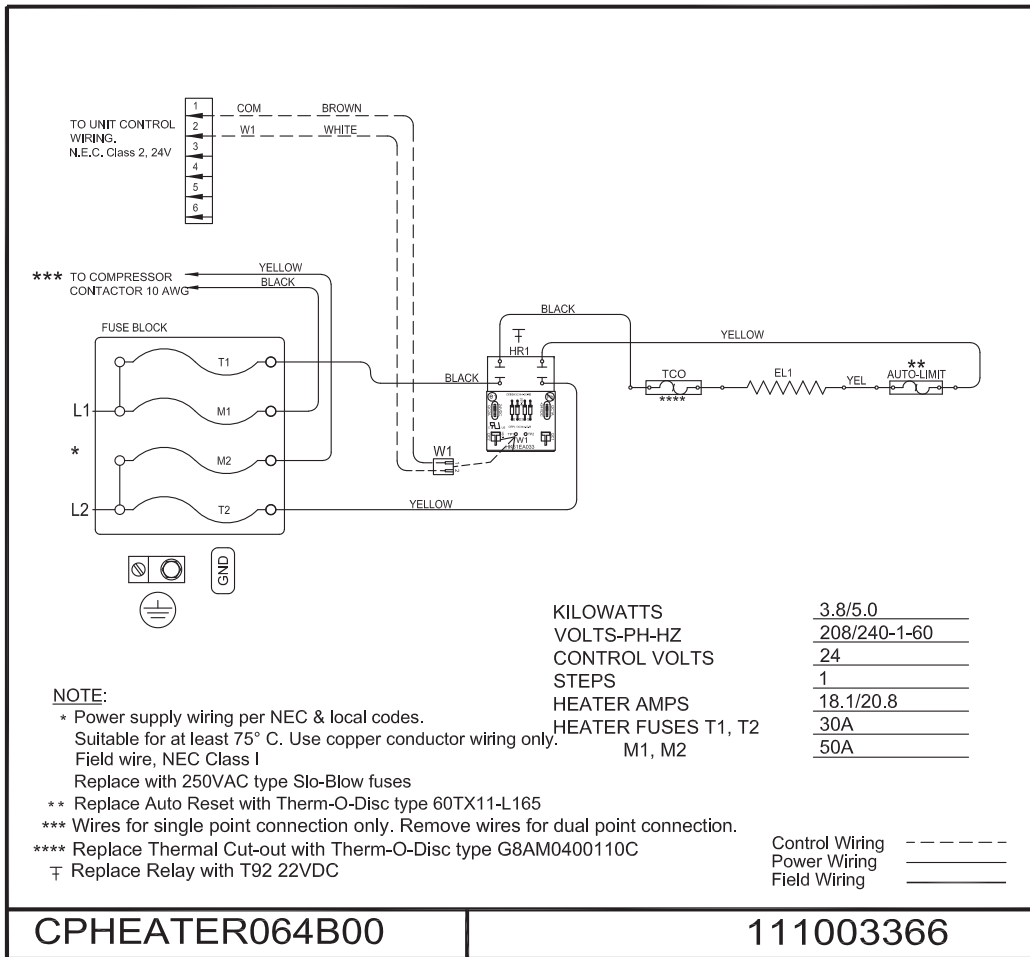

Fig. 25 - CPHEATER064B00 Wiring Diagram

A190177

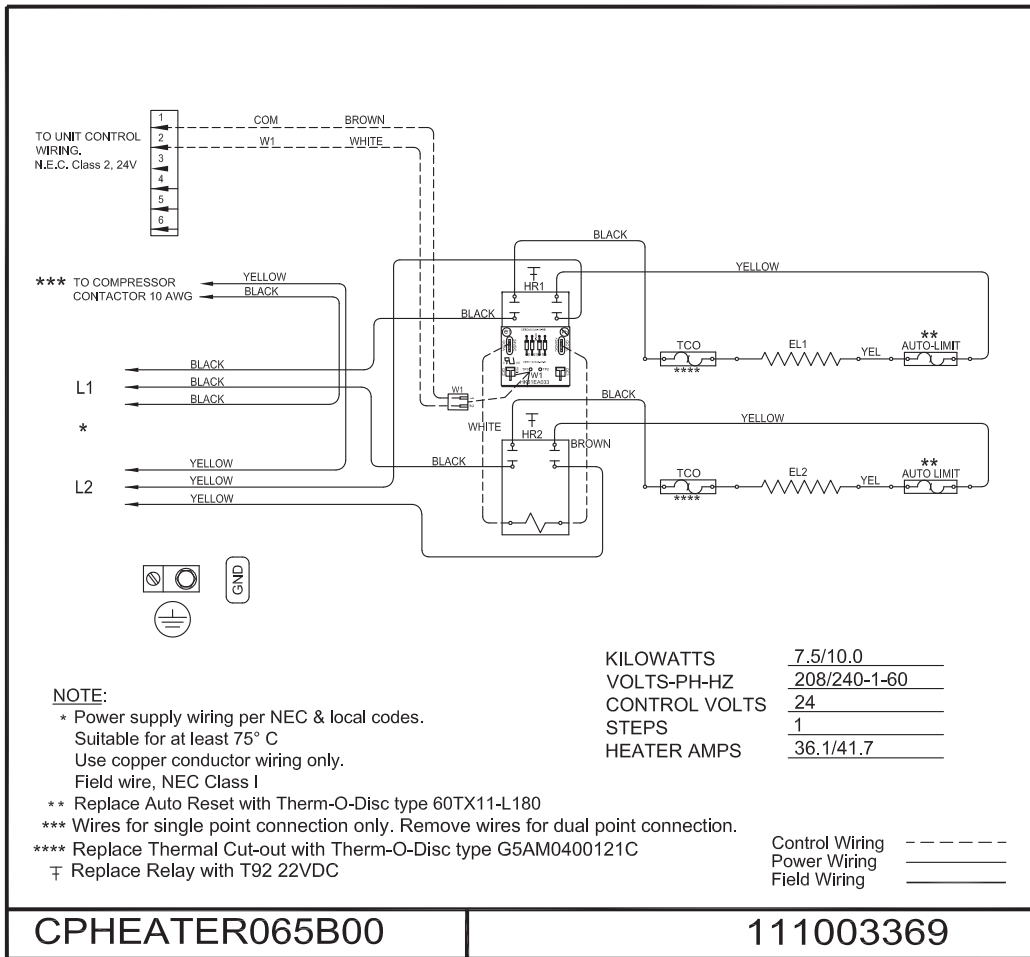

Fig. 26 - CPHEATER065B00 Wiring Diagram

A190180

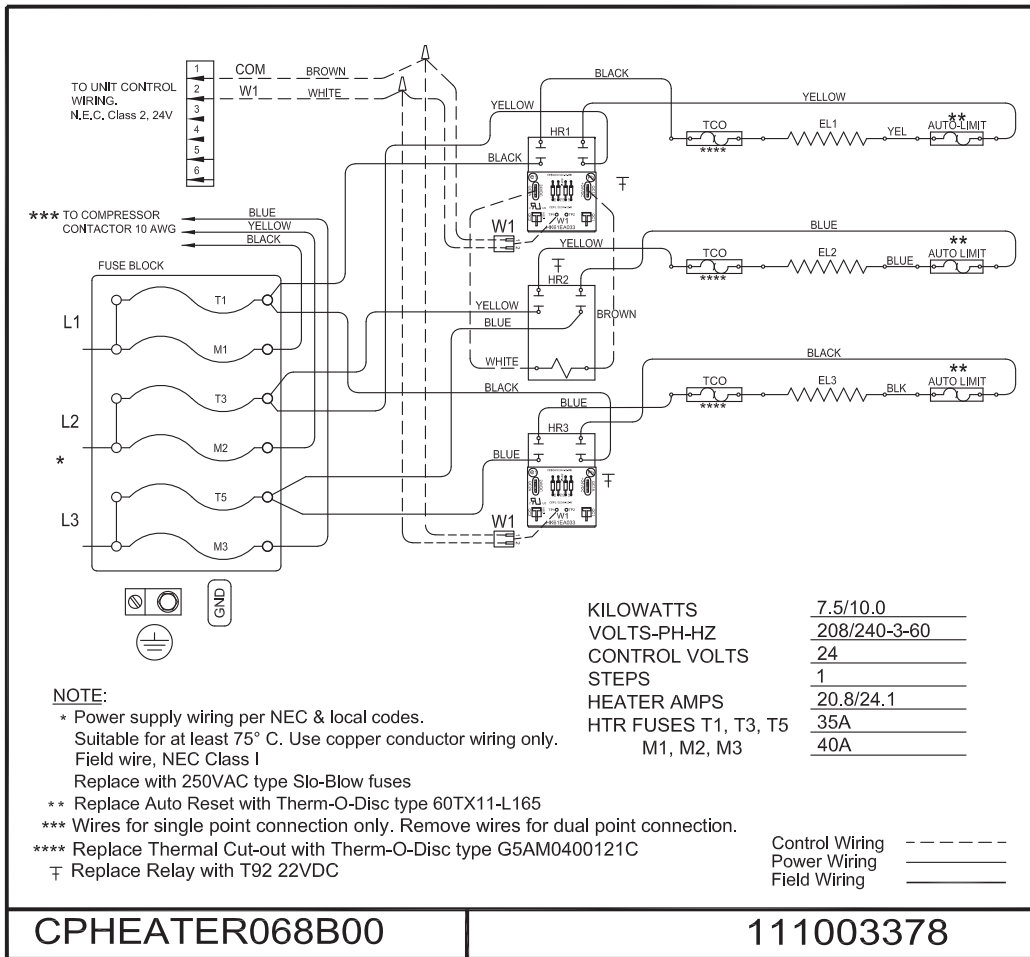

Fig. 28 - CPHEATER068B00 Wiring Diagram

A190189

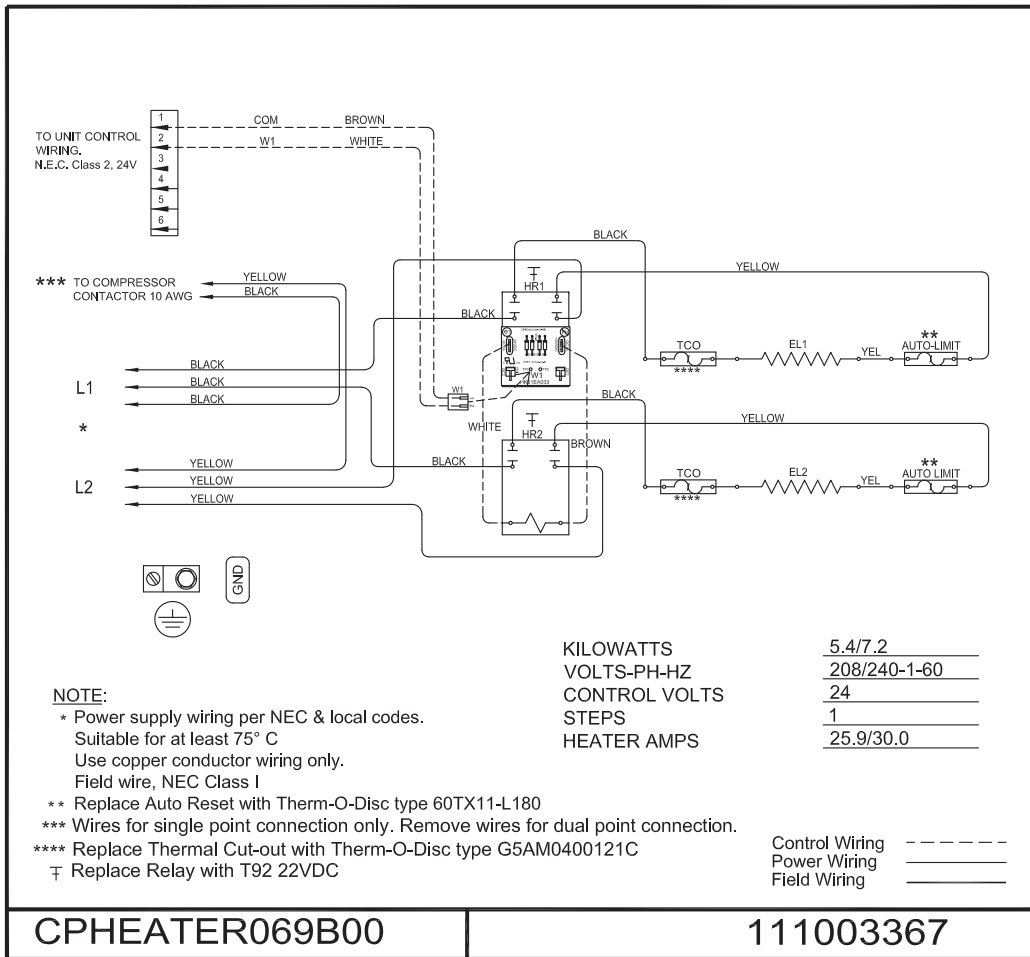

Fig. 29 - CPHEATER069B00 Wiring Diagram

A190178

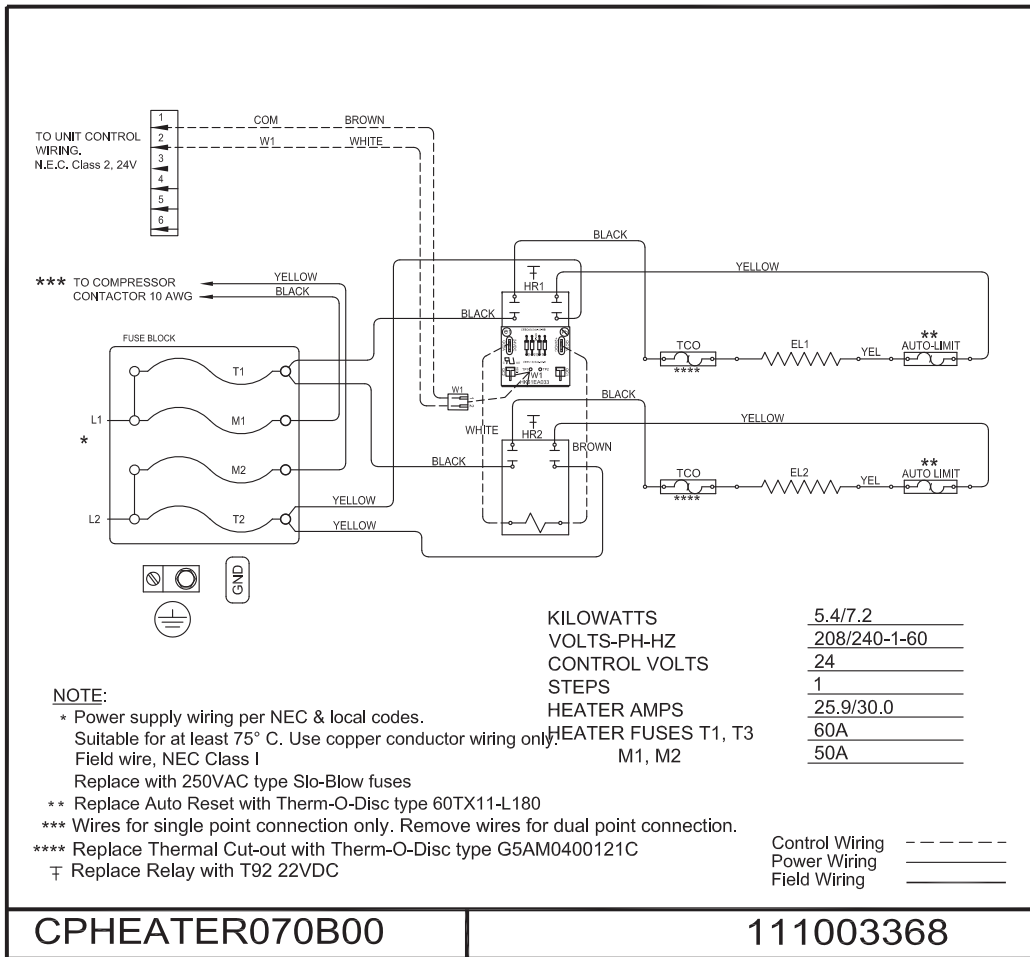

Fig. 30 - CPHEATER070B00 Wiring Diagram

A190179

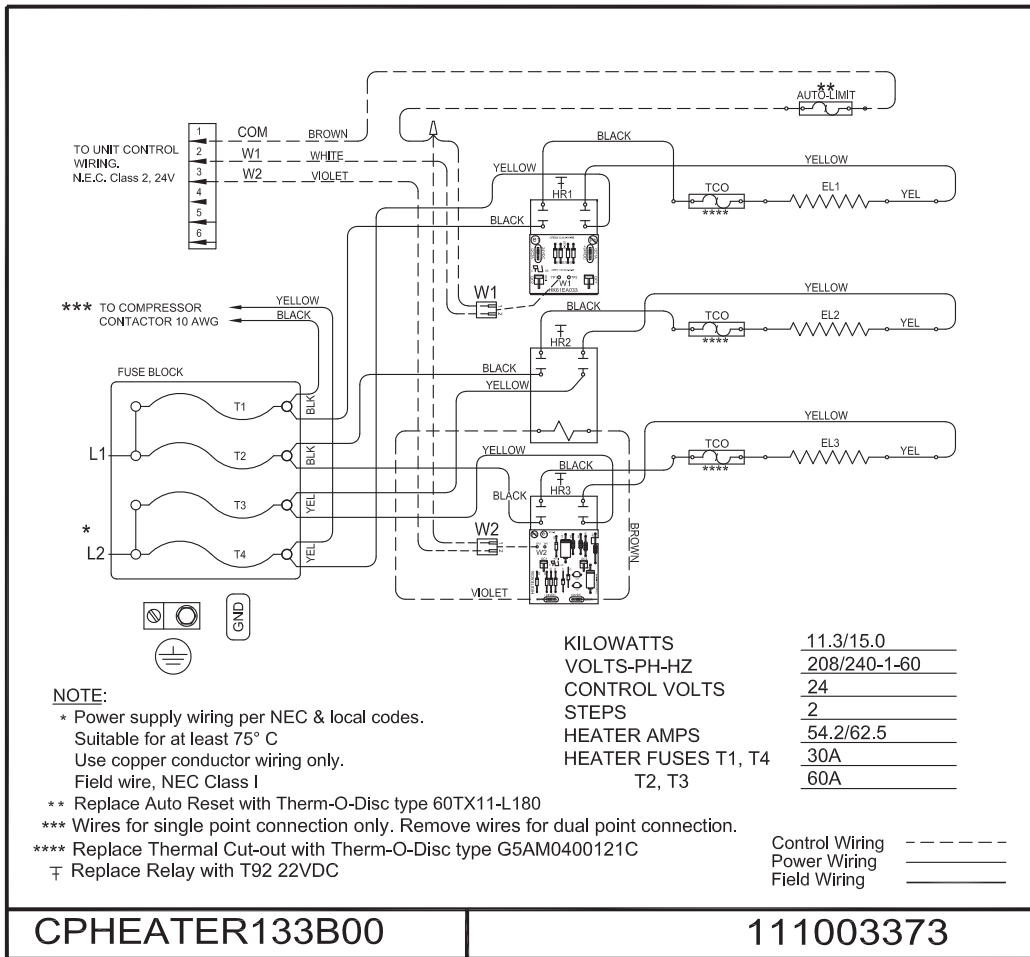

Fig. 31 - CPHEATER133B00 Wiring Diagram

A190184

