

COMMERCIAL SPLIT SYSTEMS HEAT PUMP UNITS R-410A, 6 – 20 TONS

BUILT TO LAST, EASY TO INSTALL AND SERVICE

- Single stage cooling capacity control on 072 to 121 models, two stage cooling capacity control on 180 to 240 models
- All models utilize round copper tube, aluminum plate fin condenser coils (RTPF)
- Brass suction and liquid line service valves
- Fully hermetic scroll compressors with crankcase heater and suction line accumulators
- Compressors include overload protection and vibration isolation for further enhancement of quiet operation
- Comfort Alert™ diagnostic and troubleshooting control system
 - LED Go-No-Go and fault code
 - Built in time guard anti-short cycle
 - Phase protection
 - Fault code retention logic
 - Low volt compressor contactor protector
- Full perimeter base rail with built-in rigging adapters and fork truck slots
- Pre-painted exterior panels and primer-coated interior panels tested to 500 hours salt spray protection
- Filter drier standard with each unit (shipped for field installation)
- Direct drive permanently lubricated condenser fan motors
- Newly designed terminal board facilitates simple safety circuit troubleshooting and simplified control box arrangement
- All units have high pressure and loss of charge protection
- Outdoor temperature cooling operation range up to 125°F (52°C) and down to 35°F (2°C)
- Models with optional low ambient control provide cooling operation down to -20°F (-29°C)
- All units factory run tested

WARRANTY

- 5 Year compressor limited warranty
- 1 Year parts limited warranty



CHS072-121



CHS240



180 & 240 models



Use of the AHRI Certified TM Mark indicates a manufacturer's participation in the program. For verification of certification for individual products, go to www.ahridirectory.org.



072 to 121 models

UNIT PERFORMANCE DATA ¹							
Model Number	Cooling Circuits	COOLING			Total Power (KW)	Unit Dimensions H x W x L Inches [mm]	Ship Weight lb. / kg
		Nominal Capacity Ton	Net Capacity BTUH	E.E.R			
CHS072*AA0A00A	1	6	70,000	11.0	6.4	42-3/8" x 59-3/8" x 45-7/8" [1077 x 1508 x 1164]	444 / 201
CHS091*AA0A00A	1	7.5	89,000	11.0	8.1	42-3/8" x 59-3/8" x 45-7/8" [1077 x 1508 x 1164]	483 / 219
CHS121*AA0A00A	1	10	112,000	11.0	10.2	50-3/8" x 59-3/8" x 45-7/8" [1279 x 1507 x 1164]	575 / 261
CHS180*DA0A00A	2	15	178,000	10.6	16.8	50-3/8" x 86-3/8" x 45-1/8" [1279 x 2193 x 1148]	768 / 348
CHS240*DA0A00A	2	20	222,000	10.7	20.8	50-3/8" x 86-3/8" x 67-1/8" [1279 x 2193 x 1704]	1015 / 460

* - Indicates Unit voltage: H = 208/230-3-60, L = 460-3-60, S = 575-3-60

¹ - Above ratings are with matching size FHS air handling unit

MODEL NOMENCLATURE

MODEL SERIES	C	H	S	0	9	1	H	A	A	0	A	0	0	A
Position Number	1	2	3	4	5	6	7	8	9	10	11	12	13	14
C = R-410A Condensing Unit														
H = Heat Pump Type														
S = Standard ASHRAE 90.1-2010 Efficiency Efficiency														
072 = 6 Tons (Single Compressor) 091 = 7.5 Tons (Single Compressor) 121 = 10 Tons (Single Compressor) 180 = 15 Tons (Dual Compressor) 240 = 20 Tons (Dual Compressor) Nominal Cooling Capacity														
H = 208/230-3-60 L = 460-3-60 S = 575-3-60 Voltage														
A = Single Circuit B = Single Circuit w/ Low Ambient Control D = Dual Circuit E = Dual Circuit w/ Low Ambient Control Refrigerant System Options														
A = Standard Al Fin / Copper Tube B = Pre-Coated Al Fin / Copper Tube C = E-Coat Al Fin / Copper Tube Outdoor Coil Options														
0 = None 1 = Non-powered 115v Convenience Outlet Service Options														
A = None C = Non-Fused Disconnect Electrical Options														
0 = Standard Electrical Mechanical Base Unit Controls														
0 = No Options Future Use														
A = Original Design														

Table 1 – CHS FACTORY INSTALLED OPTIONS AND FIELD INSTALLED ACCESSORIES

ITEM	FACTORY INSTALLED OPTION	FIELD INSTALLED ACCESSORY
Disconnect Switch (non-fused) *	X	
Coil Protection Applications	X	
Non-powered Convenience Outlet (115-v)	X	
Low Ambient temperature head pressure controller	X	X
Louvered Hail Guard		X
Wired Condenser Coil Grille		X

* Not available when unit MOCAP electrical rating exceeds 80 amps.

CHS factory-installed options

Outdoor coil options are available to match coil protection to site conditions for optimum durability. See the table below and refer to the Application data for selection guidance.

Low ambient temperature Motormaster® head pressure control operates in cooling mode at outdoor temperatures below 55° F. The Motormaster control varies the speed of outdoor-fan motors to maintain correct condensing temperature down to -20° F.

Non-powered convenience outlet requires the field installation of a general purpose 125-volt 15-A circuit powered from a source elsewhere in the building.

Non-fused disconnect switch removes power locally at the condensing unit. This switch also includes a power lockout capability to protect the service person. This lockout switch saves time and effort as the service person no longer needs to access a distant disconnect switch while servicing the unit.

Outdoor coil louvered hail guard protects outdoor units from hail and other flying debris.

Outdoor coil grille protects outdoor coil from large objects and vandalism.

DESCRIPTION	ENVIRONMENT					
	Standard Non-Corrosive	Mild Coastal	Moderate Coastal	Severe Coastal	Industrial	Combined Coastal and Industrial
Alum Fin / Copper Tube	X					
Pre-Coated Al/Copper		X				
E-Coated Al/Copper		X	X	X	X	X

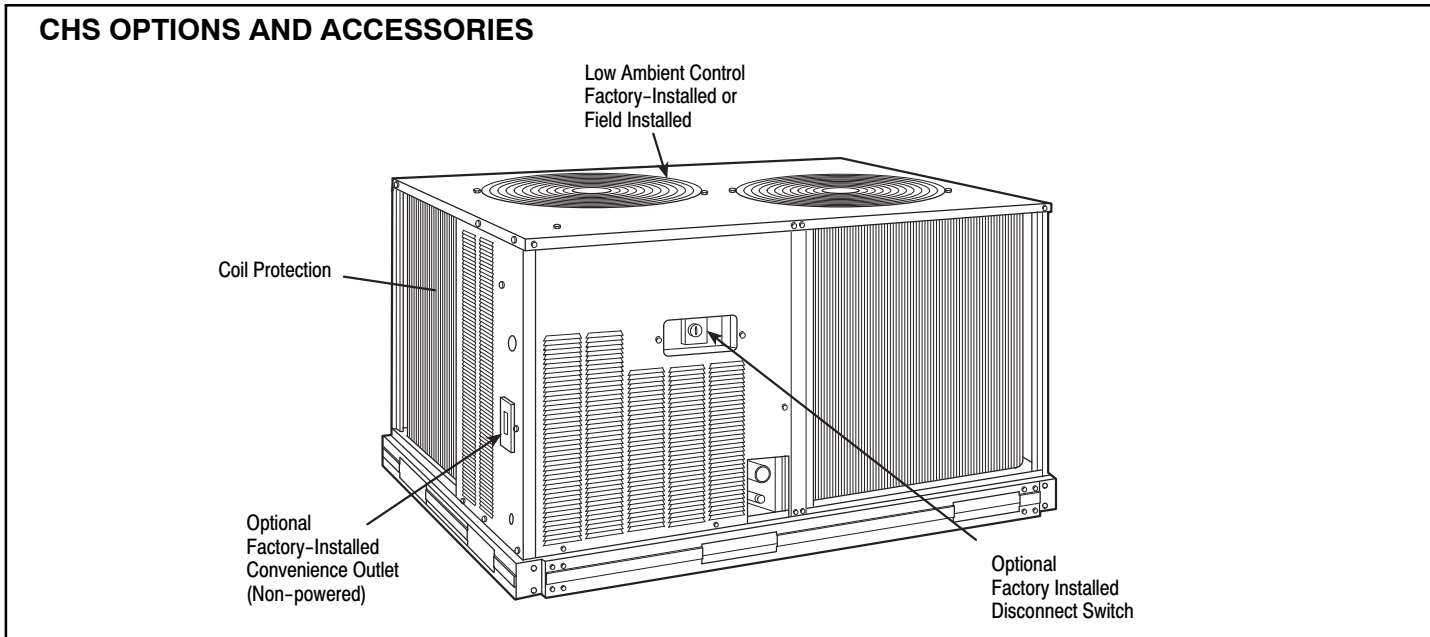

ACCESSORIES – CHS

LOW AMBIENT CONTROLS		
Model Number	Description	Use With Model Size
CALOWAMB004A00	Low Ambient Temperature Head Pressure Controller, allows cooling operation down to -20°F by varying the speed on the condenser fan.*	072 – 121 (208/230-3-60v only)
CALOWAMB005A00		072 – 091 (460-3-60v only)
CALOWAMB009A00		121 (460-3-60v only)
CALOWAMB006A00		072 – 121 (575-3-60v only)
CALOWAMB024A00	Low Ambient Temperature Head Pressure Controller, allows cooling operation down to -20°F by varying the speed on the condenser fan.*	180 (208/230-3-60v only)
CALOWAMB025A00		180 (460-3-60v only)
CALOWAMB026A00		180 (575-3-60v only)
CALOWAMB027A00		240 (208/230-3-60v only)
CALOWAMB028A00		240 (460-3-60v only)
CALOWAMB029A00		240 (575-3-60v only)

* Includes variable speed motor controller, outdoor motor, and bracket.

LOUVERED HAIL GUARDS – CONDENSER COIL		
Model Number	Description	Use With Model Size
CALVHLGD005A00	Louvered Condenser Coil Hail Guard – Includes louvered panel(s) to protect condenser coil from damage and vandalism	072
CALVHLGD006A00		091
CALVHLGD010A00		121
CALVHLGD008A00	Louvered Condenser Coil Hail Guard – Includes louvered panel(s) to protect condenser coil from damage and vandalism	180
CALVHLGD009A00		240

WIRED GUARDS – CONDENSER COIL		
Model Number	Description	Use With Model Size
CAGRILLE010A00	Wired Grille Condenser Coil Guard – Includes panel(s) to protect condenser coil from larger objects	072
CAGRILLE011A00		091
CAGRILLE015A00		121

LIQUID LINE SOLENOID VALVES (LLSV)		
Model Number**	Description	Use With Liquid Line Size
1179871 ¹	Liquid Line Solenoid Valve	3/8" L
1179872 ¹	Liquid Line Solenoid Valve	1/2" L
1179873 ¹	Liquid Line Solenoid Valve	5/8" L
1179874 ¹	Liquid Line Solenoid Valve Coil	All LLSVs listed

BI-FLOW SIGHT GLASSES		
Model Number**	Description	Use With Liquid Line Size
1179879	Sight Glass	3/8" L
1179878	Sight Glass	1/2" L
1179877	Sight Glass	5/8" L

¹ Bi-Flow kit 1183150 is also required

^{††} Bushings required on all except on CHS091 with 1/2" liquid line

L – Liquid line

S – Suction Line

** Available from FAST Parts

Table 2 – AHRI* CAPACITY RATINGS

PERFORMANCE DATA COOLING						
UNIT CHS	COOLING CIRCUITS	NOMINAL CAPACITY (TONS)	NET COOLING CAPACITY (BTUH)	TOTAL POWER (KW)	EER	IEER
072	1	6	70,000	6.4	11.0	12.6
091	1	7.5	89,000	8.1	11.0	12.0
121	1	10	112,000	10.2	11.0	12.0
180	2	15	178,000	16.8	10.6	11.0
240	2	20	222,000	20.8	10.7	11.0

PERFORMANCE DATA HEATING						
Unit CHS	HIGH HEAT AT 47°F (8°C)			LOW HEAT AT 17°F (-8°C)		
	Net Heating Capacity (MBH)	Total Power (kW)	COP	Net Heating Capacity (MBH)	Total Power (kW)	COP
072	66.0	5.9	3.30	39.0	5.2	2.40
091	87.0	7.7	3.30	52.0	6.9	2.40
121	106.0	9.4	3.30	70.0	9.3	2.40
180	178.0	15.3	3.40	108.0	13.2	2.40
240	214.0	17.9	3.50	130.0	15.9	2.40

* Above ratings are with matching size FHS air handling unit.

LEGEND

- AHRI – Air-Conditioning, Heating and Refrigeration Institute
- ASHRAE – American Society of Heating, Refrigerating and Air Conditioning, Inc.
- EER – Energy Efficiency Ratio
- IEER – Integrated Energy Efficiency Ratio

NOTES

1. Rated in accordance with AHRI Standard.
2. Ratings are based on:
Cooling Standard: 27°C (80°F) db, 19°C (67°F) wb indoor air temp and 35°C (95°F) db outdoor air temp.
IEER Standard: 27°C (80°F) db, 19°C (67°F) wb indoor air temp and 4 various outdoor temperatures.
3. All units comply with ASHRAE 90.1 Energy Standard for minimum EER and IEER requirements.
4. All units are AHRI listed as factory defined matched combinations of specific indoor and outdoor unit components.



Use of the AHRI Certified TM Mark indicates a manufacturer's participation in the program. For verification of certification for individual products, go to www.ahridirectory.org .



072 to 121 models



180 & 240 models

Table 3 – SOUND LEVELS

SOUND POWER LEVELS, dB									
Unit CHS	OUTDOOR SOUND (dB)								
	A-Weighted	63	125	250	500	1000	2000	4000	8000
072	82	86.4	86.0	79.2	80.2	77.6	72.0	67.9	62.3
091	82	86.8	85.7	80.3	80.3	77.7	72.3	70.2	65.4
121	82	82.8	81.5	79.2	79.4	76.2	72.3	69.4	64.2
180	80	90.3	81.8	78.0	76.7	75.2	70.5	66.4	61.9
240	85	91.0	85.0	80.0	86.0	79.0	73.0	68.0	63.0

LEGEND

dB = Decibel

Table 4 – PHYSICAL DATA

PHYSICAL DATA					
UNIT: CHS	072	091	121	180	240
Refrigeration System					
# Circuits / # Comp. / Type	1 / 1 / Scroll	1 / 1 / Scroll	1 / 1 / Scroll	2 / 2 / Scroll	2 / 2 / Scroll
Shipping charge R-410A (lbs)	9.0	9.0	9.0	9.0 / 9.0	9.0 / 9.0
System charge w/ fan coil * (lbs)	18	21	27	21 / 21	27 / 27
High-press. Trip / Reset (psig)	630 / 505	630 / 505	630 / 505	630 / 505	630 / 505
Low-press. Trip / Reset (psig)	27 / 44	27 / 44	27 / 44	27 / 44	27 / 44
Outdoor Coil					
Material – Tube / Fin	Al/Cu	Al/Cu	Al/Cu	Al/Cu	Al/Cu
Round Tube Plate Fin Coil type	RTPF	RTPF	RTPF	RTPF	RTPF
Rows / FPI	2 / 17	2 / 17	2 / 17	2 / 17	2 / 17
Total Face Area (ft2)	17.5	23.0	28.1	47.1	50.1
Outdoor fan / motor					
Qty / Motor drive type	2 / direct	2 / direct	2 / direct	3 / direct	4 / direct
Motor HP / RPM	1/4 / 1100	1/4 / 1100	1/4 / 1100	1/4 / 1100	1/4 / 1100
Fan diameter (in)	22	22	22	22	22
Watts (total)	610	610	610	970	1150
Piping Connections					
Qty / Vapor (in. ODS)	1 / 1-1/8	1 / 1-1/8	1 / 1-3/8	2 / 1-3/8	2 / 1-3/8
Qty / Liquid (in. ODS)	1 / 3/8	1 / 1/2	1 / 1/2	2 / 1/2	2 / 1/2

* Approximate system charge with 25 ft. piping of sizes indicated with matched FHS

Table 5 – DIMENSIONS AND WEIGHTS, 6 – 10 TON

Unit CHS	ELECTRICAL CHARACTERISTICS	STD. UNIT WT.		CORNER A		CORNER B		CORNER C		CORNER D		CENTER OF GRAVITY			UNIT HEIGHT
		LBS.	KG.	LBS.	KG.	LBS.	KG.	LBS.	KG.	LBS.	KG.	X	Y	Z	H
072	208/230-3-60,460-3-60,575-3-60	444	201	134	61	97	44	90	41	123	56	22 [558.8]	25 [635.0]	13 [330.2]	42-3/8 [1076.0]
091	208/230-3-60,460-3-60,575-3-60	483	219	162	74	110	50	85	39	125	57	20 [508.0]	24 [609.6]	21 [533.4]	42-3/8 [1076.0]
121	208/230-3-60,460-3-60,575-3-60	575	261	186	84	126	57	106	48	157	71	21 [533.4]	24 [609.6]	23 [584.2]	50-3/8 [1279.2]

NOTES:

- MINIMUM CLEARANCE (LOCAL CODES OR JURISDICTION MAY PREVAIL):
 - BOTTOM TO COMBUSTIBLE SURFACES: 0 INCHES.
 - OUTDOOR COIL, FOR PROPER AIR FLOW: 36 INCHES [914] ONE SIDE, 12 INCHES [305] THE OTHER. THE SIDE GETTING THE GREATER CLEARANCE IS OPTIONAL.
 - OVERHEAD: 60 INCHES [1524], TO ASSURE PROPER OUTDOOR FAN OPERATION.
 - BETWEEN UNITS: CONTROL BOX SIDE, 42 INCHES [1067] PER NEC.
 - BETWEEN UNIT AND UNGROUNDED SURFACES: CONTROL BOX SIDE, 36 INCHES [914] PER NEC.
 - BETWEEN UNIT AND BLOCK OR CONCRETE WALLS AND OTHER GROUNDED SURFACES: CONTROL BOX SIDE, 42 INCHES [1067] PER NEC.
- WITH EXCEPTION OF THE CLEARANCE FOR THE OUTDOOR COIL AS STATED IN NOTE 1B, A REMOVABLE FENCE OR BARRICADE REQUIRES NO CLEARANCE.
- UNITS MAY BE INSTALLED ON COMBUSTIBLE FLOORS MADE FROM WOOD OR CLASS A, B OR C ROOF COVERING MATERIAL.

Unit CHS	SERVICE VALVE CONNECTIONS	
	SUCTION	LIQUID
072	1-1/8 [28.6]	3/8 [9.5]
091	1-1/8 [28.6]	1/2 [12.7]
121	1-3/8 [34.9]	1/2 [12.7]

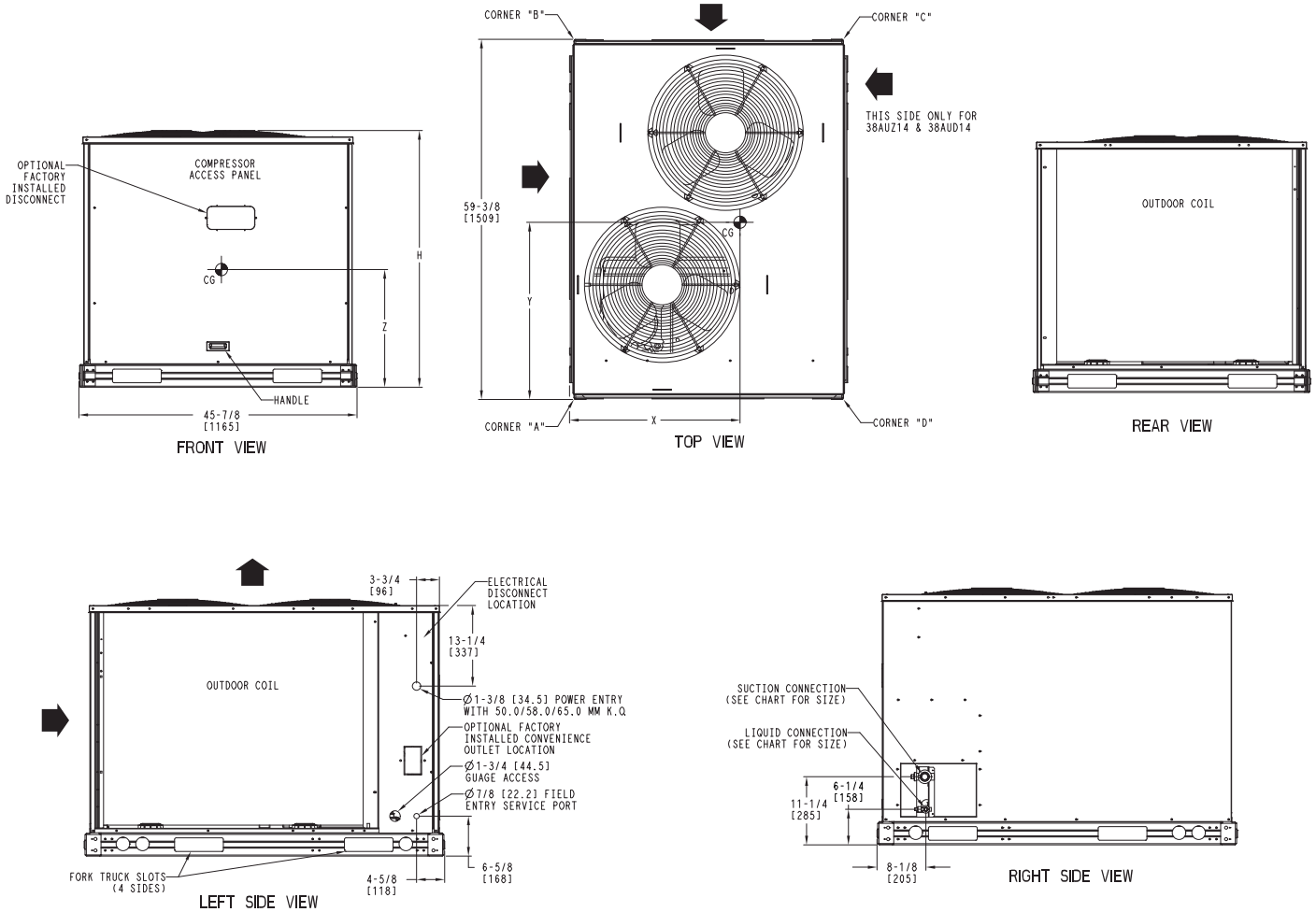
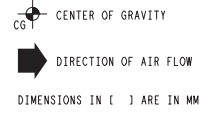

Table 6 – DIMENSIONS AND WEIGHTS, 15 TON

UNIT CHS	ELECTRICAL CHARACTERISTICS	STD. UNIT WT.		CORNER A		CORNER B		CORNER C		CORNER D		CENTER OF GRAVITY			UNIT HEIGHT				
		LBS.	KG.	LBS.	KG.	LBS.	KG.	LBS.	KG.	LBS.	KG.	X	Y	Z	H				
180	208/230-3-60,460-3-60,575-3-60	768	348	236	107	183	83	153	69	196	89	39	1990.6	20	508	23	584.2	50-3/8	1279.2

SERVICE VALVE CONNECTIONS			
UNIT	SUCTION	LIQUID	QTY
180	1-3/8 [34.9]	1/2 [12.7]	2 EA



DIMENSIONS IN [] ARE IN MM

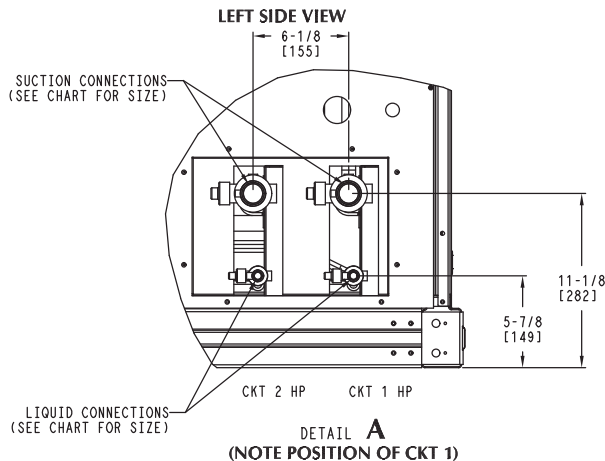
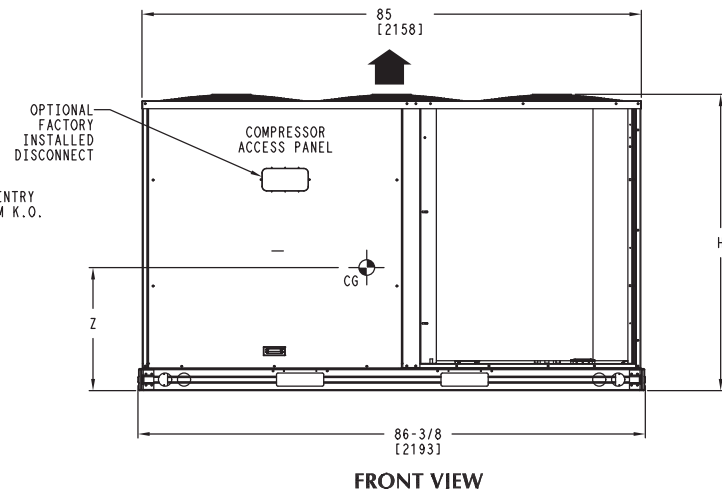
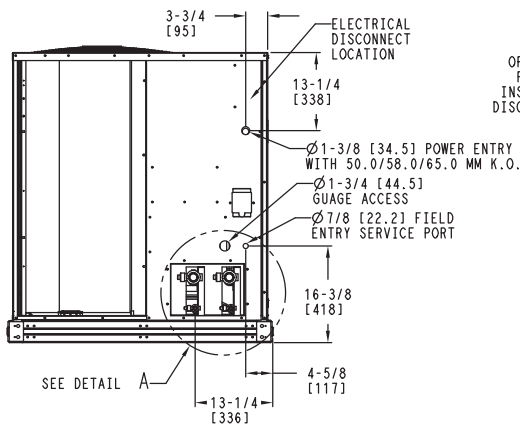
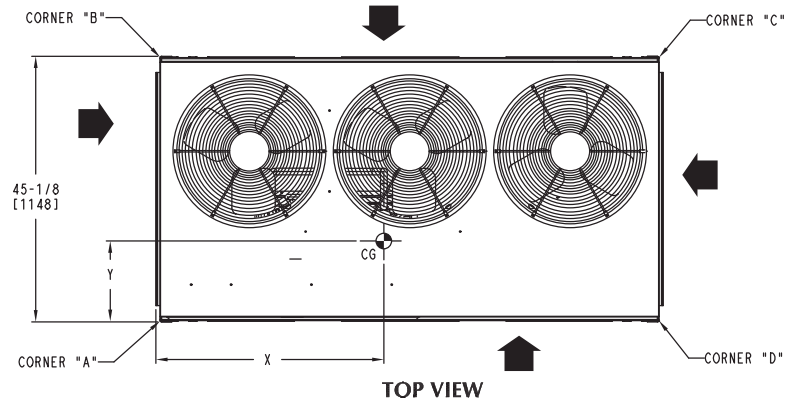



NOTES:

- MINIMUM CLEARANCE (LOCAL CODES OR JURISDICTION MAY PREVAIL):
 - BOTTOM TO COMBUSTIBLE SURFACES: 0 INCHES.
 - OUTDOOR COIL, FOR PROPER AIR FLOW: 36 INCHES ONE SIDE, 12 INCHES THE OTHER. THE SIDE GETTING THE GREATER CLEARANCE IS OPTIONAL.
 - OVERHEAD: 60 INCHES, TO ASSURE PROPER OUTDOOR FAN OPERATION.
 - BETWEEN UNITS: CONTROL BOX SIDE, 42 INCHES PER NEC.
 - BETWEEN UNIT AND UNGROUNDED SURFACES: CONTROL BOX SIDE, 36 INCHES PER NEC.
 - BETWEEN UNIT AND BLOCK OR CONCRETE WALLS AND OTHER GROUNDED SURFACES: CONTROL BOX SIDE, 42 INCHES PER NEC.
- WITH EXCEPTION OF THE CLEARANCE FOR THE OUTDOOR COIL AS STATED IN NOTE 1B, A REMOVABLE FENCE OR BARRICADE REQUIRES NO CLEARANCE.
- UNITS MAY BE INSTALLED ON COMBUSTIBLE FLOORS MADE FROM WOOD OR CLASS A, B OR C ROOF COVERING MATERIAL.

Table 7 – DIMENSIONS AND WEIGHTS, 20 TON

UNIT CHS	ELECTRICAL CHARACTERISTICS	STD. UNIT WT.		CORNER A		CORNER B		CORNER C		CORNER D		CENTER OF GRAVITY			UNIT HEIGHT
		LBS.	KG.	LBS.	KG.	LBS.	KG.	LBS.	KG.	LBS.	KG.	X	Y	Z	H
240	208/230-3-60,460-3-60,575-3-60	1015	460	354	161	224	102	170	77	268	122	37-1/4 [946.1]	26 [660.4]	23 [584.2]	50-3/8 [1279.2]

SERVICE VALVE CONNECTIONS			
UNIT	SUCTION	LIQUID	QTY
240	1-3/8 [34.9]	1/2 [12.7]	2 EA

 CENTER OF GRAVITY
 DIRECTION OF AIR FLOW
 DIMENSIONS IN [] ARE IN MM

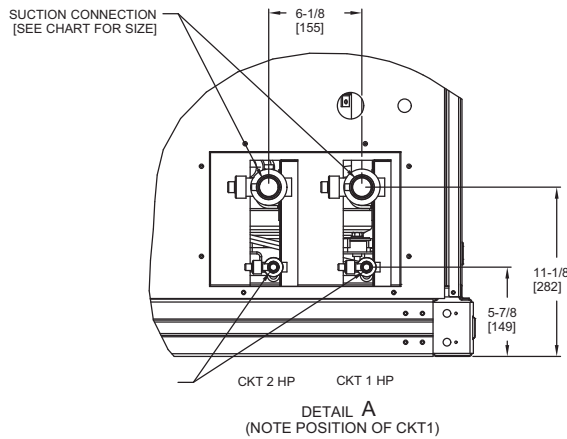
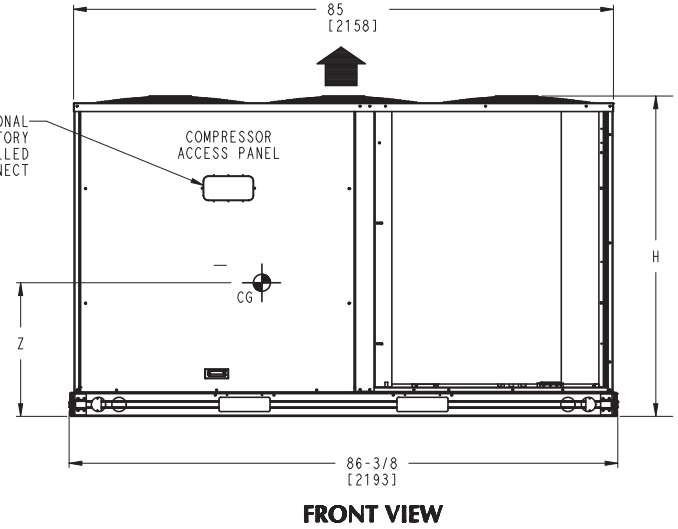
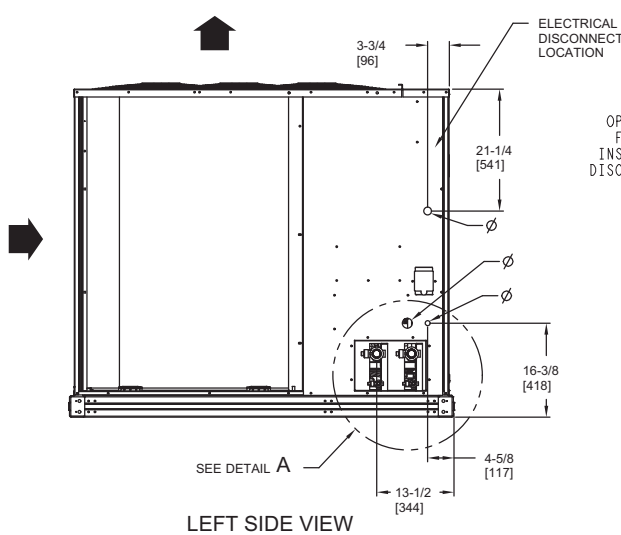
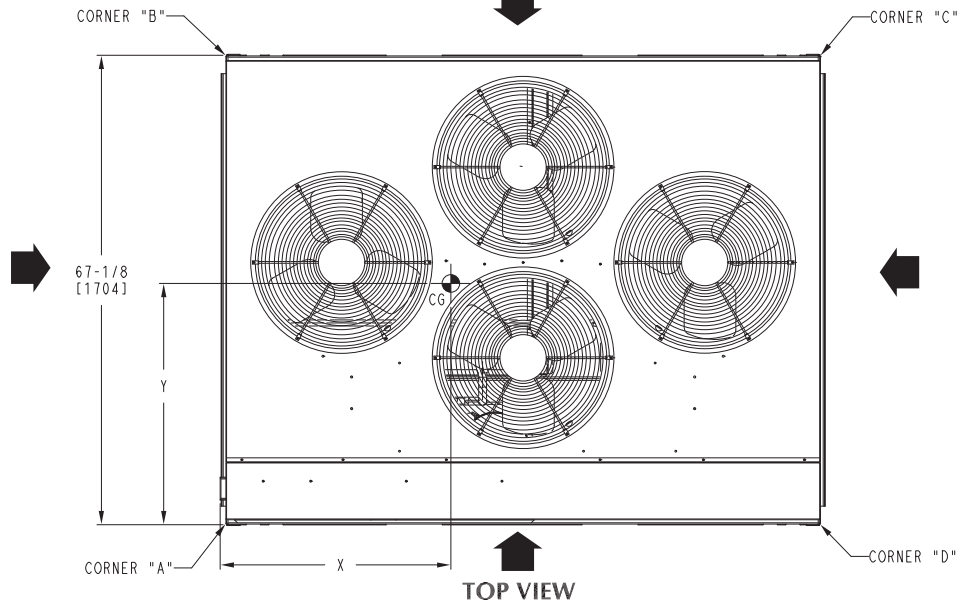

- NOTES:**
- MINIMUM CLEARANCE (LOCAL CODES OR JURISDICTION MAY PREVAIL):
 - BOTTOM TO COMBUSTIBLE SURFACES: 0 INCHES.
 - OUTDOOR COIL, FOR PROPER AIR FLOW: 36 INCHES ONE SIDE, 12 INCHES THE OTHER. THE SIDE GETTING THE GREATER CLEARANCE IS OPTIONAL.
 - OVERHEAD: 60 INCHES, TO ASSURE PROPER OUTDOOR FAN OPERATION.
 - BETWEEN UNITS: CONTROL BOX SIDE, 42 INCHES PER NEC.
 - BETWEEN UNIT AND UNGROUNDED SURFACES: CONTROL BOX SIDE, 36 INCHES PER NEC.
 - BETWEEN UNIT AND BLOCK OR CONCRETE WALLS AND OTHER GROUNDED SURFACES: CONTROL BOX SIDE, 42 INCHES PER NEC.
 - WITH EXCEPTION OF THE CLEARANCE FOR THE OUTDOOR COIL AS STATED IN NOTE 1B, A REMOVABLE FENCE OR BARRICADE REQUIRES NO CLEARANCE.
 - UNITS MAY BE INSTALLED ON COMBUSTIBLE FLOORS MADE FROM WOOD OR CLASS A B OR C ROOF COVERING MATERIAL

PERFORMANCE DATA

CHS072, FHS072

COOLING COMBINATION RATINGS

CHS072 / FHS072				AMBIENT TEMPERATURE															
				85			95			105			115			125			
				EA (DB)			EA (DB)			EA (DB)			EA (DB)			EA (DB)			
				75	80	85	75	80	85	75	80	85	75	80	85	75	80	85	
1800 Cfm	EA (wB)	58	THC	63.5	63.5	71.3	61.2	61.2	68.8	58.8	58.8	66.1	56.3	56.3	63.3	53.5	53.5	60.2	
			SHC	55.7	63.5	71.3	53.7	61.2	68.8	51.6	58.8	66.1	49.3	56.3	63.3	46.9	53.5	60.2	
		62	THC	66.4	66.4	68.3	63.5	63.5	66.8	60.5	60.5	65.2	57.3	57.3	63.5	54.0	54.0	61.5	
			SHC	50.6	59.5	68.3	49.2	58.0	66.8	47.6	56.4	65.2	46.0	54.8	63.5	44.2	52.9	61.5	
		67	THC	72.8	72.8	72.8	69.6	69.6	69.6	66.3	66.3	66.3	62.7	62.7	62.7	59.0	59.0	59.0	
			SHC	41.6	50.5	59.4	40.2	49.1	58	38.7	47.6	56.6	37.2	46.1	55	35.6	44.5	53.4	
	72	THC	79.7	79.7	79.7	76.2	76.2	76.2	72.5	72.5	72.5	68.6	68.6	68.6	64.5	64.5	64.5		
		SHC	32.4	41.4	50.5	31.0	40.1	49.1	29.6	38.6	47.6	28.1	37.1	46.1	26.5	35.5	44.5		
	76	THC	-	85.5	85.5	-	81.7	81.7	-	77.7	77.7	-	73.5	73.5	-	69.1	69.1		
		SHC	-	34.2	44	-	32.8	42.5	-	31.4	41	-	29.9	39.4	-	28.4	37.8		
	2100 Cfm	EA (wB)	58	THC	66.7	66.7	74.9	64.2	64.2	72.2	61.6	61.6	69.3	58.9	58.9	66.2	55.9	55.9	62.9
				SHC	58.4	66.7	74.9	56.3	64.2	72.2	54.0	61.6	69.3	51.5	58.9	66.2	49.0	55.9	62.9
62			THC	68.4	68.4	74.3	65.4	65.4	72.6	62.3	62.3	70.7	59.0	59.0	68.8	55.9	55.9	65.3	
			SHC	54.1	64.2	74.3	52.5	62.6	72.6	50.8	60.8	70.7	49.1	59.0	68.8	46.6	55.9	65.3	
67			THC	74.8	74.8	74.8	71.5	71.5	71.5	67.9	67.9	67.9	64.2	64.2	64.2	60.3	60.3	60.3	
			SHC	43.9	54.2	64.4	42.5	52.7	63	41.0	51.2	61.4	39.4	49.6	59.9	37.8	48.0	58.2	
72		THC	81.8	81.8	81.8	78.2	78.2	78.2	74.3	74.3	74.3	70.2	70.2	70.2	65.9	65.9	65.9		
		SHC	33.4	43.8	54.1	32.0	42.3	52.7	30.5	40.9	51.2	29.0	39.3	49.6	27.4	37.7	47.9		
76		THC	-	87.7	87.7	-	83.7	83.7	-	79.5	79.5	-	75.1	75.1	-	70.4	70.4		
		SHC	-	35.5	46.4	-	34.1	45	-	32.6	43.4	-	31.1	41.8	-	29.5	40.1		
2400 Cfm		EA (wB)	58	THC	69.3	69.3	78.0	66.7	66.7	75.1	64.0	64.0	72.0	61.0	61.0	68.7	57.9	57.9	65.2
				SHC	60.7	69.3	78.0	58.4	66.7	75.1	56.0	64.0	72.0	53.4	61.0	68.7	50.6	57.9	65.2
	62		THC	70.1	70.1	79.5	66.9	66.9	78.0	64.0	64.0	74.7	61.0	61.0	71.3	57.9	57.9	67.6	
			SHC	57.2	68.3	79.5	55.7	66.8	78.0	53.3	64.0	74.7	50.8	61.0	71.3	48.2	57.9	67.6	
	67		THC	76.4	76.4	76.4	72.9	72.9	72.9	69.2	69.2	69.2	65.3	65.3	65.3	61.2	61.2	62.7	
			SHC	46.1	57.6	69.1	44.6	56.1	67.6	43.1	54.6	66.1	41.5	52.9	64.4	39.8	51.2	62.7	
	72	THC	83.5	83.5	83.5	79.6	79.6	79.6	75.6	75.6	75.6	71.3	71.3	71.3	66.9	66.9	66.9		
		SHC	34.3	45.9	57.6	32.9	44.5	56.1	31.4	43.0	54.5	29.8	41.4	52.9	28.2	39.7	51.2		
	76	THC	-	89.4	89.4	-	85.2	85.2	-	80.8	80.8	-	76.2	76.2	-	71.5	71.5		
		SHC	-	36.7	48.8	-	35.2	47.3	-	33.7	45.7	-	32.2	44.1	-	30.5	42.4		
	2700 Cfm	EA (wB)	58	THC	71.6	71.6	80.6	68.9	68.9	77.5	66.0	66.0	74.2	62.9	62.9	70.8	59.6	59.6	67.1
				SHC	62.7	71.6	80.6	60.3	68.9	77.5	57.7	66.0	74.2	55.0	62.9	70.8	52.1	59.6	67.1
62			THC	71.7	71.7	83.7	68.9	68.9	80.4	66.0	66.0	77.0	62.8	62.8	73.4	59.6	59.6	69.6	
			SHC	59.7	71.7	83.7	57.3	68.9	80.4	54.9	66.0	77.0	52.3	62.8	73.4	49.5	59.6	69.6	
67			THC	77.6	77.6	77.6	74.0	74.0	74.0	70.2	70.2	70.5	66.2	66.2	68.7	62.0	62.0	66.9	
			SHC	48.1	60.9	73.6	46.6	59.4	72.1	45.0	57.8	70.5	43.4	56.1	68.7	41.7	54.3	66.9	
72		THC	84.8	84.8	84.8	80.8	80.8	80.8	76.6	76.6	76.6	72.3	72.3	72.3	67.7	67.7	67.7		
		SHC	35.1	48.0	60.8	33.7	46.5	59.3	32.2	44.9	57.7	30.6	43.3	56	28.9	41.6	54.3		
76		THC	-	90.7	90.7	-	86.4	86.4	-	81.9	81.9	-	77.2	77.2	-	72.3	72.3		
		SHC	-	37.8	51.1	-	36.3	49.5	-	34.8	47.9	-	33.2	46.2	-	31.5	44.5		
3000 Cfm		EA (wB)	58	THC	73.6	73.6	82.8	70.7	70.7	79.6	67.7	67.7	76.2	64.4	64.4	72.5	61.0	61.0	68.7
				SHC	64.4	73.6	82.8	61.9	70.7	79.6	59.2	67.7	76.2	56.3	64.4	72.5	53.3	61.0	68.7
	62		THC	73.6	73.6	86	70.7	70.7	82.6	67.7	67.7	79.1	64.4	64.4	75.3	61.0	61.0	71.3	
			SHC	61.2	73.6	86	58.8	70.7	82.6	56.3	67.7	79.1	53.6	64.4	75.3	50.7	61.0	71.3	
	67		THC	78.6	78.6	78.6	74.9	74.9	76.3	71.0	71.0	74.6	66.9	66.9	72.8	62.7	62.7	70.8	
			SHC	50.0	64.0	77.9	48.5	62.4	76.3	46.9	60.8	74.6	45.2	59.0	72.8	43.4	57.1	70.8	
	72	THC	85.9	85.9	85.9	81.8	81.8	81.8	77.5	77.5	77.5	73.0	73.0	73.0	68.3	68.3	68.3		
		SHC	35.9	49.9	64	34.4	48.4	62.4	32.9	46.8	60.8	31.3	45.2	59.1	29.6	43.5	57.3		
	76	THC	-	91.8	91.8	-	87.4	87.4	-	82.8	82.8	-	77.9	77.9	-	72.9	72.9		
		SHC	-	38.8	53.2	-	37.3	51.7	-	35.7	50.0	-	34.1	48.3	-	32.4	46.5		

LEGEND:

THC – Total Cooling Capacity, Gross (1000 Btu/h)

SHC – Sensible Cooling Capacity, Gross (1000 Btu/h)

PERFORMANCE DATA

CHS091, FHS091

COOLING COMBINATION RATINGS

CHS091 / FHS091				AMBIENT TEMPERATURE															
				85			95			105			115			125			
				EA (dB)			EA (dB)			EA (dB)			EA (dB)			EA (dB)			
				75	80	85	75	80	85	75	80	85	75	80	85	75	80	85	
2250 Cfm	EA (wB)	58	THC	78.7	78.7	89.2	76.0	76.0	86.1	73.1	73.1	82.8	70.0	70.0	79.3	66.6	66.6	75.4	
			SHC	68.3	78.7	89.2	66	76.0	86.1	63.4	73.1	82.8	60.7	70.0	79.3	57.8	66.6	75.4	
		62	THC	83.6	83.6	83.6	80.1	80.1	81.5	76.3	76.3	79.7	72.3	72.3	77.7	68.0	68.0	75.6	
			SHC	60.9	72.0	83.2	59.3	70.4	81.5	57.5	68.6	79.7	55.7	66.7	77.7	53.6	64.6	75.6	
		67	THC	91.4	91.4	91.4	87.6	87.6	87.6	83.5	83.5	83.5	79.1	79.1	79.1	74.3	74.3	74.3	
			SHC	49.6	60.8	72	48	59.2	70.4	46.4	57.5	68.7	44.6	55.8	66.9	42.7	53.9	65	
	72	THC	99.9	99.9	99.9	95.7	95.7	95.7	91.3	91.3	91.3	86.4	86.4	86.4	81.2	81.2	81.2		
		SHC	37.9	49.3	60.6	36.4	47.7	59.1	34.8	46.1	57.4	33.1	44.4	55.6	31.2	42.5	53.8		
	76	THC	-	107	107	-	103	103	-	97.8	97.8	-	92.6	92.6	-	87.0	87.0		
		SHC	-	39.9	52.2	-	38.4	50.5	-	36.8	48.8	-	35.1	46.9	-	33.3	45		
	2625 Cfm	EA (wB)	58	THC	82.8	82.8	93.8	79.9	79.9	90.5	76.8	76.8	86.9	73.4	73.4	83.1	69.7	69.7	78.9
				SHC	71.8	82.8	93.8	69.3	79.9	90.5	66.6	76.8	86.9	63.6	73.4	83.1	60.5	69.7	78.9
62			THC	86.1	86.1	90.7	82.4	82.4	88.9	78.5	78.5	86.9	74.3	74.3	84.6	69.9	69.9	82.3	
			SHC	65.3	78.0	90.7	63.6	76.2	88.9	61.7	74.3	86.9	59.6	72.1	84.6	57.5	69.9	82.3	
67			THC	94.0	94.0	94.0	90.0	90.0	90.0	85.6	85.6	85.6	81.0	81.0	81.0	76.0	76.0	76.0	
			SHC	52.5	65.3	78.1	50.9	63.7	76.5	49.2	62.0	74.8	47.4	60.2	73	45.5	58.2	71	
72		THC	103	103	103	98.2	98.2	98.2	93.5	93.5	93.5	88.4	88.4	88.4	83.0	83.0	83.0		
		SHC	39.2	52.1	65.1	37.6	50.6	63.5	36	48.9	61.8	34.2	47.1	60	32.4	45.2	58.1		
76		THC	-	110	110	-	105	105	-	100	100	-	94.6	94.6	-	88.7	88.7		
		SHC	-	41.4	55.1	-	39.9	53.5	-	38.3	51.8	-	36.5	50	-	34.7	48		
3000 Cfm		EA (wB)	58	THC	86.2	86.2	97.7	83.1	83.1	94.1	79.8	79.8	90.4	76.2	76.2	86.3	72.2	72.2	81.8
				SHC	74.8	86.2	97.7	72.1	83.1	94.1	69.2	79.8	90.4	66.1	76.2	86.3	62.7	72.2	81.8
	62		THC	88.1	88.1	97.6	84.4	84.4	95.5	80.4	80.4	93	76.3	76.3	89.8	72.3	72.3	85.1	
			SHC	69.3	83.4	97.6	67.4	81.4	95.5	65.3	79.2	93	62.8	76.3	89.8	59.5	72.3	85.1	
	67		THC	96.0	96.0	96.0	91.8	91.8	91.8	87.3	87.3	87.3	82.4	82.4	82.4	77.3	77.3	77.3	
			SHC	55.2	69.6	84	53.6	68.0	82.4	51.8	66.2	80.6	50	64.4	78.7	48.1	62.4	76.8	
	72	THC	105	105	105	100	100	100	95.2	95.2	95.2	89.9	89.9	89.9	84.3	84.3	84.3		
		SHC	40.3	54.9	69.4	38.7	53.3	67.8	37.1	51.6	66.1	35.3	49.8	64.2	33.4	47.9	62.3		
	76	THC	-	112	112	-	107	107	-	102	102	-	96.2	96.2	-	90.1	90.1		
		SHC	-	42.9	58.1	-	41.3	56.4	-	39.7	54.7	-	37.9	52.9	-	36.1	50.9		
	3375 Cfm	EA (wB)	58	THC	89.1	89.1	101	85.8	85.8	97.2	82.3	82.3	93.2	78.5	78.5	88.9	74.4	74.4	84.2
				SHC	77.3	89.1	101	74.5	85.8	97.2	71.4	82.3	93.2	68.1	78.5	88.9	64.5	74.4	84.2
62			THC	90.0	90.0	104	86.1	86.1	101	82.4	82.4	96.9	78.5	78.5	92.4	74.4	74.4	87.6	
			SHC	72.8	88.1	104	70.9	86.1	101	67.8	82.4	96.9	64.7	78.5	92.4	61.3	74.4	87.6	
67			THC	97.6	97.6	97.6	93.2	93.2	93.2	88.6	88.6	88.6	83.6	83.6	84.3	78.2	78.2	82.2	
			SHC	57.8	73.7	89.7	56.1	72.1	88	54.4	70.3	86.2	52.5	68.4	84.3	50.5	66.3	82.2	
72		THC	106	106	106	102	102	102	96.6	96.6	96.6	91.1	91.1	91.1	85.3	85.3	85.3		
		SHC	41.4	57.5	73.6	39.8	55.8	71.9	38.1	54.1	70.1	36.3	52.3	68.3	34.4	50.4	66.3		
76		THC	-	114	114	-	109	109	-	103	103	-	97.4	97.4	-	91.1	91.1		
		SHC	-	44.3	60.9	-	42.7	59.3	-	41.0	57.5	-	39.2	55.7	-	37.4	53.8		
3750 Cfm		EA (wB)	58	THC	91.6	91.6	104	88.1	88.1	99.8	84.5	84.5	95.6	80.5	80.5	91.1	76.1	76.1	86.2
				SHC	79.4	91.6	104	76.5	88.1	99.8	73.3	84.5	95.6	69.8	80.5	91.1	66.1	76.1	86.2
	62		THC	91.7	91.7	108	88.2	88.2	104	84.5	84.5	99.5	80.5	80.5	94.8	76.2	76.2	89.7	
			SHC	75.5	91.7	108	72.6	88.2	104	69.6	84.5	99.5	66.3	80.5	94.8	62.7	76.2	89.7	
	67		THC	98.9	98.9	98.9	94.4	94.4	94.4	89.6	89.6	91.6	84.5	84.5	89.6	79.1	79.1	87.3	
			SHC	60.3	77.8	95.2	58.6	76.1	93.5	56.8	74.2	91.6	54.9	72.2	89.6	52.8	70.0	87.3	
	72	THC	108	108	108	103	103	103	97.7	97.7	97.7	92.1	92.1	92.1	86.1	86.1	86.1		
		SHC	42.4	60.0	77.6	40.8	58.3	75.9	39.1	56.6	74.1	37.2	54.7	72.2	35.3	52.8	70.2		
	76	THC	-	115	115	-	110	110	-	104	104	-	98.4	98.4	-	92.0	92.0		
		SHC	-	45.6	63.7	-	44.0	62.1	-	42.3	60.3	-	40.5	58.4	-	38.6	56.5		

LEGEND:

THC – Total Cooling Capacity, Gross (1000 Btu/h)

SHC – Sensible Cooling Capacity, Gross (1000 Btu/h)

PERFORMANCE DATA

CHS121, FHS120

COOLING COMBINATION RATINGS

CHS121 / FHS120				AMBIENT TEMPERATURE															
				85			95			105			115			125			
				EA (dB)			EA (dB)			EA (dB)			EA (dB)			EA (dB)			
				75	80	85	75	80	85	75	80	85	75	80	85	75	80	85	
3000 Cfm	EA (wB)	58	THC	103	103	116	99.5	99.5	112	95.6	95.6	108	91.2	91.2	103	86.4	86.4	97.4	
			SHC	89.9	103	116	86.8	99.5	112	83.4	95.6	108	79.6	91.2	103	75.4	86.4	97.4	
		62	THC	109	109	110	104	104	108	99.1	99.1	105	93.6	93.6	102	87.7	87.7	98.8	
			SHC	81.2	95.6	110	78.9	93.3	108	76.5	90.8	105	73.8	88.0	102	70.7	84.8	98.8	
		67	THC	119	119	119	114	114	114	108	108	108	102	102	102	95.2	95.2	95.2	
			SHC	66.9	81.4	95.9	64.7	79.2	93.7	62.4	76.8	91.3	59.8	74.2	88.7	57.0	71.4	85.9	
	72	THC	129	129	129	124	124	124	118	118	118	111	111	111	103	103	103		
		SHC	52.1	66.8	81.5	49.9	64.6	79.3	47.6	62.2	76.8	45.0	59.6	74.2	42.3	56.8	71.4		
	76	THC	-	138	138	-	132	132	-	125	125	-	118	118	-	110	110		
		SHC	-	54.9	70.8	-	52.7	68.4	-	50.3	65.8	-	47.7	63.1	-	45.0	60.2		
	3500 Cfm	EA (wB)	58	THC	108	108	122	104	104	118	100	100	113	95.3	95.3	108	90.1	90.1	102
				SHC	94.3	108	122	91.0	104	118	87.3	100	113	83.1	95.3	108	78.6	90.1	102
62			THC	112	112	119	107	107	117	102	102	114	96.1	96.1	110	90.2	90.2	106	
			SHC	86.7	103	119	84.3	101	117	81.7	97.8	114	78.6	94.5	110	74.8	90.2	106	
67			THC	122	122	122	116	116	116	111	111	111	104	104	104	97.0	97.0	97.0	
			SHC	70.6	87.2	104	68.4	84.9	101	65.9	82.4	99	63.3	79.8	96.3	60.5	76.9	93.4	
72		THC	133	133	133	127	127	127	120	120	120	113	113	113	105	105	105		
		SHC	53.7	70.5	87.2	51.5	68.2	84.9	49.0	65.7	82.4	46.4	63.1	79.7	43.7	60.3	76.9		
76		THC	-	142	142	-	135	135	-	128	128	-	120	120	-	112	112		
		SHC	-	56.9	74.6	-	54.6	72.2	-	52.2	69.6	-	49.5	66.9	-	46.8	64.0		
4000 Cfm		EA (wB)	58	THC	112	112	127	108	108	122	104	104	117	98.6	98.6	111	93.0	93.0	105
				SHC	98.0	112	127	94.4	108	122	90.4	104	117	86.0	98.6	111	81.1	93.0	105
	62		THC	114	114	128	109	109	125	104	104	122	98.7	98.7	116	93.1	93.1	109	
			SHC	91.7	110	128	89.0	107	125	86.3	104	122	81.9	98.7	116	77.2	93.1	109	
	67		THC	124	124	124	119	119	119	112	112	112	106	106	106	98.3	98.3	101	
			SHC	74.1	92.6	111	71.8	90.3	109	69.3	87.8	106	66.6	85.1	104	63.7	82.1	101	
	72	THC	135	135	135	129	129	129	122	122	122	114	114	114	107	107	107		
		SHC	55.2	73.9	92.7	52.9	71.6	90.3	50.4	69.1	87.7	47.8	66.4	85	44.9	63.5	82.1		
	76	THC	-	144	144	-	137	137	-	130	130	-	122	122	-	113	113		
		SHC	-	58.8	78.3	-	56.4	75.9	-	53.9	73.3	-	51.3	70.5	-	48.5	67.6		
	4500 Cfm	EA (wB)	58	THC	116	116	131	112	112	126	107	107	120	101	101	114	95.4	95.4	108
				SHC	101	116	131	97.3	112	126	93.0	107	120	88.4	101	114	83.2	95.4	108
62			THC	116	116	136	112	112	131	107	107	125	101	101	119	95.5	95.5	112	
			SHC	96.6	116	136	92.7	112	131	88.6	107	125	84.1	101	119	79.2	95.5	112	
67			THC	126	126	126	120	120	120	114	114	114	107	107	110	99.4	99.4	107	
			SHC	77.4	97.9	118	75.0	95.5	116	72.5	92.9	113	69.7	90.1	110	66.7	86.9	107	
72		THC	137	137	137	130	130	130	123	123	123	116	116	116	108	108	108		
		SHC	56.6	77.2	97.9	54.2	74.8	95.5	51.7	72.3	92.9	49.0	69.5	90.1	46.2	66.6	87.1		
76		THC	-	146	146	-	139	139	-	131	131	-	123	123	-	114	114		
		SHC	-	60.5	82.0	-	58.1	79.5	-	55.6	76.9	-	52.9	74.1	-	50.1	71.1		
5000 Cfm		EA (wB)	58	THC	119	119	134	114	114	129	109	109	123	104	104	117	97.4	97.4	110
				SHC	104	119	134	99.7	114	129	95.3	109	123	90.4	104	117	85	97.4	110
	62		THC	119	119	139	114	114	134	109	109	128	104	104	121	97.5	97.5	114	
			SHC	98.7	119	139	94.9	114	134	90.7	109	128	86.0	104	121	80.9	97.5	114	
	67		THC	128	128	128	122	122	123	115	115	120	108	108	117	100	100	113	
			SHC	80.6	103	125	78.1	101	123	75.5	97.7	120	72.6	94.7	117	69.4	91.4	113	
	72	THC	139	139	139	132	132	132	125	125	125	117	117	117	108	108	108		
		SHC	57.9	80.4	103	55.5	78.0	101	52.9	75.4	97.8	50.2	72.6	95	47.3	69.7	92.0		
	76	THC	-	148	148	-	140	140	-	132	132	-	124	124	-	115	115		
		SHC	-	62.2	85.5	-	59.8	83.0	-	57.2	80.3	-	54.5	77.5	-	51.6	74.5		

LEGEND:

THC – Total Cooling Capacity, Gross (1000 Btu/h)

SHC – Sensible Cooling Capacity, Gross (1000 Btu/h)

PERFORMANCE DATA

CHS180, FHS180

COOLING COMBINATION RATINGS

CHS180 / FHS180				AMBIENT TEMPERATURE															
				85			95			105			115			125			
				EAT (db)			EAT (db)			EAT (db)			EAT (db)			EAT (db)			
				75	80	85	75	80	85	75	80	85	75	80	85	75	80	85	
4500 Cfm	EA (wB)	58	THC	163	163	184	157	157	177	151	151	170	144	144	163	137	137	155	
			SHC	142	163	184	137	157	177	132	151	170	126	144	163	120	137	155	
		62	THC	171	171	174	164	164	170	156	156	167	148	148	162	139	139	158	
			SHC	128	151	174	125	148	170	121	144	167	117	140	162	113	135	158	
		67	THC	187	187	187	179	179	179	171	171	171	162	162	162	152	152	152	
			SHC	106	129	152	102	125	148	98.6	122	145	94.9	118	141	90.8	114	137	
	72	THC	205	205	205	196	196	196	186	186	186	176	176	176	166	166	166		
		SHC	82.4	106	129	79.0	102	125	75.4	98.6	122	71.7	94.8	118	67.7	90.8	114		
	76	THC	-	219	219	-	210	210	-	200	200	-	189	189	-	177	177		
		SHC	-	86.8	111	-	83.4	108	-	79.8	104	-	76.1	100	-	72.1	95.9		
	5250 Cfm	EA (wB)	58	THC	171	171	193	165	165	186	158	158	179	151	151	171	144	144	162
				SHC	149	171	193	144	165	186	138	158	179	132	151	171	125	144	162
62			THC	176	176	190	169	169	186	161	161	181	152	152	176	144	144	168	
			SHC	138	164	190	134	160	186	130	156	181	125	151	176	119	144	168	
67			THC	192	192	192	184	184	184	175	175	175	165	165	165	155	155	155	
			SHC	112	138	165	108	135	161	105	131	157	101	127	153	96.6	123	149	
72		THC	210	210	210	200	200	200	191	191	191	180	180	180	169	169	169		
		SHC	85.1	112	138	81.6	108	135	78.0	105	131	74.2	101	127	70.1	96.6	123		
76		THC	-	224	224	-	215	215	-	204	204	-	193	193	-	180	180		
		SHC	-	90.1	118	-	86.7	114	-	83.0	110	-	79.2	106	-	75.2	102		
6000 Cfm		EA (wB)	58	THC	178	178	201	172	172	193	165	165	186	157	157	177	149	149	168
				SHC	155	178	201	150	172	193	144	165	186	137	157	177	130	149	168
	62		THC	181	181	204	173	173	199	165	165	193	157	157	184	149	149	174	
			SHC	146	175	204	142	170	199	137	165	193	130	157	184	124	149	174	
	67		THC	196	196	196	187	187	187	178	178	178	168	168	168	157	157	161	
			SHC	118	147	177	114	144	173	110	140	170	106	136	166	102	132	161	
	72	THC	214	214	214	204	204	204	194	194	194	183	183	183	171	171	171		
		SHC	87.6	118	147	84.0	114	144	80.3	110	140	76.5	106	136	72.3	102	132		
	76	THC	-	229	229	-	218	218	-	207	207	-	196	196	-	184	184		
		SHC	-	93.2	124	-	89.7	120	-	86.0	117	-	82.2	113	-	78.5	109		
	6750 Cfm	EA (wB)	58	THC	184	184	207	177	177	200	170	170	191	162	162	182	153	153	173
				SHC	161	184	207	154	177	200	148	170	191	141	162	182	134	153	173
62			THC	184	184	216	177	177	207	170	170	199	162	162	189	153	153	179	
			SHC	153	184	216	147	177	207	141	170	199	134	162	189	127	153	179	
67			THC	199	199	199	190	190	190	180	180	181	170	170	177	159	159	173	
			SHC	123	156	189	120	152	185	116	149	181	112	144	177	107	140	173	
72		THC	217	217	217	207	207	207	197	197	197	185	185	185	173	173	173		
		SHC	89.9	123	156	86.3	119	153	82.5	116	149	78.6	112	145	74.4	107	140		
76		THC	-	232	232	-	221	221	-	210	210	-	198	198	-	186	186		
		SHC	-	96.1	130	-	92.6	126	-	88.9	123	-	85.0	119	-	81.2	115		
7500 Cfm		EA (wB)	58	THC	189	189	213	182	182	205	174	174	196	166	166	187	157	157	177
				SHC	165	189	213	159	182	205	152	174	196	145	166	187	137	157	177
	62		THC	189	189	221	182	182	213	174	174	204	166	166	194	157	157	183	
			SHC	157	189	221	151	182	213	144	174	204	138	166	194	130	157	183	
	67		THC	202	202	202	192	192	197	182	182	193	172	172	188	161	161	183	
			SHC	128	165	201	125	161	197	121	157	193	117	152	188	112	147	183	
	72	THC	220	220	220	209	209	209	199	199	199	187	187	187	175	175	175		
		SHC	92.0	128	165	88.4	125	161	84.6	121	157	80.7	117	153	76.5	113	149		
	76	THC	-	235	235	-	224	224	-	212	212	-	200	200	-	188	188		
		SHC	-	98.9	136	-	95.3	132	-	91.6	128	-	87.6	124	-	83.9	120		

LEGEND:

THC – Total Cooling Capacity, Gross (1000 Btu/h)
 SHC – Sensible Cooling Capacity, Gross (1000 Btu/h)

PERFORMANCE DATA

CHS240, FHS240

COOLING COMBINATION RATINGS

CHS240 / FHS240				AMBIENT TEMPERATURE															
				85			95			105			115			125			
				EAT (db)			EAT (db)			EAT (db)			EAT (db)			EAT (db)			
				75	80	85	75	80	85	75	80	85	75	80	85	75	80	85	
6000 Cfm	EA (wb)	58	THC	203	203	229	196	196	221	188	188	212	179	179	202	169	169	191	
			SHC	178	203	229	171	196	221	164	188	212	156	179	202	148	169	191	
		62	THC	213	213	220	204	204	215	193	193	210	182	182	204	171	171	197	
			SHC	162	191	220	157	186	215	152	181	210	147	175	204	140	168	197	
		67	THC	233	233	233	223	223	223	211	211	211	199	199	199	185	185	185	
			SHC	133	163	192	129	158	187	124	153	183	119	148	177	113	142	172	
	72	THC	255	255	255	243	243	243	230	230	230	216	216	216	202	202	202		
		SHC	104	133	163	99	129	158	94.2	124	154	89	119	148	83.6	113	143		
	76	THC	-	272	272	-	260	260	-	246	246	-	231	231	-	215	215		
		SHC	-	109	141	-	105	136	-	100	131	-	94.9	126	-	89.5	120		
	7000 Cfm	EA (wb)	58	THC	214	214	241	206	206	232	197	197	222	187	187	211	177	177	199
				SHC	186	214	241	180	206	232	172	197	222	164	187	211	154	177	199
62			THC	219	219	239	209	209	234	199	199	227	188	188	219	177	177	207	
			SHC	173	206	239	168	201	234	163	195	227	156	188	219	147	177	207	
67			THC	239	239	239	228	228	228	216	216	216	203	203	203	189	189	189	
			SHC	141	174	208	136	170	203	131	165	198	126	159	193	120	154	187	
72		THC	261	261	261	248	248	248	235	235	235	220	220	220	205	205	205		
		SHC	107	141	175	102	136	170	97.3	131	165	92	126	160	86.5	120	154		
76		THC	-	279	279	-	265	265	-	251	251	-	235	235	-	219	219		
		SHC	-	114	149	-	109	144	-	104	139	-	98.7	134	-	93.2	128		
8000 Cfm		EA (wb)	58	THC	222	222	250	214	214	241	204	204	230	194	194	218	182	182	205
				SHC	194	222	250	186	214	241	178	204	230	169	194	218	159	182	205
	62		THC	225	225	256	214	214	251	204	204	239	194	194	227	182	182	213	
			SHC	183	219	256	178	214	251	170	204	239	161	194	227	151	182	213	
	67		THC	244	244	244	232	232	232	219	219	219	206	206	208	191	191	202	
			SHC	148	186	223	143	181	219	138	176	213	133	170	208	127	164	202	
	72	THC	265	265	265	252	252	252	239	239	239	224	224	224	208	208	208		
		SHC	110	148	186	105	143	181	100	138	176	94.8	133	170	89.2	127	165		
	76	THC	-	283	283	-	270	270	-	255	255	-	239	239	-	222	222		
		SHC	-	117	157	-	113	152	-	108	147	-	102	141	-	96.8	136		
	9000 Cfm	EA (wb)	58	THC	229	229	258	220	220	248	210	210	236	199	199	224	187	187	211
				SHC	200	229	258	192	220	248	183	210	236	174	199	224	163	187	211
62			THC	229	229	268	220	220	257	210	210	246	199	199	233	187	187	219	
			SHC	191	229	268	183	220	257	174	210	246	165	199	233	155	187	219	
67			THC	247	247	247	235	235	235	222	222	228	208	208	222	193	193	215	
			SHC	155	196	238	150	192	233	145	186	228	139	180	222	133	174	215	
72		THC	269	269	269	256	256	256	241	241	241	226	226	226	210	210	210		
		SHC	113	155	197	108	150	192	103	145	187	97.4	139	181	91.8	133	175		
76		THC	-	287	287	-	273	273	-	258	258	-	241	241	-	-	-		
		SHC	-	121	165	-	116	160	-	111	154	-	106	149	-	-	-		
10000 Cfm		EA (wb)	58	THC	235	235	265	225	225	254	215	215	242	203	203	229	191	191	215
				SHC	205	235	265	197	225	254	188	215	242	178	203	229	167	191	215
	62		THC	235	235	275	225	225	264	215	215	251	203	203	238	191	191	223	
			SHC	195	235	275	187	225	264	179	215	251	169	203	238	159	191	223	
	67		THC	250	250	252	238	238	247	224	224	241	210	210	235	195	195	227	
			SHC	161	207	252	156	202	247	151	196	241	145	190	235	138	183	227	
	72	THC	272	272	272	258	258	258	244	244	244	228	228	228	212	212	212		
		SHC	115	161	207	111	156	202	105	151	197	99.9	146	191	94.2	140	185		
	76	THC	-	290	290	-	276	276	-	260	260	-	-	-	-	-	-		
		SHC	-	125	172	-	120	167	-	115	161	-	-	-	-	-	-		

LEGEND:

THC – Total Cooling Capacity, Gross (1000 Btu/h)

SHC – Sensible Cooling Capacity, Gross (1000 Btu/h)

PERFORMANCE DATA

CHS072, FHS072

HEATING COMBINATION RATINGS

CHS072 / FHS072			Temperature Air Entering Outdoor Coil (°F db at 70% rh)								
Return Air (°F db)	CFM (Standard Air)		-10	0	10	17	30	40	47	50	60
			55	1800	TH	21.4	27.7	34.5	39.7	50.1	58.6
THI	19.7	25.5			31.6	36.2	43.9	55.9	64.4	67.0	75.6
kW	2.33	2.60			2.89	3.12	3.60	4.01	4.29	4.43	4.91
2400	TH	22.0		28.5	35.5	40.9	51.6	60.0	65.6	68.0	76.3
	THI	27.6		27.6	27.5	27.4	26.3	28.7	30.0	30.0	30.0
	kW	2.27		2.51	2.77	2.96	3.37	3.70	3.93	4.04	4.41
3000	TH	22.4		29.0	36.2	41.6	52.5	60.6	65.9	68.3	76.2
	THI	20.6		26.7	33.1	37.9	46.0	57.9	65.9	68.3	76.2
	kW	2.23		2.45	2.68	2.86	3.23	3.50	3.71	3.80	4.11
65	1800	TH	19.1	25.4	32.2	37.3	47.6	56.4	62.4	65.1	73.8
		THI	17.5	23.3	29.5	34.0	41.7	53.9	62.4	65.1	73.8
		kW	2.57	2.86	3.18	3.43	3.95	4.42	4.73	4.87	5.39
	2400	TH	19.6	26.1	33.2	38.5	49.2	58.0	64.0	66.5	75.0
		THI	18.1	24.0	30.4	35.1	43.1	55.4	64.0	66.5	75.0
		kW	2.51	2.78	3.06	3.28	3.73	4.11	4.36	4.48	4.90
	3000	TH	20.0	26.6	33.8	39.2	50.2	59.0	64.7	67.1	75.4
		THI	18.4	24.5	31.0	35.8	44.0	56.3	64.7	67.1	75.4
		kW	2.47	2.72	2.98	3.18	3.58	3.91	4.13	4.24	4.59
70	1800	TH	17.8	24.1	31.0	36.1	46.4	55.2	61.3	64.0	72.8
		THI	16.4	22.2	28.4	32.9	40.6	52.7	61.3	64.0	72.8
		kW	2.69	2.99	3.33	3.59	4.13	4.62	4.95	5.09	5.63
	2400	TH	18.4	24.9	32.0	37.3	48.0	57.0	63.0	65.6	74.2
		THI	16.9	22.9	29.3	34.0	42.0	54.4	63.0	65.6	74.2
		kW	2.64	2.91	3.21	3.44	3.91	4.32	4.58	4.70	5.14
	3000	TH	18.7	25.4	32.6	38.0	49.0	57.9	63.9	66.4	74.7
		THI	17.2	23.3	29.8	34.7	42.9	55.3	63.9	66.4	74.7
		kW	2.60	2.86	3.14	3.34	3.77	4.12	4.35	4.46	4.83
80	1800	TH	15.3	21.5	28.4	33.5	43.8	52.5	58.9	61.5	70.6
		THI	14.1	19.8	26.0	30.6	38.4	50.1	58.9	61.5	70.6
		kW	2.93	3.27	3.64	3.92	4.50	5.02	5.41	5.56	6.13
	2400	TH	15.8	22.3	29.4	34.7	45.3	54.4	60.8	63.5	72.4
		THI	14.5	20.5	26.9	31.6	39.7	52.0	60.8	63.5	72.4
		kW	2.89	3.19	3.52	3.77	4.28	4.73	5.03	5.16	5.65
	3000	TH	16.1	22.7	30.0	35.4	46.3	55.6	61.9	64.6	73.2
		THI	14.8	20.9	27.5	32.3	40.6	53.1	61.9	64.6	73.2
		kW	2.86	3.14	3.45	3.68	4.14	4.54	4.80	4.92	5.34

LEGEND:

- TH** – Total Heating Capacity, Gross (1000 Btu/h)
- THI** – Integrated Heating Capacity, Gross (1000 Btu/h)
- kW** – Total Compressor Power Motor Input

PERFORMANCE DATA

CHS091, FHS091

HEATING COMBINATION RATINGS

CHS091 / FHS091			Temperature Air Entering Outdoor Coil (°F db at 70% rh)								
Return Air (°F db)	CFM (Standard Air)		-10	0	10	17	30	40	47	50	60
			55	2250	TH	31.6	39.6	47.8	53.8	66.9	78.2
THI	29.1	36.4			43.8	49.0	58.6	74.7	86.1	89.6	101
kW	3.83	4.14			4.45	4.67	5.18	5.65	5.96	6.08	6.53
3000	TH	32.2		40.5	48.8	55.0	69.4	80.1	88.0	91.4	102
	THI	29.7		37.2	44.7	50.2	60.8	76.5	88.0	91.4	102
	kW	3.70		3.96	4.22	4.42	4.87	5.23	5.44	5.54	5.90
3750	TH	32.6		40.9	49.4	55.8	70.3	81.2	88.8	92.1	103
	THI	30.0		37.6	45.3	50.9	61.6	77.5	88.8	92.1	103
	kW	3.62		3.86	4.09	4.26	4.67	4.97	5.15	5.23	5.54
65	2250	TH	29.5	37.4	45.6	51.4	63.7	75.8	83.8	87.4	98.6
		THI	27.1	34.4	41.8	46.9	55.8	72.4	83.8	87.4	98.6
		kW	4.24	4.56	4.90	5.14	5.65	6.19	6.55	6.67	7.15
	3000	TH	30.2	38.3	46.7	52.7	65.8	77.8	85.8	89.2	100
		THI	27.7	35.2	42.8	48.1	57.7	74.3	85.8	89.2	100
		kW	4.12	4.40	4.68	4.88	5.32	5.75	6.00	6.10	6.48
	3750	TH	30.6	38.8	47.3	53.5	67.3	78.9	86.7	90.0	101
		THI	28.1	35.7	43.4	48.8	59.0	75.4	86.7	90.0	101
		kW	4.04	4.29	4.54	4.72	5.12	5.50	5.68	5.77	6.10
70	2250	TH	28.3	36.2	44.4	50.3	62.3	73.7	82.5	86.2	97.4
		THI	26.0	33.3	40.6	45.9	54.6	70.3	82.5	86.2	97.4
		kW	4.45	4.79	5.14	5.39	5.91	6.43	6.87	6.99	7.48
	3000	TH	28.9	37.1	45.5	51.4	64.2	76.6	84.6	88.1	98.9
		THI	26.6	34.1	41.7	46.9	56.2	73.1	84.6	88.1	98.9
		kW	4.33	4.62	4.92	5.12	5.57	6.03	6.29	6.40	6.79
	3750	TH	29.4	37.6	46.2	52.2	65.5	77.8	85.6	89.0	99.6
		THI	27.0	34.6	42.3	47.6	57.4	74.3	85.6	89.0	99.6
		kW	4.26	4.52	4.78	4.97	5.37	5.77	5.97	6.06	6.40
80	2250	TH	25.6	33.6	41.8	47.7	59.5	70.2	79.4	83.6	95.1
		THI	23.6	30.9	38.3	43.5	52.1	67.0	79.4	83.6	95.1
		kW	4.89	5.26	5.64	5.92	6.47	6.99	7.49	7.67	8.19
	3000	TH	26.3	34.5	42.9	49.0	61.2	72.7	82.1	85.7	96.6
		THI	24.2	31.7	39.3	44.7	53.6	69.5	82.1	85.7	96.6
		kW	4.78	5.10	5.42	5.65	6.12	6.57	6.93	7.05	7.46
	3750	TH	26.7	35.0	43.6	49.8	62.3	74.7	83.3	86.7	97.3
		THI	24.5	32.2	39.9	45.4	54.6	71.3	83.3	86.7	97.3
		kW	4.71	5.00	5.29	5.50	5.90	6.33	6.59	6.69	7.04

LEGEND:

TH – Total Heating Capacity, Gross (1000 Btu/h)

THI – Integrated Heating Capacity, Gross (1000 Btu/h)

kW – Total Compressor Power Motor Input

PERFORMANCE DATA

CHS121, FHS120

HEATING COMBINATION RATINGS

CHS121 / FHS120			Temperature Air Entering Outdoor Coil (°F db at 70% rh)								
Return Air (°F db)	CFM (Standard Air)		-10	0	10	17	30	40	47	50	60
			55	3000	TH	35.9	46.0	56.1	64.2	81.1	96.6
THI	33.1	42.3			51.4	58.5	71.0	92.3	106	110	123
kW	4.46	4.83			5.18	5.45	6.03	6.59	6.83	6.95	7.37
4000	TH	36.8		46.8	57.2	65.4	83.0	97.9	107	110	123
	THI	33.8		43.0	52.4	59.7	72.7	93.5	107	110	123
	kW	4.34		4.66	4.96	5.19	5.67	6.08	6.28	6.37	6.70
5000	TH	37.2		47.4	57.9	66.2	84.8	98.3	107	110	123
	THI	34.2		43.5	53.0	60.3	74.3	93.9	107	110	123
	kW	4.26		4.55	4.82	5.03	5.50	5.79	5.96	6.04	6.31
65	3000	TH	32.5	43.0	53.3	61.2	77.9	92.9	104	108	120
		THI	29.9	39.5	48.8	55.9	68.2	88.7	104	108	120
		kW	4.94	5.36	5.75	6.05	6.66	7.24	7.58	7.71	8.15
	4000	TH	33.3	44.0	54.4	62.5	79.5	95.7	105	108	121
		THI	30.7	40.4	49.8	57.0	69.7	91.3	105	108	121
		kW	4.83	5.19	5.52	5.78	6.29	6.79	6.99	7.09	7.44
	5000	TH	33.8	44.6	55.0	63.3	80.7	96.3	105	109	121
		THI	31.1	41.0	50.4	57.7	70.7	92.0	105	109	121
		kW	4.76	5.09	5.39	5.61	6.07	6.47	6.65	6.74	7.03
70	3000	TH	30.7	41.4	51.9	59.7	76.3	90.9	102	107	119
		THI	28.3	38.0	47.5	54.4	66.8	86.8	102	107	119
		kW	5.20	5.64	6.06	6.36	7.00	7.57	7.98	8.11	8.57
	4000	TH	31.5	42.3	52.9	61.0	78.0	93.5	104	107	120
		THI	29.0	38.9	48.5	55.6	68.3	89.3	104	107	120
		kW	5.09	5.47	5.83	6.09	6.62	7.14	7.38	7.48	7.84
	5000	TH	32.0	42.9	53.5	61.8	79.0	95.2	104	108	120
		THI	29.4	39.4	49.1	56.3	69.2	90.9	104	108	120
		kW	5.02	5.37	5.69	5.93	6.39	6.85	7.03	7.11	7.41
80	3000	TH	26.9	37.8	49.0	56.6	73.0	86.9	98.3	103	117
		THI	24.8	34.8	44.9	51.6	63.9	83.0	98.3	103	117
		kW	5.75	6.23	6.72	7.04	7.73	8.32	8.85	8.98	9.46
	4000	TH	27.6	38.7	50.1	57.8	74.7	89.4	101	105	118
		THI	25.4	35.6	45.9	52.7	65.4	85.3	101	105	118
		kW	5.65	6.08	6.49	6.76	7.35	7.84	8.21	8.32	8.69
	5000	TH	28.0	39.3	50.6	58.5	75.7	90.8	102	106	118
		THI	25.8	36.1	46.3	53.4	66.3	86.8	102	106	118
		kW	5.59	5.98	6.35	6.60	7.11	7.57	7.84	7.93	8.24

LEGEND:

- TH – Total Heating Capacity, Gross (1000 Btu/h)
- THI – Integrated Heating Capacity, Gross (1000 Btu/h)
- kW – Total Compressor Power Motor Input

PERFORMANCE DATA

CHS180, FHS180

HEATING COMBINATION RATINGS

CHS180 / FHS180			Temperature Air Entering Outdoor Coil (°F db at 70% rh)									
Return Air (°F db)	CFM (Standard Air)		-10	0	10	17	20	30	40	47	50	60
			55	4500	TH	61.6	78.2	95.0	107	42	134	157
THI	56.7	71.9			87.1	97.9	37.8	117	150	173	180	203
kW	7.30	7.90			8.51	8.95	3.22	9.95	10.9	11.6	11.9	12.8
6000	TH	63.1		80.2	97.5	110	43	140	161	178	185	207
	THI	58.0		73.7	89.4	101	27	122	154	178	185	207
	kW	7.06		7.57	8.09	8.47	3.05	9.39	10.1	10.6	10.8	11.6
7500	TH	64.0		81.4	99.0	112	44	142	164	180	187	209
	THI	58.9		74.8	90.7	102	40	124	157	180	187	209
	kW	6.91		7.37	7.83	8.17	2.94	9.00	9.66	10.0	10.2	10.9
65	4500	TH	56.3	72.8	89.8	102	40	127	151	168	175	199
		THI	51.8	66.9	82.3	93	36	111	144	168	175	199
		kW	8.06	8.70	9.36	9.84	3.55	10.8	11.9	12.7	13.0	14.0
	6000	TH	58.0	75.0	92.5	105	41	132	156	173	180	203
		THI	53.4	68.9	84.7	95.8	37	115	149	173	180	203
		kW	7.83	8.38	8.94	9.34	3.37	10.2	11.1	11.7	11.9	12.7
	7500	TH	59.0	76.3	94.0	107	42	135	159	175	182	205
		THI	54.3	70.1	86.1	97.5	37.6	118	152	175	182	205
		kW	7.69	8.18	8.68	9.04	3.27	9.83	10.6	11.1	11.3	12.0
70	4500	TH	53.4	69.9	86.9	99.1	38.4	124	146	165	173	196
		THI	49.1	64.2	79.6	90.4	34.6	108	140	165	173	196
		kW	8.45	9.12	9.81	10.3	3.7	11.3	12.4	13.3	13.6	14.7
	6000	TH	55.1	72.1	89.6	102	40	128	154	170	177	201
		THI	50.6	66.3	82.1	93.1	35.8	112	147	170	177	201
		kW	8.23	8.81	9.39	9.81	3.54	10.7	11.6	12.3	12.5	13.3
	7500	TH	56.1	73.5	91.3	104	40	131	156	173	180	203
		THI	51.6	67.5	83.6	95	36	115	149	173	180	203
		kW	8.09	8.61	9.13	9.50	3.43	10.3	11.1	11.6	11.8	12.5
80	4500	TH	47.1	63.6	80.7	93.1	35.8	117	139	157	166	191
		THI	43.3	58.5	73.9	84.9	32.3	103	133	157	166	191
		kW	9.27	10.0	10.8	11.3	4.04	12.4	13.4	14.4	14.9	16.1
	6000	TH	48.7	65.8	83.4	96.2	37.0	121	145	164	172	196
		THI	44.8	60.5	76.4	87.8	33.4	106	138	164	172	196
		kW	9.06	9.70	10.3	10.8	3.9	11.7	12.6	13.5	13.8	14.6
	7500	TH	49.6	67.1	85.1	98.1	37.8	124	148	167	175	198
		THI	45.7	61.7	77.9	89.5	34.1	109	142	167	175	198
		kW	8.94	9.51	10.1	10.5	8.9	11.3	12.1	12.9	13.0	13.8

LEGEND:

TH – Total Heating Capacity, Gross (1000 Btu/h)

THI – Integrated Heating Capacity, Gross (1000 Btu/h)

kW – Total Compressor Power Motor Input

PERFORMANCE DATA

CHS240, FHS240

HEATING COMBINATION RATINGS

CHS240 / FHS240			Air Temperature Entering Outdoor Coil (°F)									
Return Air (°F db)	CFM (Standard Air)		-10	0	10	17	20	30	40	47	50	60
			55	6000	TH	75.5	95.1	115.7	131.2	138.3	164.3	193.4
THI	69.5	87.4			106.0	119.7	124.8	144.0	184.7	215.2	225.6	263.6
kW	8.28	8.97			9.64	10.08	10.27	10.98	11.80	12.44	12.76	13.96
8000	TH	77.0		96.8	117.7	133.4	140.6	167.1	196.7	218.9	229.5	268.3
	THI	27.6		27.6	27.5	27.4	27.1	26.3	28.7	30.0	30.0	30.0
	kW	8.05		8.65	9.21	9.58	9.74	10.35	11.03	11.56	11.82	12.81
10000	TH	77.9		97.7	118.8	134.6	141.9	168.7	198.7	221.1	231.7	271.0
	THI	71.6		89.8	108.8	122.8	128.0	147.8	189.7	221.1	231.7	271.0
	kW	7.91		8.45	8.96	9.29	9.43	9.98	10.58	11.05	11.28	12.15
65	6000	TH	69.3	89.6	110.5	125.9	133.0	159.0	187.8	209.6	220.1	257.8
		THI	63.7	82.3	101.2	114.8	119.9	139.3	179.4	209.6	220.1	257.8
		kW	9.16	9.94	10.68	11.16	11.37	12.14	13.02	13.71	14.05	15.32
	8000	TH	70.8	91.3	112.5	128.2	135.4	161.9	191.3	213.5	224.2	262.8
		THI	65.2	83.9	103.1	116.9	122.1	141.8	182.7	213.5	224.2	262.8
		kW	8.93	9.61	10.24	10.66	10.83	11.49	12.23	12.79	13.07	14.11
	10000	TH	71.7	92.4	113.7	129.5	136.8	163.5	193.4	215.8	226.5	265.6
		THI	66.0	84.9	104.1	118.1	123.4	143.2	184.7	215.8	226.5	265.6
		kW	8.80	9.42	9.99	10.36	10.52	11.11	11.75	12.25	12.49	13.41
70	6000	TH	66.0	86.8	107.7	123.1	130.1	156.2	184.8	206.8	217.2	254.9
		THI	60.7	79.8	98.7	112.3	117.4	136.8	176.5	206.8	217.2	254.9
		kW	9.63	10.47	11.24	11.75	11.96	12.76	13.68	14.39	14.74	16.05
	8000	TH	67.5	88.5	109.8	125.4	132.6	159.1	188.5	210.7	221.3	259.8
		THI	62.1	81.3	100.5	114.4	119.6	139.4	180.0	210.7	221.3	259.8
		kW	9.40	10.13	10.79	11.22	11.41	12.09	12.86	13.44	13.73	14.80
	10000	TH	68.4	89.5	111.0	126.7	134.0	160.8	190.6	213.0	223.8	262.7
		THI	63.0	82.2	101.6	115.6	120.9	140.9	182.0	213.0	223.8	262.7
		kW	9.27	9.93	10.53	10.92	11.09	11.70	12.39	12.90	13.15	14.09
80	6000	TH	58.8	80.3	101.9	117.2	124.2	150.1	178.6	200.6	211.0	248.6
		THI	54.1	73.8	93.4	106.9	112.0	131.5	170.6	200.6	211.0	248.6
		kW	10.62	11.58	12.45	12.99	13.23	14.09	15.08	15.85	16.23	17.63
	8000	TH	60.3	82.2	104.0	119.6	126.7	153.2	182.3	204.7	215.3	253.7
		THI	55.5	75.5	95.3	109.0	114.3	134.2	174.1	204.7	215.3	253.7
		kW	10.40	11.24	11.99	12.46	12.66	13.40	14.24	14.87	15.17	16.31
	10000	TH	61.2	83.3	105.2	120.9	128.1	154.9	184.4	207.1	217.8	256.7
		THI	56.3	76.6	96.3	110.3	115.6	135.7	176.1	207.1	217.8	256.7
		kW	10.27	11.04	11.72	12.14	12.32	12.99	13.73	14.27	14.54	15.55

LEGEND:

- TH** – Total Heating Capacity, Gross (1000 Btu/h)
- THI** – Integrated Heating Capacity, Gross (1000 Btu/h)
- kW** – Total Compressor Power Motor Input

TYPICAL WIRING SCHEMATIC: CHS121 (460-3-60 Shown)

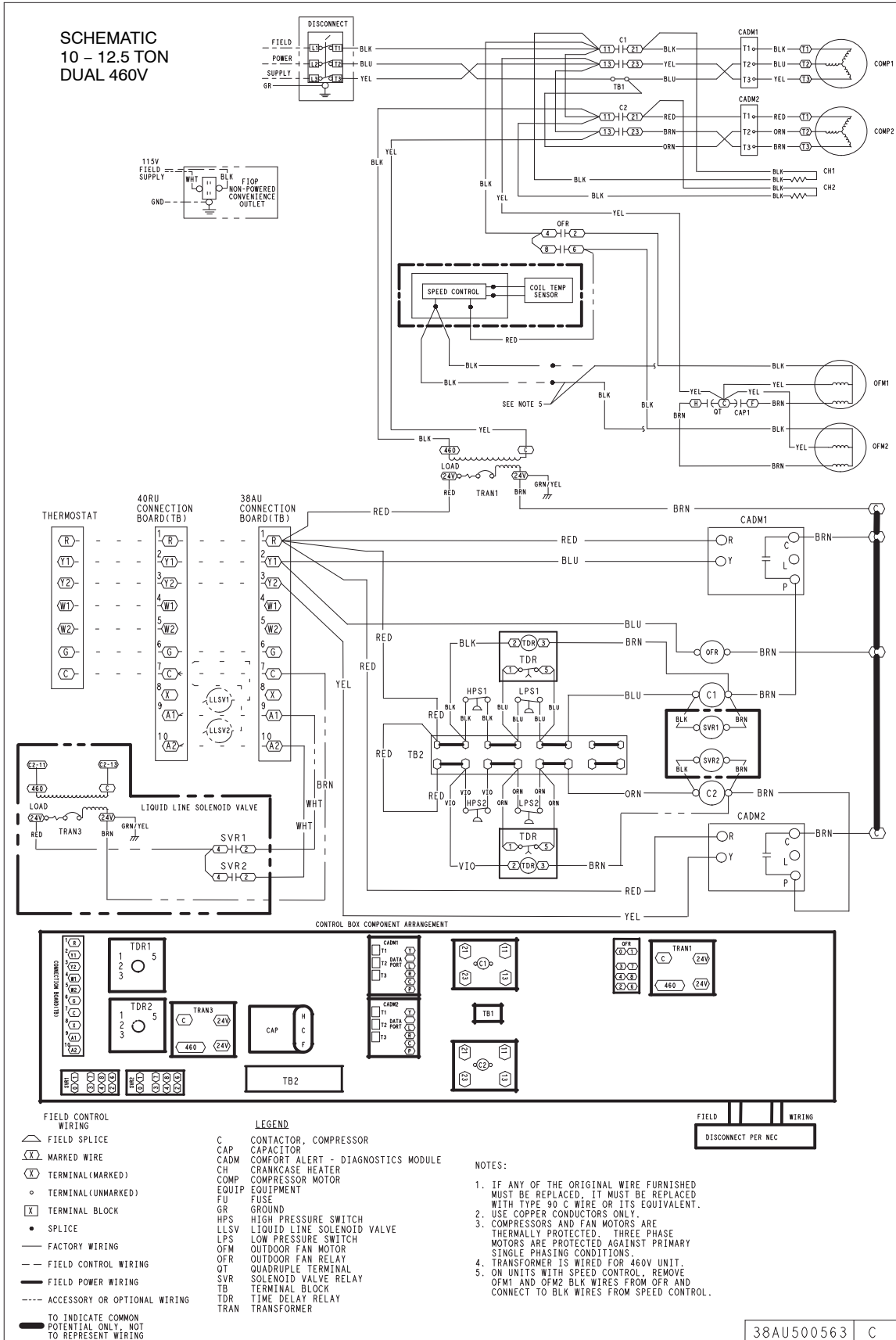

TYPICAL WIRING SCHEMATIC: CHS180 (208/230-3-60 Shown)

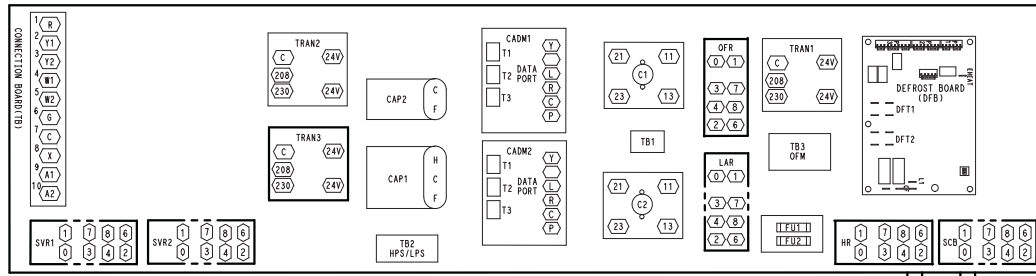

COMPONENT ARRANGEMENT

FIELD CONTROL WIRING

- △ FIELD SPLICE
- ⓧ MARKED WIRE
- ⓧ TERMINAL (MARKED)
- TERMINAL (UNMARKED)
- TERMINAL BLOCK
- SPLICE
- FACTORY WIRING
- - - FIELD CONTROL WIRING
- FIELD POWER WIRING
- - - ACCESSORY OR OPTIONAL WIRING
- TO INDICATE COMMON POTENTIAL ONLY, NOT TO REPRESENT WIRING

LEGEND

- C CONTACTOR, COMPRESSOR
- CAP CAPACITOR
- CH CRANKCASE HEATER
- CAM COMFORT ALERT - DIAGNOSTICS MODULE
- COMP COMPRESSOR MOTOR
- DFB DEFROST BOARD
- DFT DEFROST THERMOSTAT
- EQIP EQUIPMENT
- FPT FREEZE PROTECTION THERMOSTAT
- FU FUSE
- GR GROUND
- HPS HIGH PRESSURE SWITCH
- HR HEATER RELAY
- LAR LOW AMBIENT RELAY
- LAS LOW AMBIENT SWITCH
- LLEV LIQUID LINE SOLENOID VALVE
- LOC LOSS OF CHARGE SWITCH
- OFM OUTDOOR FAN MOTOR
- OT QUADRUPEL TERMINAL
- RVS REVERSING VALVE SOLENOID
- SCB SPEED CONTROL BYPASS
- SVR SOLENOID VALVE RELAY
- TB TERMINAL BLOCK
- TRAN TRANSFORMER

NOTES:

1. IF ANY OF THE ORIGINAL WIRE FURNISHED MUST BE REPLACED, IT MUST BE REPLACED WITH TYPE 90 C WIRE OR ITS EQUIVALENT.
2. USE COPPER CONDUCTORS ONLY.
3. COMPRESSORS AND FAN MOTORS ARE THERMALLY PROTECTED. THREE PHASE MOTORS ARE PROTECTED AGAINST PRIMARY SINGLE PHASING CONDITIONS.
4. TRANSFORMER IS WIRED FOR 230V UNIT. IF UNIT IS TO BE RUN WITH 208V POWER SUPPLY, DISCONNECT BLK WIRE FROM 230V TAP AND CONNECT TO 208V TAP.
5. ON UNITS WITH SPEED CONTROL, REMOVE BLK WIRE FROM OFM1 & 3 AT TB3 AND RECONNECT TO SCB TERMINAL 2 HARNESS.



SCHEMATIC
208/230V 15T DUAL HP

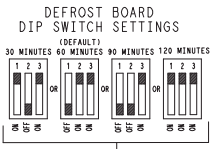
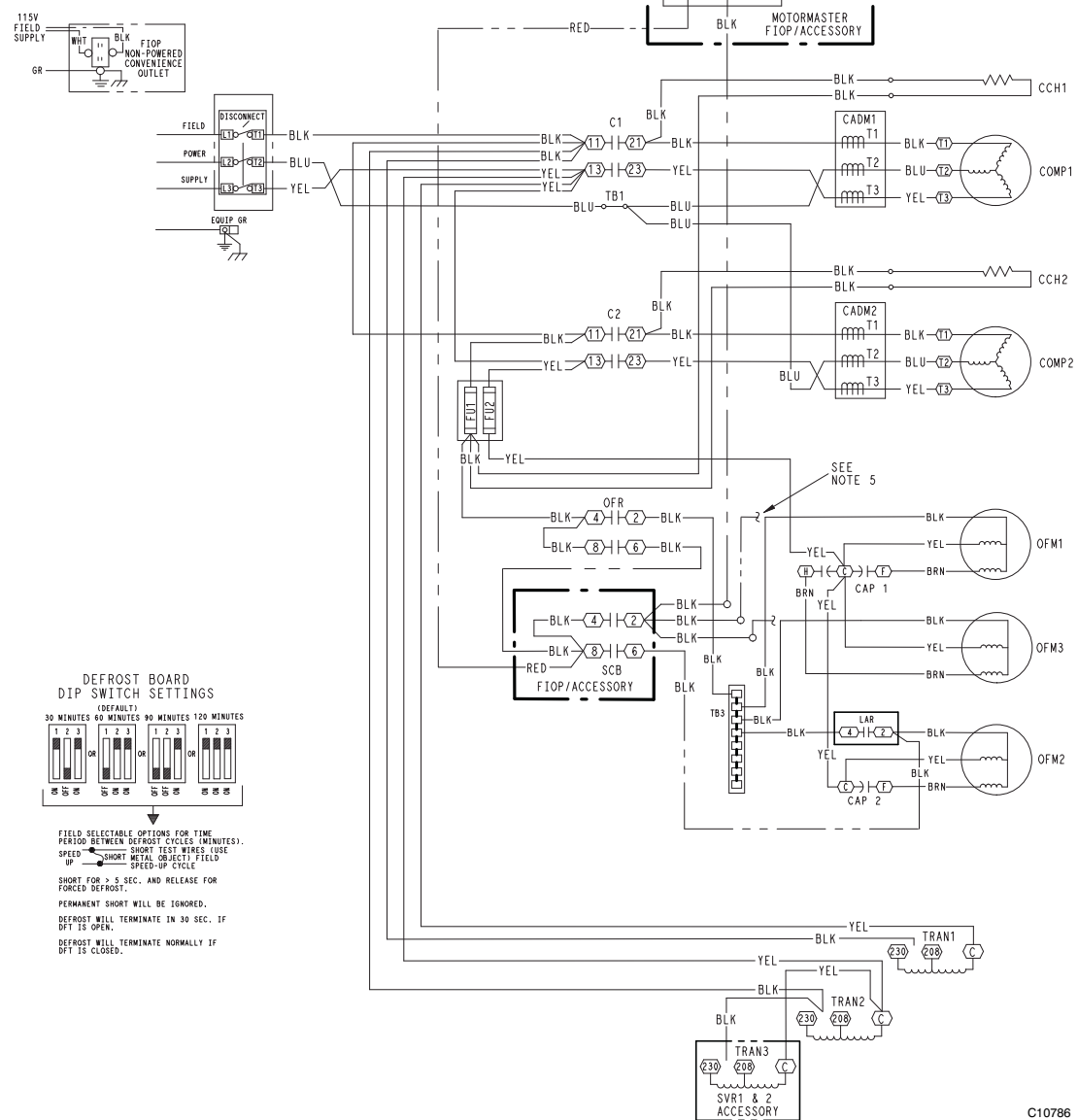

FIELD SELECTABLE OPTIONS FOR TIME PERIOD BETWEEN DEFROST CYCLES (MINUTES).
 SHORT TEST WIRE: USE SPEED UP SHORT METAL OBJECT: FIELD SPEED-UP CYCLE
 SHORT FOR > 5 SEC. AND RELEASE FOR FORCED DEFROST.
 PERMANENT SHORT WILL BE IGNORED.
 DEFROST WILL TERMINATE IN 30 SEC. IF DFT IS OPEN.
 DEFROST WILL TERMINATE NORMALLY IF DFT IS CLOSED.

C10786

TYPICAL WIRING SCHEMATIC: CHS240 (208/230-3-60 Shown)

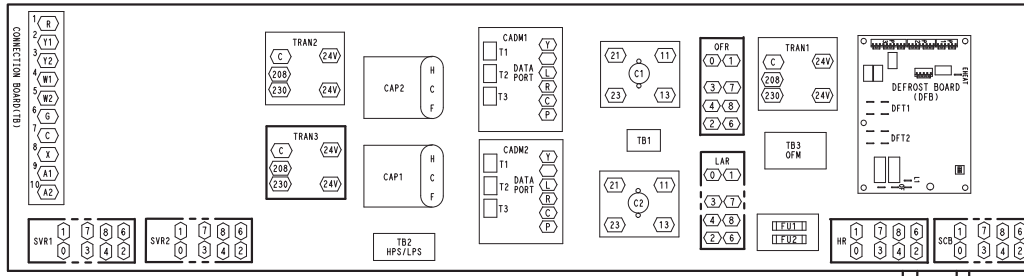

COMPONENT ARRANGEMENT

- FIELD CONTROL WIRING**
- △ FIELD SPlice
 - Ⓜ MARKED WIRE
 - Ⓧ TERMINAL (MARKED)
 - TERMINAL (UNMARKED)
 - Ⓛ TERMINAL BLOCK
 - SPlice
 - FACTORY WIRING
 - - - FIELD CONTROL WIRING
 - FIELD POWER WIRING
 - · - · - ACCESSORY OR OPTIONAL WIRING
 - TO INDICATE COMMON POTENTIAL ONLY, NOT TO REPRESENT WIRING

- LEGEND**
- C CONTACTOR, COMPRESSOR
 - CAP CAPACITOR
 - CH CRANKCASE HEATER
 - COM CONTACT ALERT - DIAGNOSTICS MODULE
 - COMP COMPRESSOR MOTOR
 - DFB DEFROST BOARD
 - DFT DEFROST THERMOSTAT
 - EQUIP EQUIPMENT
 - FPT FREEZE PROTECTION THERMOSTAT
 - FU FUSE
 - GR GROUND
 - HR HEATER RELAY
 - HPS HIGH PRESSURE SWITCH
 - LAR LOW AMBIENT RELAY
 - LAS LOW AMBIENT SWITCH
 - LSV LIQUID LINE SOLENOID VALVE
 - LIC LOSS OF CHARGE SWITCH
 - GM OUTDOOR FAN MOTOR
 - OFR OUTDOOR FAN RELAY
 - RVS REVERSING VALVE SOLENOID
 - SCB SPEED CONTROL BYPASS
 - SVR SOLENOID VALVE RELAY
 - TB TERMINAL BLOCK
 - TRAN TRANSFORMER

- NOTES:**
1. IF ANY OF THE ORIGINAL WIRE FURNISHED MUST BE REPLACED, IT MUST BE REPLACED WITH TYPE 90 C WIRE OR ITS EQUIVALENT.
 2. USE COPPER CONDUCTORS ONLY.
 3. COMPRESSORS AND FAN MOTORS ARE THE SMALLER PROTECTED. THREE PHASE MOTORS ARE PROTECTED AGAINST PRIMARY SINGLE PHASING CONDITIONS.
 4. TRANSFORMER IS WIRED FOR 230V UNIT. IF UNIT IS TO BE RUN WITH 208V POWER SUPPLY, DISCONNECT BLK WIRE FROM 230V TAP AND CONNECT TO 208V TAP.
 5. ON UNITS WITH SPEED CONTROL, REMOVE BLK WIRE FROM OFM1 & 3 AT TB3 AND RECONNECT TO SCB TERMINAL 2 HARNESS.

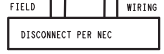

SCHEMATIC
208/230V 20T DUAL HP

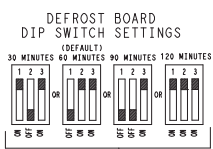
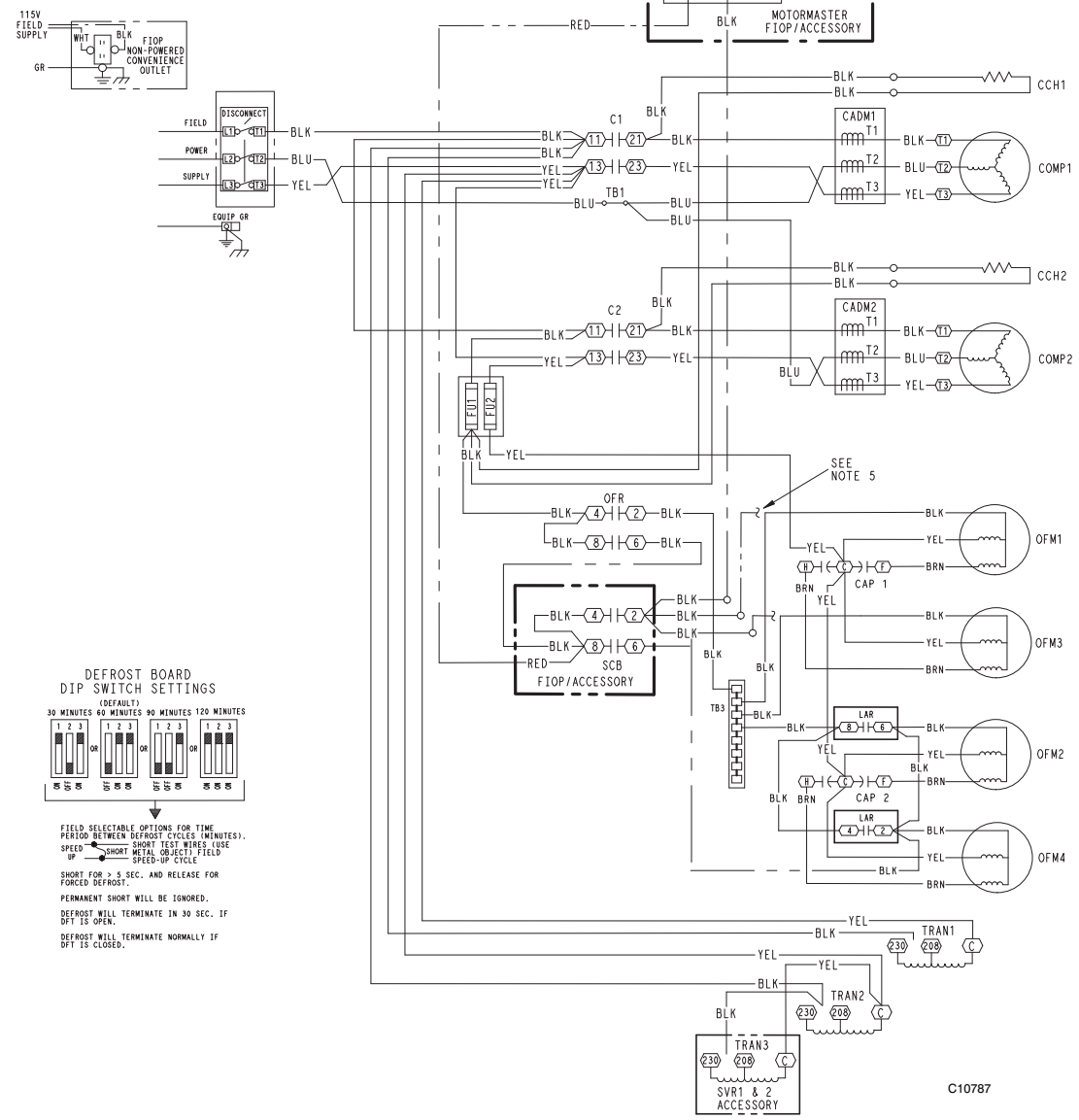

FIELD SELECTABLE OPTIONS FOR TIME PERIOD BETWEEN DEFROST CYCLES (MINUTES).

SPEED ← SHORT TEST WIRES (USE SHORT METAL OBJECT) FIELD → SPEED-UP CYCLE

SHORT FOR > 5 SEC. AND RELEASE FOR FORCED DEFROST.

PERMANENT SHORT WILL BE IGNORED.

DEFROST WILL TERMINATE IN 30 SEC. IF DFT IS OPEN.

DEFROST WILL TERMINATE NORMALLY IF DFT IS CLOSED.

C10787

TYPICAL WIRING SCHEMATIC: CHS180-240 CONTROL SCHEMATIC

CONTROL SCHEMATIC
15, 20T DUAL HP

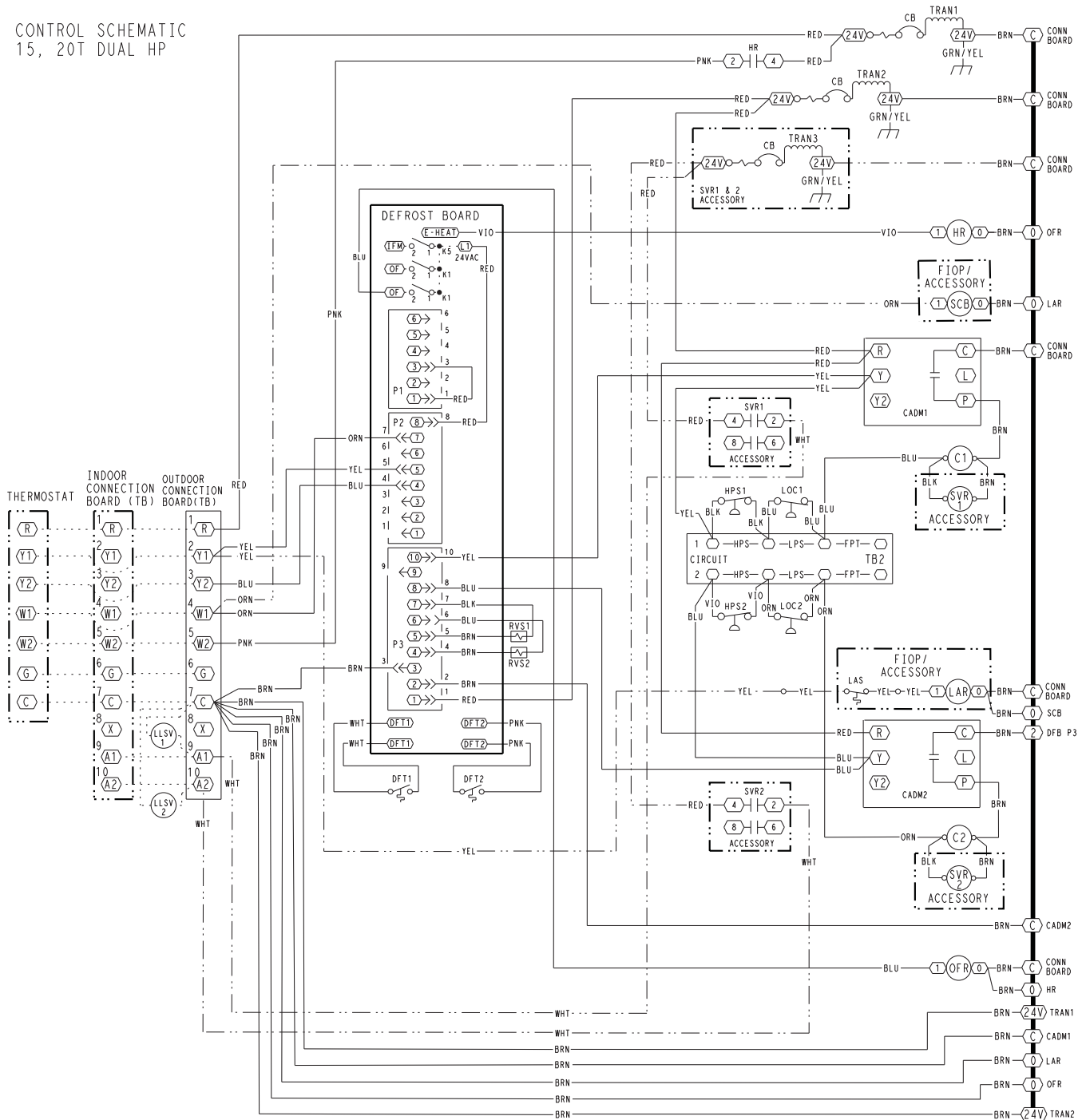

C10788

ELECTRICAL DATA

WITHOUT POWERED CONVENIENCE OUTLET - CHS072-121

UNIT CHS	NOMINAL POWER SUPPLY	VOLTAGE RANGE		COMPRESSOR		OFM		POWER SUPPLY		DISCONNECT SIZE	
	V-Ph-Hz	Min	Max	RLA	LRA	Qty	FLA (ea)	MCA	MOCP	FLA	LRA
072	208/230-3-60	187	253	19.0	123	2	1.5	26.8/26.8	45/45	25/25	129/129
	460-3-60	414	506	9.7	62	2	0.9	13.9	20	13	66
	575-3-60	518	633	7.4	50	2	0.6	10.5	15	10	54
091	208/230-3-60	187	253	25.0	164	2	1.5	34.3/34.3	50/50	32/32	170/170
	460-3-60	414	506	12.2	100	2	0.9	17.1	25	16	104
	575-3-60	518	633	9.0	78	2	0.6	12.5	20	12	82
121	208/230-3-60	187	253	30.1	225	2	1.5	40.6/40.6	60/60	38/38	231/231
	460-3-60	414	506	16.7	114	2	0.8	22.5	30	21	118
	575-3-60	518	633	12.2	80	2	0.6	16.5	25	15	84

WITHOUT POWERED CONVENIENCE OUTLET - CHS180-240

UNIT CHS	NOMINAL POWER SUPPLY	VOLTAGE RANGE		COMPRESSOR				OFM		POWER SUPPLY		DISCONNECT SIZE	
				No. 1		No. 2							
	V-Ph-Hz	Min	Max	RLA	LRA	RLA	LRA	Qty	FLA (ea)	MCA	MOCP	FLA	LRA
180	208/230-3-60	187	253	25.0	164	25.0	164	3	1.5	60.8/60.8	80/80	63/63	337/337
	460-3-60	414	506	12.2	100	12.2	100	3	0.8	29.9	40	31	206
	575-3-60	518	633	9.7	78	9.7	78	3	0.7	23.9	30	25	162
240	208/230-3-60	187	253	30.1	225	30.1	225	4	1.5	73.7/73.7	100/100	76/76	462/462
	460-3-60	414	506	16.7	114	16.7	114	4	0.8	40.8	50	42	236
	575-3-60	518	633	12.2	80	12.2	80	4	0.7	30.3	40	31	168

TYPICAL PIPING AND WIRING - HORIZONTAL INSTALLATION

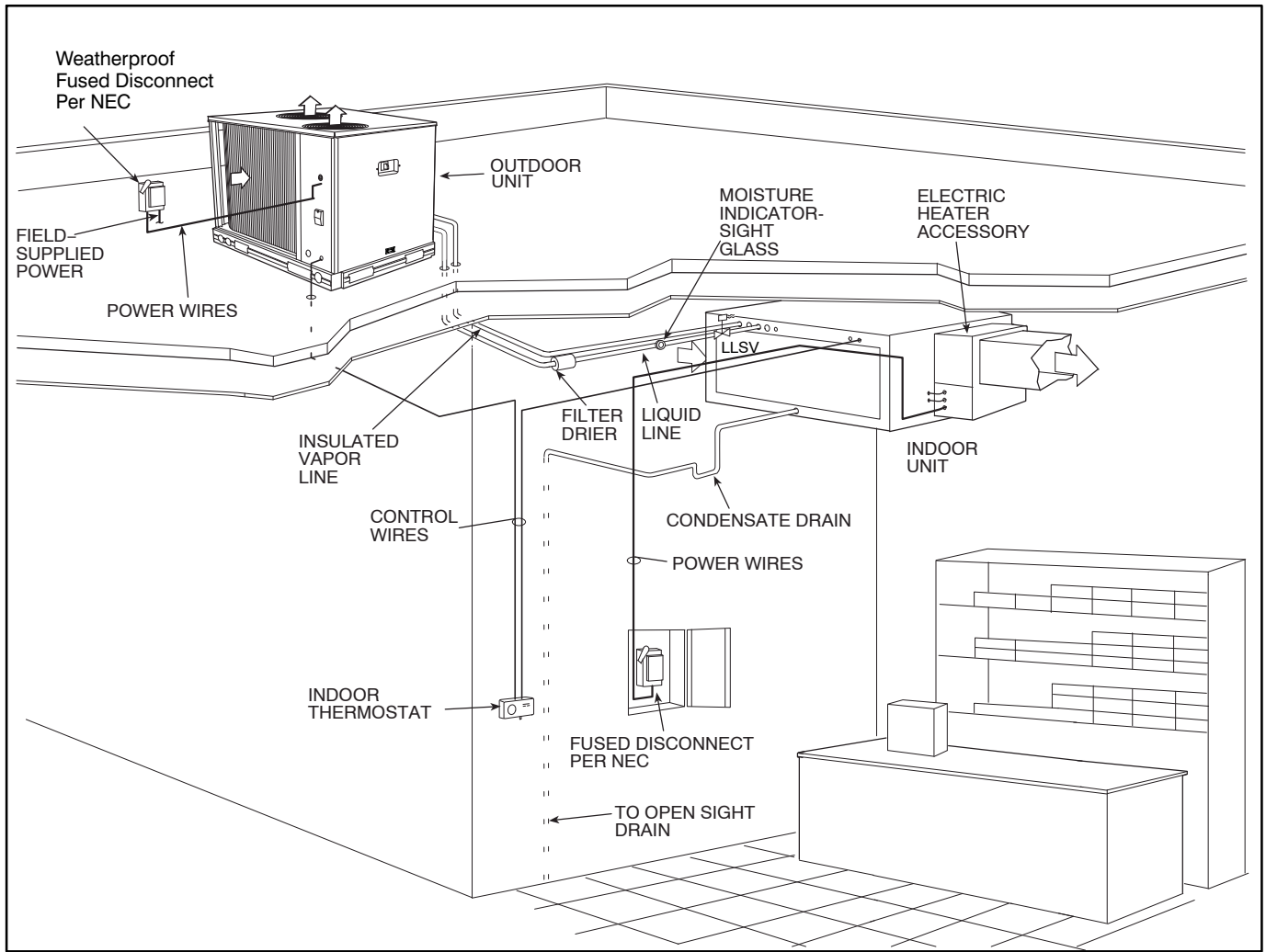

TYPICAL PIPING AND WIRING – ROOFTOP INSTALLATION (CONT.)

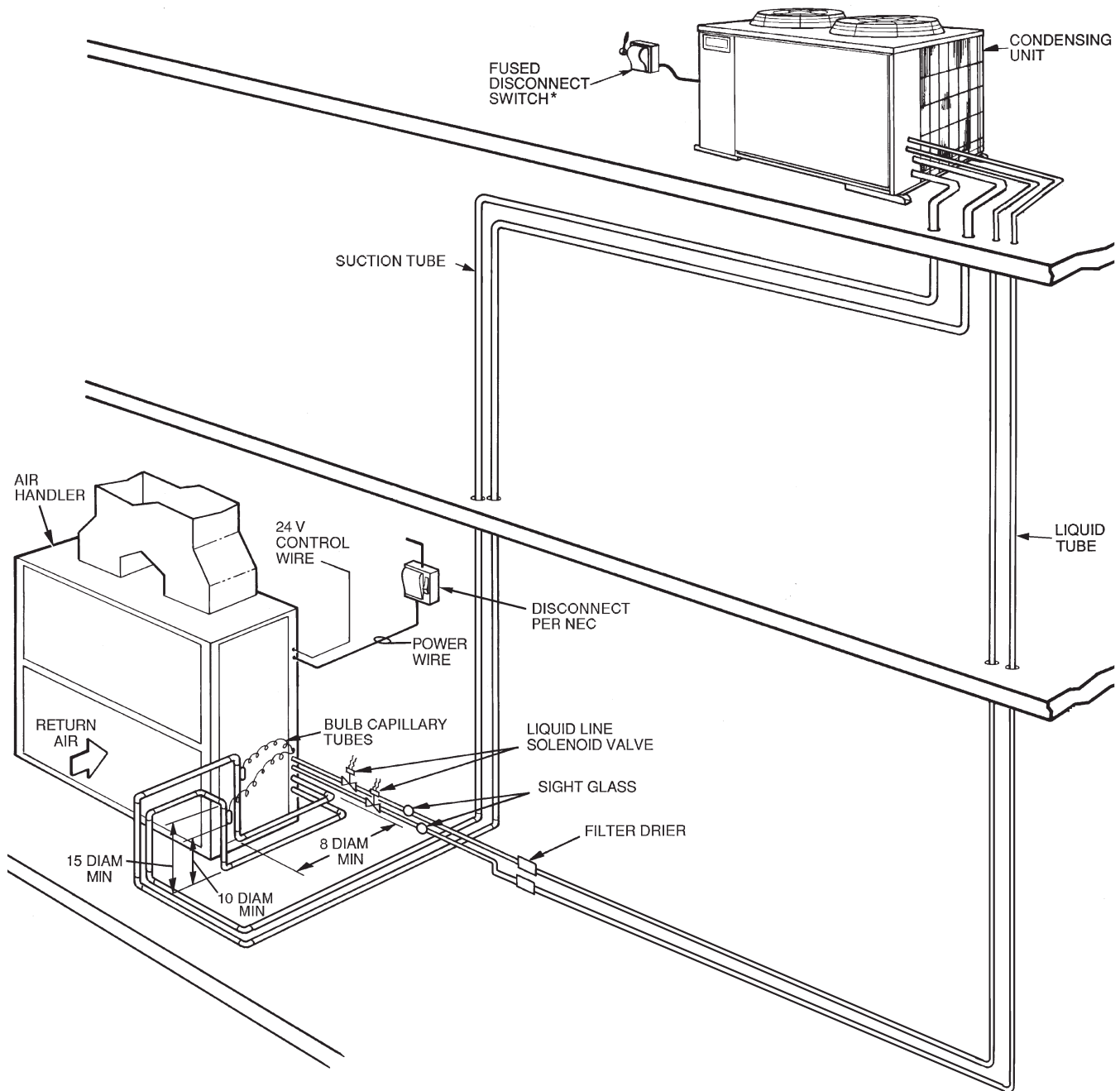

NOTES:

1. All piping must follow standard refrigerant piping techniques.
2. All wiring must comply with the applicable local and national codes.
3. Wiring and piping shown are general points-of-connection guides only and are not intended for, or to include all details for, a specific installation.
4. Liquid line solenoid valve (solenoid drop control) is recommended to prevent refrigerant migration to the compressor.
5. Internal factory-supplied TXVs not shown.

CHS072-121 Piping Recommendations (Single-Circuit Unit)

R-410A	Equivalent Length					
	Ft	0-38	38-75	75-113	113-150	
Model Nominal Capacity	Length Linear	0-25	25-50	50-75	75-100	
	Length Equiv	0-38	38-75	75-113	113-115	
CHS072	Liquid Line	3/8	3/8	3/8	1/2	3/8 1/2
	Max Lift					
	Cool	25	50	48	75	39 100
	Heat	25	50	46	60	31 60
	Suction Line	7/8	7/8	1-1/8	1-1/8	
	Charge (lbs)	17.8	18.8	20.3	22.6	21.4 24.5
CHS091	Liquid Line	1/2	1/2	1/2	1/2	
	Max Lift					
	Cool	25	50	75	100	
	Heat	25	50	60	60	
	Suction Line	7/8	1-1/8	1-1/8	1-1/8	1-1/8
	Charge (lbs)	20.9	23.0	24.9	26.8	
CHS121	Liquid Line	1/2	1/2	1/2	1/2 5/8	
	Max Lift					
	Cool	25	50	75	85 100	
	Heat	25	50	60	60 60	
	Suction Line	7/8	1-1/8	1-1/8	1-1/8	1-1/8 1-3/8
	Charge (lbs)	26.8	28.8	30.7	33.4 37.2	
Legend:						
Length Equiv	Equivalent tubing length, including effects of refrigeration specialties devices					
Liquid Line	Tubing size, inches OD.					
Max Lift Cooling Heating	Maximum liquid lift at maximum permitted liquid line pressure drop <ul style="list-style-type: none"> • Indoor unit ABOVE outdoor unit • Indoor unit BELOW outdoor unit 					
Suction Line	Tube size, inches OD					
Charge	Charge Quantity, lbs. Calculated for both liquid line sizes (where applicable), but only with large suction line size (where applicable)					
NOTE:	For applications with linear length greater than 100 ft (30.5 m), contact your local distributor.					

CHS180–240 Piping Recommendations (Two-Circuit Unit)

R-410A	Equivalent Length					
Model Nominal Capacity	Length Equiv	0-38	38-75	75-113	113-150	150-188
	Length Lin	0-25	25-50	50-75	75-100	100-125
CHS180	Liquid Line	1/2	1/2	1/2	1/2	1/2
	Max Lift					
	Cool	25	50	75	100	125
	Heat	25	50	60	60	60
	Vapor Line	1 1/8	1 1/8	1 1/8	1 1/8	1 1/8
Charge ea. (lbs)	20.9	22.8	24.8	26.6	28.6	
CHS240	Liquid Line	1/2	1/2 5/8	1/2 5/8	5/8	5/8
	Max Lift					
	Cool	25	37 50	24 51	48	63
	Heat	25	50 50	60 60	60	60
	Vapor Line	1 1/8	1 1/8	1 1/8	1 1/8 1 3/8	1 3/8
Charge ea. (lbs)	26.9	28.8 30.7	30.7 33.6	37.1	40.2	
Legend:						
Length Equiv	Equivalent tubing length, including effects of refrigeration specialties devices					
Linear Lin	Typical linear tubing length, Feet (50% added to linear to define Equivalent Length for this table)					
Liquid Line	Tubing size, inches OD.					
Max Lift	Maximum liquid lift (indoor unit ABOVE outdoor unit only), at maximum permitted liquid line pressure drop — <ul style="list-style-type: none"> • Linear Length Less than 100 ft: Minimum 2.0°F subcooling entering TXV • Linear Length Greater than 100 ft: Minimum 0.5°F subcooling entering TXV 					
Vapor Line	Tube size, inches OD					
Charge	Charge Quantity, lbs. Calculated for both liquid line sizes (where applicable), but only with larger suction line size (where applicable)					
NOTE:	For applications with equivalent length greater than 188 ft (57 m) and/or linear length greater than 125 ft (38 m), contact your local distributor.					

APPLICATION DATA

REFRIGERANT LINE SIZING — Consider the length of the piping required between the outdoor and indoor units. The maximum allowable line length is 100 ft (30.5 m). See Maximum Vertical Separation Table below. Refrigerant vapor piping should be insulated

IMPORTANT: A refrigerant receiver is not provided with the unit. Do not install a receiver.

INSTALL FILTER DRIER(S) AND MOISTURE INDICATOR(S) — Every unit **MUST** have a bi-directional filter drier in the liquid line. Locate the filter drier at the indoor unit, close to the evaporator coil thermal expansion valve (TXV) inlets.

CHS units include one R-410A-duty filter drier, shipped in cartons attached to the unit base pan. Remove the filter drier and prepare to install in the liquid line at the evaporator coil. Do not remove connection fitting plugs until ready to connect and braze the filter drier into the liquid line position.

Installation of liquid line moisture indicating sight glass in each circuit is recommended. Locate the sight glass(es) between the outlet of the filter drier and the TXV inlet.

Refer to Refrigerant Specialties Part Numbers Table for recommendations on refrigeration specialties.

Select the filter drier for maximum unit capacity and minimum pressure drop. Complete the refrigerant piping from the indoor unit to the outdoor unit before opening the liquid and suction lines at the outdoor unit.

INSTALL LIQUID LINE SOLENOID VALVE — It is recommended that a bi-directional solenoid valve be placed in the main liquid line (see Figs. 1 & 2) between the outdoor unit and the indoor coil. Locate the solenoid valve at the end of the liquid line, near the outdoor unit connections, with flow direction arrow pointed at the outdoor unit. Refer to Refrigerant Specialties Part Numbers Table below. (A liquid line solenoid valve is required when the liquid line length exceeds 75 ft [23 m].) This valve prevents refrigerant migration (which causes oil dilution) to the compressor

during the off cycle, at low outdoor ambient temperatures. Wire the solenoid according to the unit label

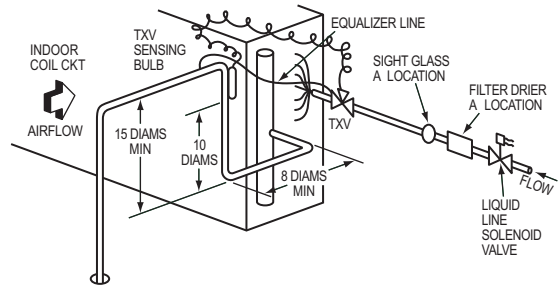

LEGEND

TXV — Thermostatic Expansion Valve

Fig. 1 – Location of Sight Glass(es) and Filter Driers (typical CHS/FHS 6 & 7.5 ton system)

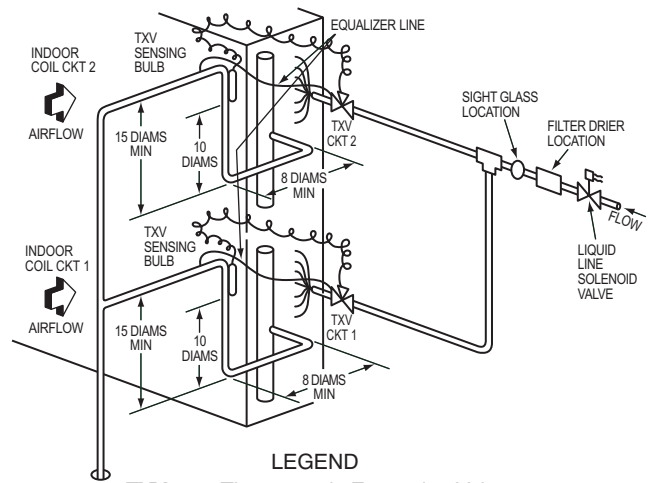

LEGEND

TXV — Thermostatic Expansion Valve

Fig. 2 – Location of Sight Glass(es) and Filter Driers (typical CHS/FHS 10 Ton system)

Refrigerant Specialties Part Numbers

LIQUID LINE SIZE (in.)	LIQUID LINE SOLENOID VALVE (LLSV)	LLSV COIL	SIGHT GLASS	FILTER DRIER
3/8	1179871 plus 1183150 bi-flow kit	1178273	1179879	Provided with unit.
1/2	1179872 plus 1183150 bi-flow kit	1178273	1179878	
5/8	1179873 plus 1183150 bi-flow kit	1178273	1179877	

GUIDE SPECIFICATIONS – CHS072–240

Split System Heat Pump Outdoor Unit with R–410A Refrigerant

HVAC Guide Specifications — Section 15678

Size Range: **66,000 to 214,000 Btuh Heating**
6 to 20 Nominal Tons Cooling

Part 1 — General

1.01 SYSTEM DESCRIPTION

- A. Outdoor–mounted, electrically controlled, air–cooled split system heat pump suitable for on–the–ground or rooftop installation. Unit shall consist of a scroll air–conditioning compressor assembly, an air–cooled coil, propeller–type condenser fans, and a control box. Unit shall discharge supply air upward as shown on contract drawings. Unit shall function as the outdoor component of an air to air electric heat pump system.
- B. Unit must be designed with a R–410A refrigerant circuit to match Packaged Heat Pump Air Handling Unit(s), FHS for matched systems approved by the manufacturer.

1.02 QUALITY ASSURANCE

- A. Unit shall be rated in accordance with ARI Standard 340/360.
- B. Unit construction shall comply with ANSI/ASHRAE 15 safety code latest revision and comply with NEC.
- C. Unit shall be constructed in accordance with UL 1995 standard and shall carry the UL and UL, Canada label.
- D. Unit cabinet shall be capable of withstanding 500–hour salt spray exposure per ASTM B117 (scribed specimen).
- E. Air–cooled outdoor coils shall be leak tested at 150 psig and pressure tested at 650 psig and qualified to UL burst test at 1980 psig.
- F. Unit shall be manufactured in a facility registered to ISO 9001:2000 manufacturing quality standard.

1.03 DELIVERY, STORAGE AND HANDLING

Unit shall be shipped as single package only, and shall be stored and handled according to unit manufacturer's recommendations.

1.04 WARRANTY (FOR INCLUSION BY SPECIFYING ENGINEER)

Part 2 — Products

2.01 EQUIPMENT

- A. General:
Factory–assembled, single piece, air–cooled split system heat pump. Contained within the unit enclosure shall be all factory wiring, piping, controls, compressor, holding charge R–410A, and special features required prior to field start–up.
- B. Unit Cabinet:
 - 1. Unit cabinet shall be constructed of galvanized steel, bonderized and coated with a pre–painted baked enamel finish.
 - 2. A heavy–gauge roll–formed perimeter base rail with forklift slots and lifting holes shall be provided to facilitate rigging.
- C. Fans:
 - 1. Condenser fans shall be direct driven, propeller type, discharging air vertically upward.
 - 2. Fan blades shall be balanced.
 - 3. Condenser fan discharge openings shall be equipped with PVC coated steel wire safety guards.
 - 4. Condenser fan and motor shaft shall be corrosion resistant.
- D. Compressor:
 - 1. Compressor shall be of the hermetic scroll type.
 - 2. Compressor shall be mounted on rubber grommets.
 - 3. Compressor shall include overload protection.
 - 4. Compressors shall be equipped with a crankcase heater.
 - 5. Compressor shall be equipped with internal high discharge temperature protection.
- E. Coil:
 - 1. Coil shall be air–cooled and circuited for sub cooling during cooling mode of operation.
 - 2. Coil shall be constructed of aluminum fins (copper fins optional) mechanically bonded to internally grooved seamless copper tubes which are then cleaned, dehydrated, and sealed.
- F. Refrigeration Components and Operation:
 - 1. Refrigeration circuit components shall include liquid line service valve, suction line service valve, a full charge of compressor oil, and a holding charge of refrigerant.
 - 2. Precision sized suction line accumulator on each refrigerant circuit shall protect from oil being removed from the scroll compressor rotating orbiter and plate during the activation of the defrost mode and switching back and forth from cooling and heating operations.

3. Unit shall be capable of starting and running up to 125° F (52° C) and down to 35° F (2° C) ambient outdoor temperature.
 4. Unit shall operate at +/- 10% from rated voltage
- G. Controls and Safeties:
1. Minimum control functions shall include:
 - a. Control wire terminal blocks.
 - b. Compressor lockout on auto–reset safety until reset from thermostat.
 - c. Each unit shall utilize the Comfort Alert™ Diagnostic Board that provides:
 - (1.) System Pressure Trip fault code indication
 - (2.) Short Cycling fault code indication
 - (3.) Locked Rotor fault code indication
 - (4.) Open Circuit fault code indication
 - (5.) Reverse Phase 3 fault code indication
 - (6.) Welded Contactor fault code indication
 - (7.) Low Voltage fault code indication
 - (8.) Anti–short cycle protection
 - (9.) Phase reversal protection
 2. Minimum safety devices which are equipped with automatic reset (after resetting first at thermostat), shall include:
 - a. High discharge pressure protection switch.
 - b. Loss–of–charge protection switch.
- H. Electrical Requirements:
1. Unit electrical power shall be single–point connection.
 2. Unit control circuit shall contain a 75VA – 24–v transformer for unit control.
- I. Special Features:
1. Unit–Mounted, Non–Fused Disconnect Switch:
Switch shall be factory–installed and internally mounted. NEC and UL–approved non–fused switch shall provide unit power shutoff. Switch shall be accessible from outside the unit and shall provide power off lockout capability.
 2. Convenience Outlet:
 - c. Non–Powered convenience outlet.
 - (1.) Outlet shall be powered from a separate 115/120v power source.
 - (2.) A transformer shall not be included.
 - (3.) Outlet shall be factory–installed and internally mounted with easily accessible 115–v female receptacle.
 - (4.) Outlet shall include 15 amp GFI receptacles with independent fuse protection.
 - (5.) Outlet shall be accessible from outside the unit.
 - (6.) Outlet shall include a field–installed “Wet in Use” cover.
 3. Low–Ambient Temperature Control:
A low–ambient temperature control shall be available as a factory–installed option or as a field–installed accessory. This low–ambient control shall regulate speed of the condenser–fan motors in response to the saturated condensing temperature of the unit. The control shall maintain correct condensing pressure at outdoor temperatures down to –20 F (–29 C).
 4. Optional Outdoor Coil Materials:
 - a. Pre–Coated Aluminum–Fin Coils:
Coils shall have a durable epoxy–phenolic coating to provide protection in mildly corrosive coastal environments. Coating shall be applied to the aluminum fin stock prior to the fin stamping process to create an inert barrier between the aluminum fin and copper tube. Epoxy–phenolic barrier shall minimize galvanic action between dissimilar metals.
 - b. E–Coated Aluminum–Fin Coils:
Coils shall have a flexible epoxy polymer coating uniformly applied to all coil surface areas without material bridging between fins. Coating process shall ensure complete coil encapsulation. Color shall be high gloss black with gloss requirements of 60° of 65 to 90% per ASTM D523–89. Uniform dry film thickness from 0.8 to 1.2 mil on all surface areas including fin edges. Superior hardness characteristics of 2H per ASTM D3363–92A and cross hatch adhesion of 4B–5B per ASTM D3359–93. Impact resistance shall be up to 160 in./lb (ASTM D2794–93). Humidity and water immersion resistance shall be up to a minimum of 1000 and 250 hours respectively (ASTM D2247–92 and ASTM D870–92). Corrosion durability shall be confirmed through testing to no less than 1000 hours salt spray per ASTM B117–90. Coil construction shall be aluminum fins mechanically bonded to copper tubes.
 5. Louvered hail guard Package:
Louvered hail guard package shall protect coils against damage from hail and other flying debris.
 6. Outdoor Coil Grille:
Grille shall add decorative appearance to unit and protect outdoor coil from large objects and vandalism.