



BSI: 069-276

Residential & Light Commercial
Gas-Fired Steam Boilers

BSI Series Submittal Sheet

Wholesaler _____
Job Name _____
Mechanical Contractor _____
Model Number _____ Quantity: _____
Gas Type _____
BTU/hr INPUT _____
BTU/hr OUTPUT _____
Venting Application _____

Standard Features

- ASME Cast Iron Heat Exchanger. Max. Allowable Working Pressure Steam - 15 psi.
- Seven Sizes Available: 069, 103, 138, 172, 207, 241, 276, MBH Input.
- United Technologies UT 1003-664A Ignition Module (Intermittent Ignition) Manages: Spark to Pilot, Flame Supervision.
- Redundant Gas Valve.
- BSI069 - BSI276 Available with Natural or LP Gas up to 2000 feet.
- Not for Installation at Altitudes Above 2000 ft.
- Stainless Steel Burners.
- Hydrolevel CG400 Probe LWCO.
- Designed for Installation on Combustible Floors.
- Built-in Draft Diverter to Fit Low Spaces.
- For Use with Conventional Category I Chimney.
- Includes Vent Damper, Flame Rollout Switch, Blocked Vent Switch, Pressure Gauge, Glass Water Level Gauge Set, Pressure Limit Switch & 15psi Relief Valve.
- Isolation Relay Simplifies Thermostat Wiring.
- Available Fully Assembled or as a Knock-Down Package (BSI241- BSI276 only).
- Residential 12 Year Limited Warranty On Cast Iron Heat Exchanger.
- Commercial 10 Year Limited Warranty On Cast Iron Heat Exchanger.
- 1 Year Warranty On Parts/Accessories Supplied by Velocity Boiler Works.
- A 5-Year and 10-Year Extended Warranty Covering Parts and Labor is Available. Visit velocityboilerworks.com for Complete Details.
- **Optional Accessories Include:** 67-M Manual Reset LWCO, L4079B Manual Reset Pressure Limit and VXT-24 Automatic Water Feeder.
- **Optional Near Boiler Piping Kits Available.** Visit velocityboilerworks.com for Complete Details.

Special Job Notes:

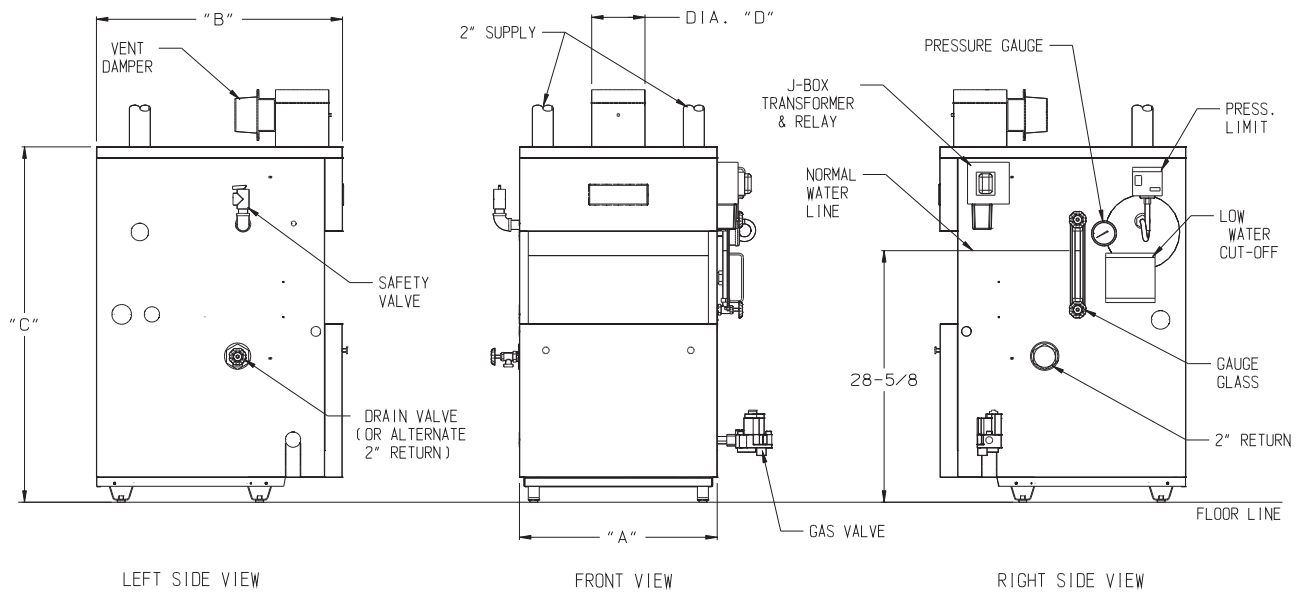

BSI SPACE HEATING RATINGS NATURAL AND LP GAS						NO. OF SEC.	DIMENSIONS (IN.)				SHIPPING WEIGHT (LBS)
CROWN MODEL NUMBER	INPUT (MBH)	HEATING CAPACITY (MBH)	AHRI NET RATING STEAM (MBH)		AFUE (%)		"A" (in)	"B" (in)	"C" (in)	"D" (in)	
			SQ. FT.	MBH							
BSI069	69	57	179	43	82.0	3	12-3/4	28	40-7/16	4	365
BSI103	103	85	267	64	82.0	4	16	28	40-7/16	5	432
BSI138	138	113	354	85	82.0	5	19-1/4	28	40-7/16	6	504
BSI172	172	142	446	107	82.1	6	22-1/2	28	40-7/16	6	589
BSI207	207	171	533	128	82.1	7	25-3/4	30	40-7/16	7	669
BSI241 [†]	241	199	621	149	82.2	8	29	30	40-7/16	7	745
BSI276 [†]	276	229	717	172	82.2	9	32-1/4	30	40-7/16	8	826

1. Not for use at altitudes above 2,000 ft. in natural or LP gas.
[†]Available as semi-packaged boiler.