

- AUXILIARY VIEW -  
FASTENING DIMENSIONS

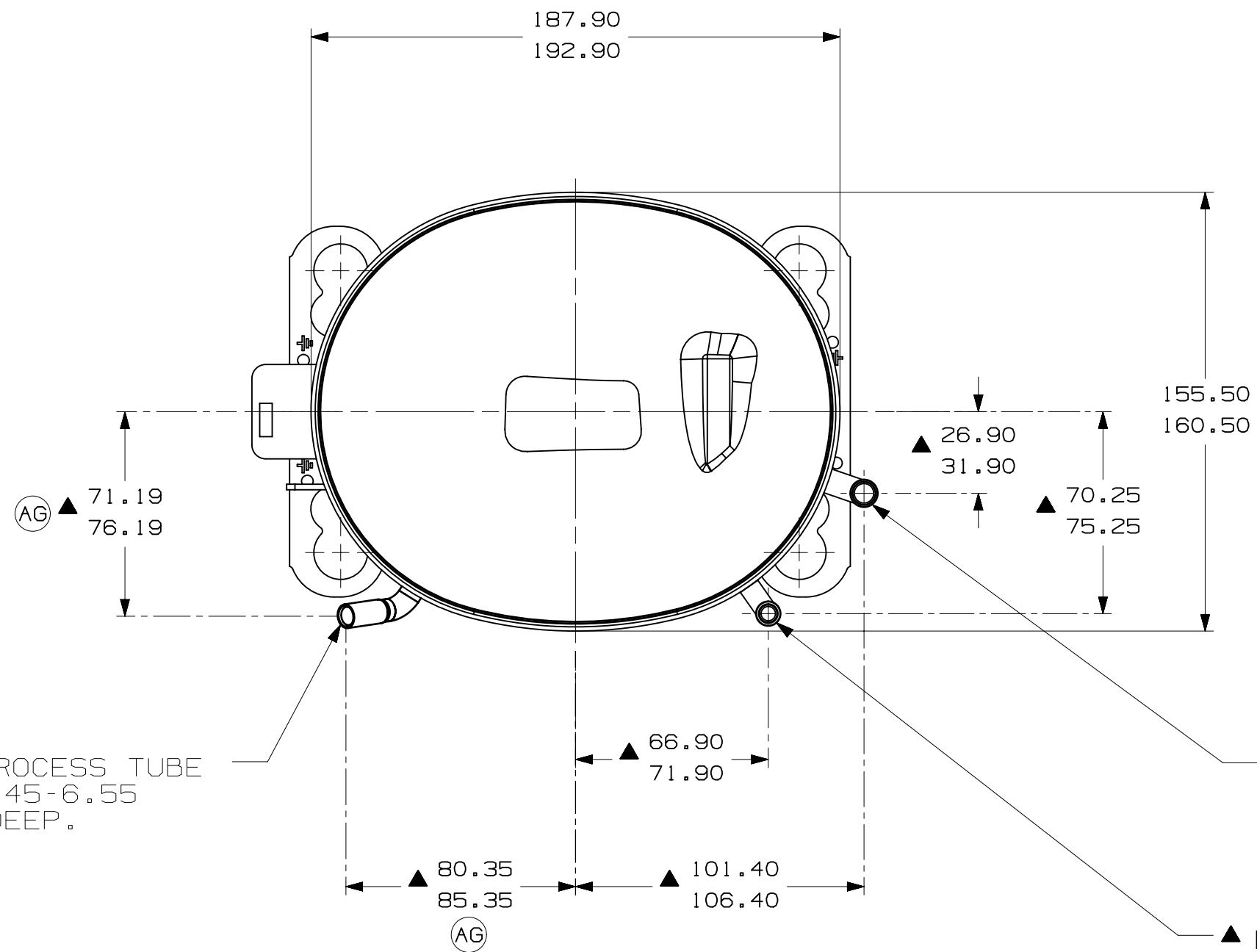

▲ C - (COPPER) PROCESS TUBE  
GAGE I.D. TO 6.45-6.55  
× 15.00-17.00 DEEP.

▲ E - (COPPER) SUCTION TUBE  
GAGE I.D. TO 8.00-8.10  
× 15.00-17.00 DEEP.

▲ D - (COPPER) DISCHARGE TUBE  
GAGE I.D. TO 6.45-6.55  
× 15.00-17.00 DEEP.

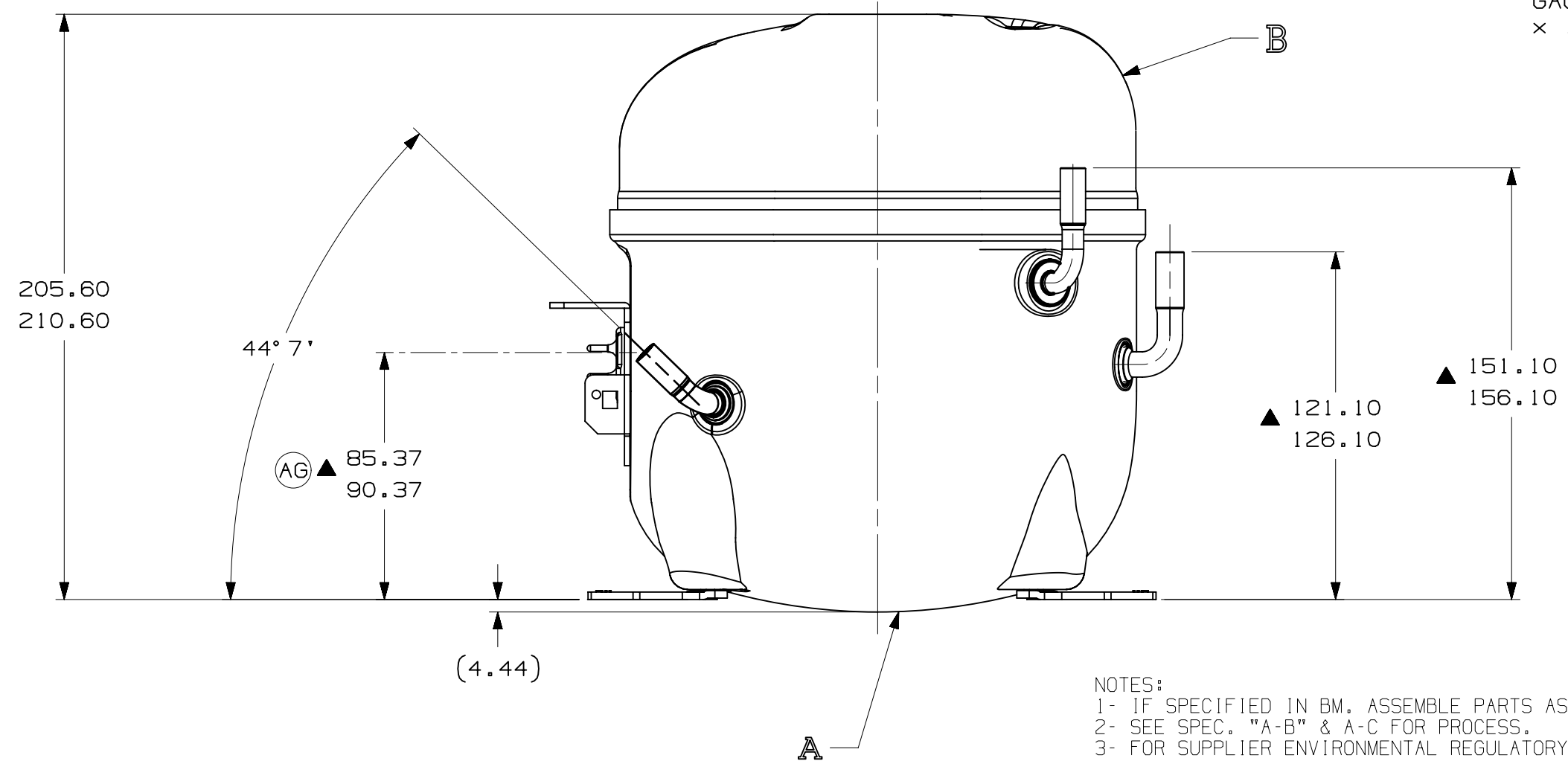
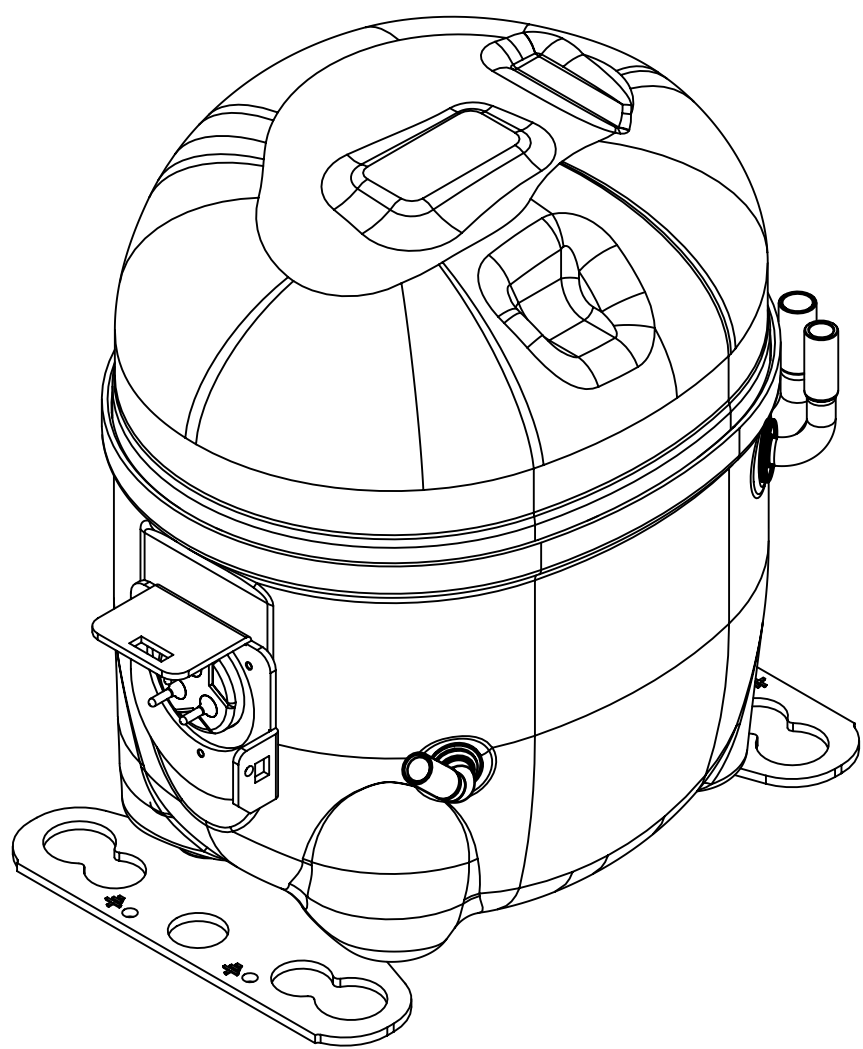

- NOTES:
- 1- IF SPECIFIED IN BM, ASSEMBLE PARTS AS SHOWN.
  - 2- SEE SPEC. "A-B" & A-C FOR PROCESS.
  - 3- FOR SUPPLIER ENVIRONMENTAL REGULATORY REQUIREMENTS, SEE TECUMSEH GLOBAL SPEC. 08
  - 4- THERE CAN BE NO CREASES IN THE TUBES. (CREASES ARE SIGNS OR MARKS THAT ARE IN SOMETHING THAT BENDS)
  - 5- AFTER THE FOLDS IN THE TUBES, CANNOT BE ACCELERATED TO AREA EXCEEDING 30%.
  - 6- TUBES OF SUCTION, DISCHARGE AND PROCESS MUST BE FREE OF INK ON 15.8mm (5/8") FROM TOP OF THE TUBES AS SPEC. T.P.Co. A-B4.

ITEM	PART NUMBER
A	320-10229
B	14963286
C	14947663
D	580-10243
E	14963571

EC102397 03-06-12 GM. R6.	EC80775 14-02-18 PS. R6.	EC70368 08-06-16 MP. R6.	EC59687 03-03-15 PS. R6.	EC48188 01-01-14 R6.	EC52840 AMP. R6. 13-09-13	EC45076 15/05/12 P.S. A.M.	DATE	THIRD ANGLE PROJECTION		<h1>Tecumseh</h1>	
B5 ERA 91.60-96.60	D4 ERA 86.60-91.60	E5 ERA 72.10-77.10	B1 ERA 14963573	F7/7 ALTERADA MEDIDA (AREA ISENTA DE PINTURA) ERA: 82.30-82.80	RETIRADO DETALHE (AREA ISENTA DE PINTURA)	ALTERADO TUBO D ERA: 14963518	ALTERADA MEDIDA ERA: 80.30-80.80	ADICIONADO NOTA			LIBERACAO
AG	AF	AE	AD	AC	AB	AA	LT	LC	CHANGE	UNITS: mm DRAWING SIZE: A2 O. A. SYMBOLS AS PROCEDURE 2.01.031 TECUMSEH OF BRAZIL * = CATEGORY I ▲ = CATEGORY II ■ = CATEGORY III ● = CATEGORY IV	NAME: SALES COMPRESSOR PART NO.: DCAE679 SCALE: 1:2 PAGE: 1/1 DATE: 19/04/12 REF.: FAMILY: AE2