

# SEP4™ combination hydraulic, air, dirt and magnetic separator



## 549, NA549\_M series



01249/19 NA  
Replaces 01249/17 NA

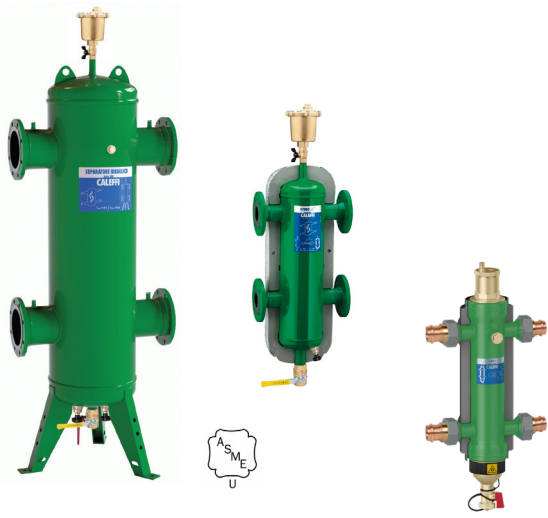

### Function

The Caleffi SEP4™ 4-in-1 combination separator incorporates four important functions for hydronic systems: hydraulic separation, air separation, dirt separation and ferrous impurity separation.

The unique geometry and design of the separator causes the connected primary and secondary circuits to be hydraulically de-coupled to prevent pump conflict from occurring. An internal screen element facilitates the coalescing and capture of micro-bubbles to facilitate high performance automatic removal, while concurrently causing the capture of non-ferrous debris particles down to 5 micron size. A powerful magnetic field induced by rare-earth neodymium magnets facilitates the capture of ferrous impurities such as iron oxide down to microscopic size thus delivering 2½ times the ferrous impurity removal performance of standard air and dirt separators.

The SEP4™ saves on system installation and maintenance costs as four devices are combined into one. Additionally, all captured debris is blown down through the purge valve without requiring to take the system offline.

### Product range

- 5495 series SEP4™ hydraulic, air, dirt and magnetic separator in steel with union connections, drain valve and insulation.....connections 1" to 2" sweat union, NPT female union and press union
  - 5495 series SEP4™ hydraulic, air, dirt and magnetic separator in steel with flanged connections, drain valve and insulation.....connections 2" to 4" ANSI
  - NA549\_M series SEP4™ hydraulic, air, dirt and magnetic separator in steel with flanged connections and drain valve, ASME.....connections 2" to 14" ANSI
- pre-formed insulation shell included on 2" – 4" sizes.  
-CRN approval for 2" – 10" sizes; consult factory for 12-14" sizes.

### Technical specifications

#### Threaded, sweat and press union connections

- Materials**
- body: epoxy resin coated steel
  - air vent body: brass EN 12165 CW617N
  - air vent hydraulic seal: EPDM
  - air vent float: PP
  - air vent float linkages: stainless steel
  - air vent float guide pin: stainless steel
  - internal element: HDPE
  - drain valve body: brass EN 12165 CW617N
  - magnet: neodymium rare-earth
  - insulation: closed-cell expanded PE-X

#### Performance

- Suitable fluids: water, glycol solution
- Max. percentage of glycol: 50%
- Max. working pressure: 150 psi (10 bar)
- Temperature range: without insulation 32–230°F (0–110°C)  
with insulation 32–210°F (0–100°C)
- Particle separation capacity: to 5 µm (0.2 mil)
- Air separation efficiency: 100% removal to microbubble level
- Ferrous impurities separation efficiency: up to 100% removal

#### Connections

- Main connections: 1", 1-¼", 1-½", 2" NPT female with unions  
1", 1-¼", 1-½", 2" sweat with unions  
1", 1-¼", 1-½", 2" press with unions
- Thermowell tap connection: ½" female straight thread
- Lay length (press connection): size 1 inch: 8-¾"  
size 1-¼ inch: 9-¾"  
size 1-½ inch: 11-5/8"  
size 2 inch: 12-½"
- Drain valve: ¾" garden hose connection

#### Technical specifications of insulation

See page 4.

### Dimensions

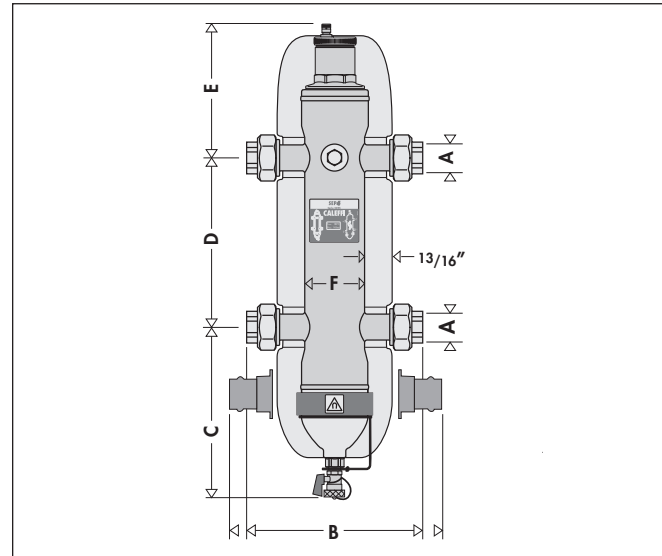

Code*	A	B swt	B npt	C	D	E	F	Wt. (lbs.)	Wt. (kg)
549506A/96A	1"	8¾"	8½"	7"	8½"	6"	3"	15	6.8
549507A/97A	1¼"	9¾"	9"	7"	9½"	6"	3½"	19	8.6
549508A/98A	1½"	11"	10½"	8½"	10¼"	7½"	4½"	27	12.2
549509A/99A	2"	12¾"	11½"	8½"	11½"	7½"	5¾"	29	13.1
549566A	1"	10½"	--	7"	8½"	6"	3"	15	6.8
549567A	1¼"	11¾"	--	7"	9½"	6"	3½"	19	8.6
549568A	1½"	14¼"	--	8½"	10¼"	7½"	4½"	27	12.2
549569A	2"	15½"	--	8½"	11½"	7½"	5¾"	29	13.1

\*54950: NPT female union connections; 54959: sweat union connections; 54956: press union connections.

## Technical specifications

### Flanged connections

<b>Materials</b>	- separator body:	epoxy resin painted steel
	- air vent body:	brass
	- shut off and drain valve body:	brass
	- internal element:	300 series stainless steel
	- air vent seal:	VITON
	- air vent float:	stainless steel
	- magnet:	neodymium rare-earth
	- magnet probe:	brass

### Performance

Suitable fluids:	water and non-hazardous glycol solution up to 50%
Max. operating pressure:	150 psi (10 bar)
Max. connection velocity:	4 feet per second (1.2 m/s)
Temperature range:	-with insulation: 32–220°F (0–105°C)
	-without insulation (vessel) 32–270°F (0–132°C)
Particle separation capacity:	5 µm (0.2 mil)
Air separation efficiency:	100% removal to micro-bubble level
Ferrous impurities separation efficiency:	up to 100% removal

<b>Connections</b>	- main:	2" – 14" ANSI B16.5 150 CLASS RF
	- drain valve:	2 – 4": 1" NPT female
		5 – 6": 1¼" NPT female
		8 – 14": 2" NPT female
	- thermo well tap (8 – 14" only):	
	- front center:	¾" NPT female
	- inlet/outlet flanges:	½" NPT female

### Dimensions

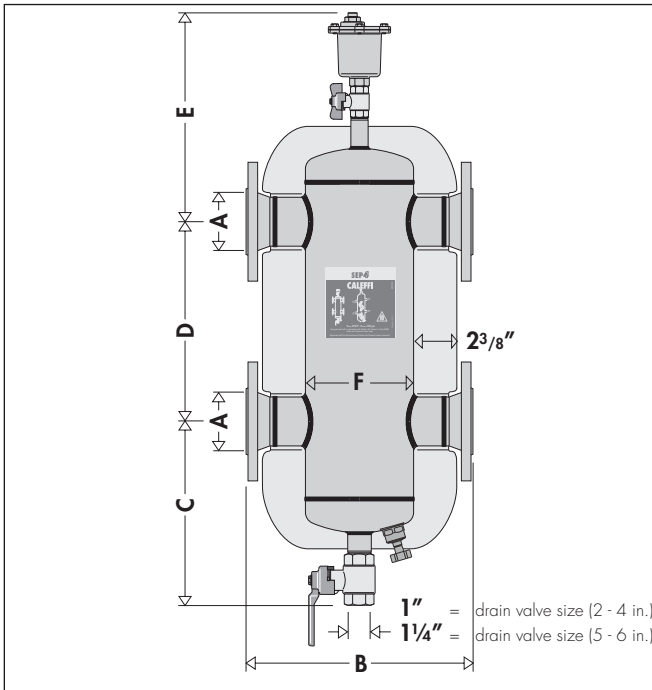

Code	A	B	C	D	E	F	Wt. (lbs.)	Wt. (kg)
549552A	2"	13½"	13"	13"	13½"	6"	76	35
549562A	2½"	13¾"	13"	13"	13½"	6"	82	37
549582A	3"	18½"	15"	17¾"	15½"	8"	112	50
549510A	4"	18½"	15"	17¾"	15½"	8"	120	55
NA549052AM	2"	13¾"	13"	13"	13½"	6"	76	35
NA549062AM	2½"	13¾"	13"	13"	13½"	6"	82	37
NA549082AM	3"	18½"	15"	17¾"	15½"	8"	112	50
NA549102AM	4"	18½"	15"	17¾"	15½"	8"	120	55
NA548120AM*	5"	25"	23⅞"	22"	18⅞"	12¾"	220	100
NA548150AM*	6"	25"	23⅞"	22"	18⅞"	12¾"	235	106

\*Without insulation.

2" to 6" NA549\_M are ASME tagged and registered with the National Board of Boiler and Pressure Vessel Inspectors and CRN registered, with ASME U stamp.

### Agency approval

Series NA549\_M is designed and built in accordance with Section VIII, Division 1 of the ASME Boiler and Pressure Vessel Code and tagged and registered with the National Board of Boiler and Pressure Vessel Inspector, and CRN registered, and stamped for 150 psi (10 bar) working pressure, with ASME U stamp. 12"-14" is CRN pending, contact Caleffi.

### Technical specifications of insulation, Flanged versions to 4"

#### Internal part

Materials:	rigid closed cell expanded polyurethane foam
Thickness:	2 3/8" (60 mm)
Density:	2.8 lb/ft <sup>3</sup> (45 kg/m <sup>3</sup> )
Thermal conductivity:	6 BTU·in/hr·ft <sup>2</sup> ·°F (0.023 W/(m·K))
Temperature range:	32–220°F (0–105°C)

#### Outer part

Materials:	embossed aluminum
Thickness:	7.0-mil (0.7 mm)
Reaction to fire (DIN 4102):	class 1

#### Head covers

Heat formed materials:	PS
------------------------	----

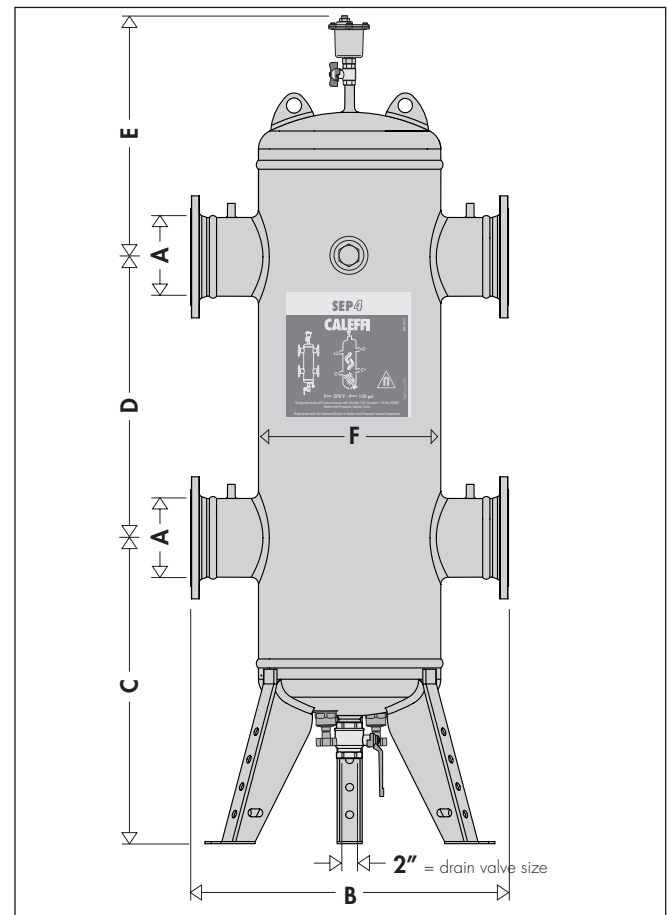

Code	A	B	C	D	E	F	Wt. (lbs.)	Wt. (kg)
NA549200AM	8"	35½"	36"	39½"	25½"	20"	530	236
NA549250AM	10"	41¼"	38½"	43⅞"	27⅞"	26"	740	331
NA549300AM	12"	46½"	37½"	47¼"	29⅞"	30"	1,110	500
NA549350AM	14"	52"	38⅞"	58⅞"	34½"	36"	1,550	703

8" to 14" NA549\_M are ASME tagged and registered with the National Board of Boiler and Pressure Vessel Inspectors and CRN (8" & 10" only), with ASME U stamp. Insulation is not included. Contact Caleffi for 12" & 14" CRN status.

## Operating principle

### Hydraulic separation

When a single system contains a primary production circuit, with its own pump, and a secondary user circuit, with one or more distribution pumps, operating conditions may arise in the system whereby the pumps interact, creating abnormal variations in circuit flow rates and pressures. The hydraulic separator creates a flow path with a low pressure loss, which enables the primary and secondary circuits connected to it to be hydraulically independent of each other; **the flow in one circuit does not affect flow in the other.**

In this case, the flow rate in the respective circuits depends exclusively on the flow rate characteristics of the circuit pumps, preventing reciprocal influence caused by connection in series. Therefore, using a device with these characteristics means that the flow in the secondary circuit only circulates when the relevant pump is on, permitting the system to meet the specific load requirements at that time.

When the secondary pump is off, there is no circulation in the secondary circuit; the whole flow rate produced by the primary pump is by-passed through the separator. With the hydraulic separator, it is therefore possible to have a primary production circuit with a constant flow rate and a secondary distribution circuit with a variable flow rate; these operating conditions are typical of modern heating and cooling systems.

Three possible hydraulic balance situations are shown below.

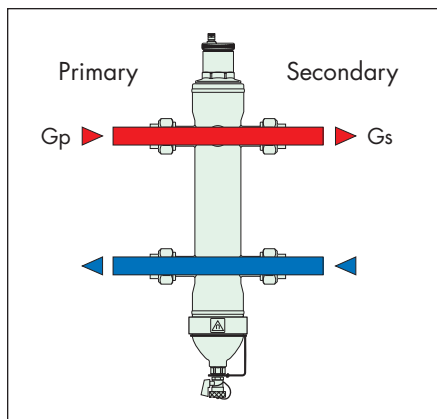
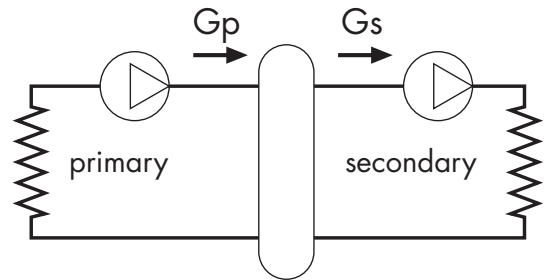

$G_{\text{primary}} = G_{\text{secondary}}$

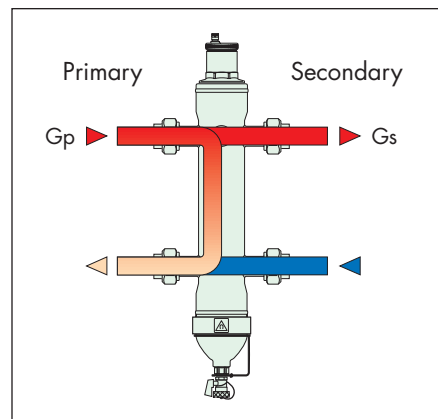

$G_{\text{primary}} > G_{\text{secondary}}$

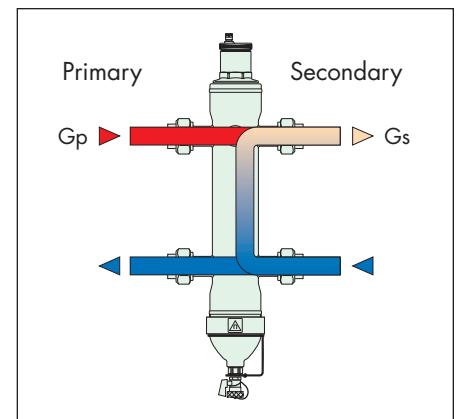

$G_{\text{primary}} < G_{\text{secondary}}$

**Microbubble air separation**

The SEP4's internal air separation element (1) creates the whirling movement required to facilitate the release of microbubbles and their adhesion to the internal element surfaces. The bubbles, fusing with each other, increase in size until the hydrostatic thrust overcomes the adhesion force to the mesh. They rise towards the top of the unit from which they are released through a float-operated automatic air vent.

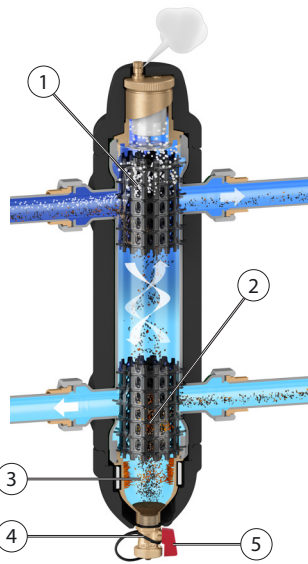

**Microparticle dirt separation**

Impurities in the fluid upon striking the surfaces of the SEP4's internal dirt separation element (2), get separated and drop to the bottom of the body (3) where they collect.

In addition, the large internal volume of SEP4™ slows down the flow speed of the fluid thus helping, by gravity, to separate the particles it contains.

The collected impurities are discharged, by opening the drain valve (4) with the handle (5), even with the system operating.

**Ferrous impurities separation**

The SEP4™ incorporates a fourth separation function by removing both non-ferrous and ferrous impurities, including magnetite, continuously. The SEP4™ features a powerful removable rare-earth magnet assembly below the flow line for fast and effective capture of ferrous particles. The SEP4™ ferrous impurities separation function causes no added system pressure drop since the magnet is positioned outside the flow path. Ferrous impurities, including magnetite, form in hydronics systems when iron or steel corrodes. Highly abrasive, the extremely fine particles are difficult to remove and can deposit onto heat exchange surfaces and accumulate in pump cavities causing reduced efficiency and premature wear. The SEP4™ accomplishes 2½ times the ferrous impurities removal performance of standard air and dirt separators, delivering up to 100% elimination efficiency.

SEP4 sizes 8" - 14" feature three removable magnet probes (A), sizes 2" - 6" feature one (B).

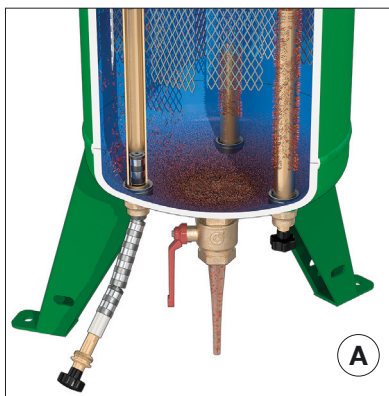

**4-in-1 high performance functionality**

Hydraulic separation

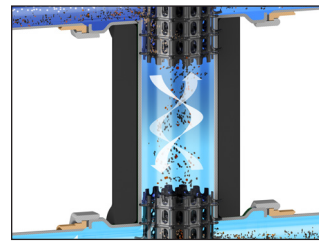

Air separation

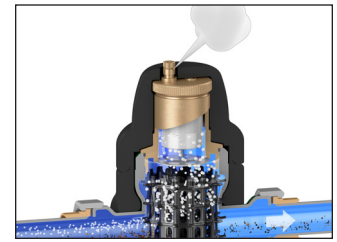

Dirt separation

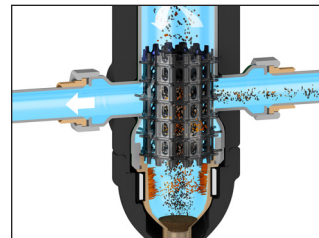

Magnetic removal of ferrous particles

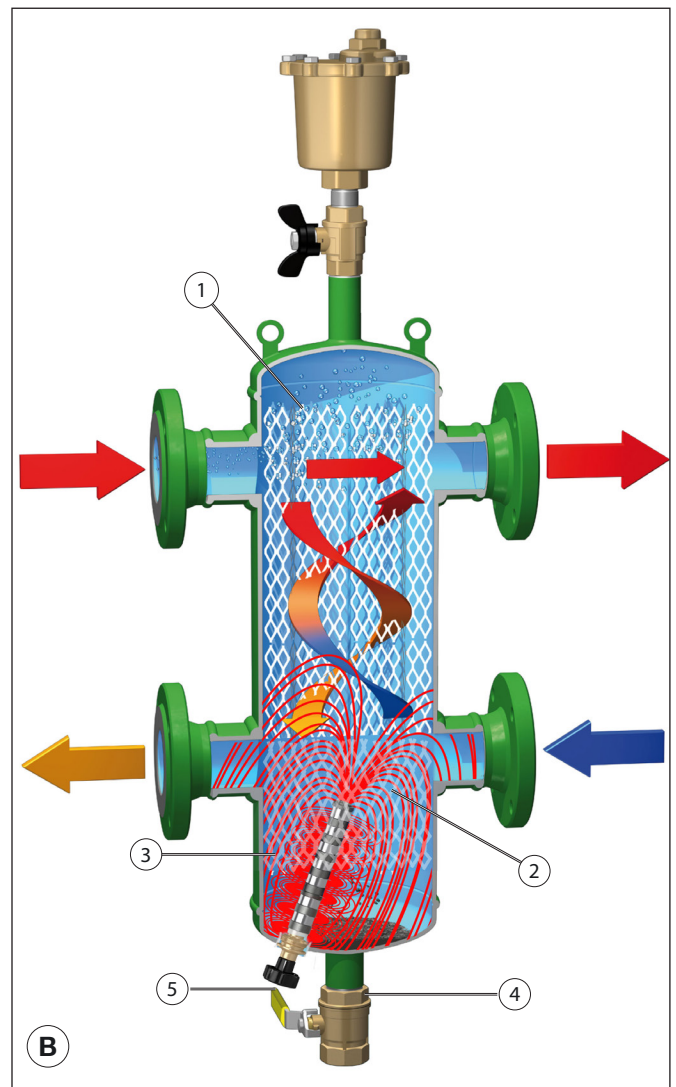
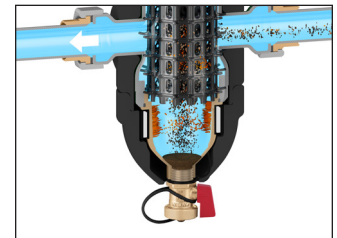

## Construction details

### Union connection models

The automatic air vent (A), located at the top of the units, has a long chamber for the movement of the float. This feature prevents any debris present in the water from reaching the sealing seat. A stainless steel float guide pin prevents the float from sticking due to accumulating residue in the flowing fluids, even when the SEP4™ is not installed perfectly vertical.

A replacement air vent assembly is code 59829.

The moving parts that control air venting are accessed simply by removing the upper cover. Replacement cap and float assembly for the union connection SEP4™ models is code F39807.

When cleaning, simply unscrew the portion of the body containing the automatic air vent.

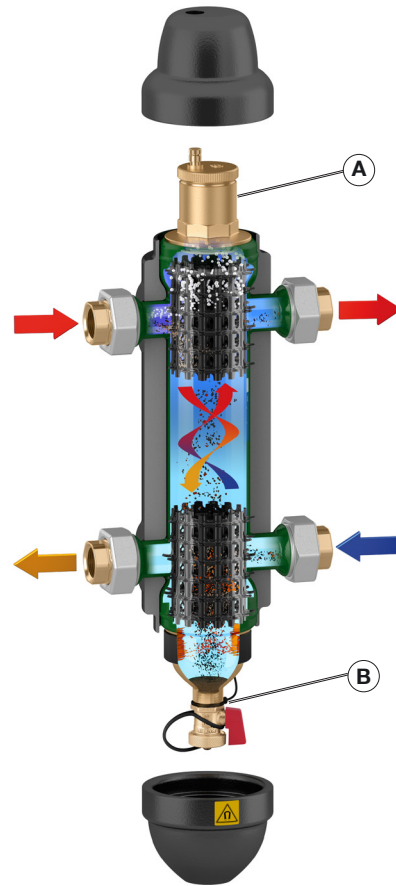

### Dirt removing element

The SEP4™ dirt removing element separates and collects any impurities present in the system.

These impurities are removed by the drain valve (B), which can be connected to a discharge hose (3/4" standard garden hose thread), at the bottom of the separator.

### Ferrous impurities removal element

The SEP4™ ferrous impurities removing element, a magnetic belt around the lower body, attracts and holds the magnetite in the lower body. These impurities are flushed by unclamping the collar and purging through the open drain valve- with the system operating.

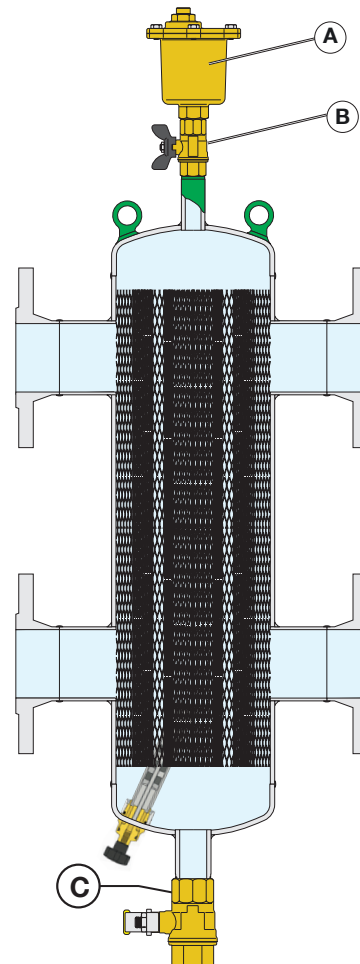
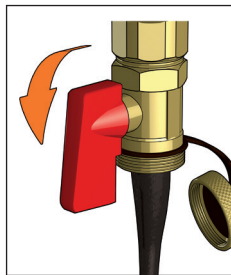
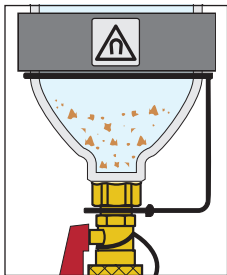

### Flange connection models

#### Isolating the air vent valve

The air vent (A), replacement part number 501502A, is isolated manually, using a shut-off ball valve (B), replacement part number NA39589.

#### Dirt removing element

The SEP4™ dirt removing element separates and collects any impurities present in the system.

These impurities are removed by the drain valve (C) replacement part number NA39753 for connection sizes 2–4"; NA39588 for connection sizes 5–6"; NA59600 for connection size 8–14", which can be connected to a discharge pipe, at the bottom of the separator.

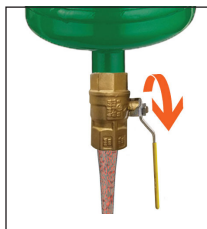

#### Ferrous impurities removal element

The SEP4™ ferrous impurities removing element is a flexible magnetic stack inside a brass dry-well probe (three for the 8 to 14 inch size SEP4™) just below the flow stream in the lower body. The probe(s) attracts and holds the magnetite in the lower body and is flushed by unscrewing the magnetic probe(s) and slowly pulling it out of the dry-well and purging through the open drain valve- aided by the system pressure.

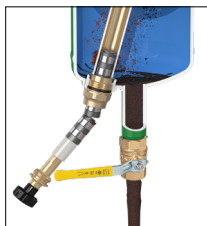

## Insulation

The SEP4™ comes standard with a preformed insulation shell for 1" to 2" union connections and 2" to 4" flanged connections. The insulation is made of a shell in closed-cell expanded PE-X foam. This insulation ensures not only perfect heat insulation but also the tightness required to prevent atmospheric water vapors from entering the unit. For these reasons, this type of insulation can also be used in cooling water circuits, as it prevents the formation of condensate on the surface of the separator body.

Note: Insulation shells are not available for sizes 5" through 14".

### Technical specifications of insulation for union connections

Material:	closed-cell expanded PE-X
Thickness:	13/16" (20 mm)
Density: - inner part:	1.9 lb/ft <sup>3</sup> (30 kg/m <sup>3</sup> )
- outer part:	5.0 lb/ft <sup>3</sup> (80 kg/m <sup>3</sup> )
Conductivity (ISO 2581):	at 32°F (0°C); .16 BTU/in (0.038 W/(m·K)) at 105°F (40°C); .26 BTU/in (0.045 W/(m·K))
Water vapor resistance coefficient (DIN 52615):	> 1,300
Temperature range:	32–212°F (0–100°C)
Fire resistance (DIN 4102):	class B2

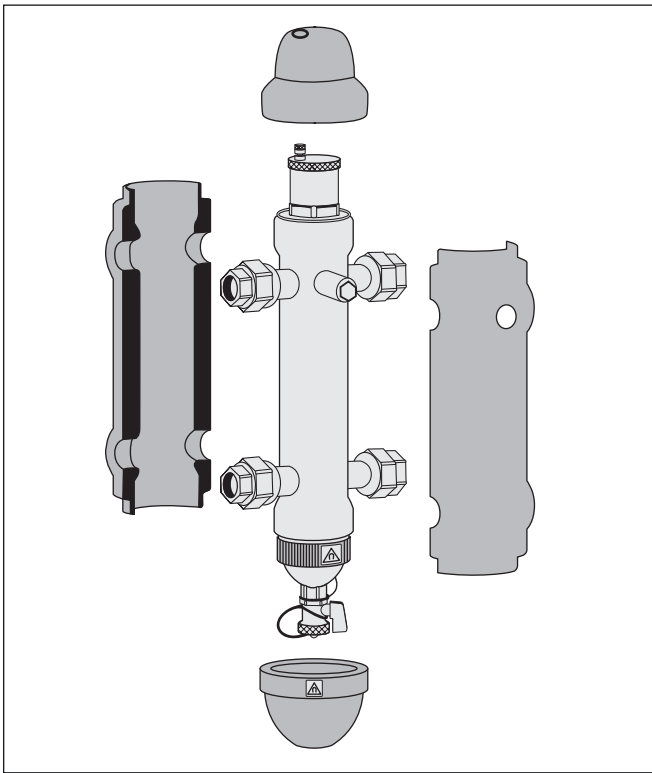

### Technical specifications of insulation, flanged versions to 4"

#### Internal part

Materials:	rigid closed cell expanded polyurethane foam
Thickness:	2 3/8" (60 mm)
Density:	2.8 lb/ft <sup>3</sup> (45 kg/m <sup>3</sup> )
Thermal conductivity:	6 BTU-in/hr-ft <sup>2</sup> -°F (0.023 W/(m·K))
Temperature range:	32–220°F (0–105°C)

#### Outer part

Materials:	embossed aluminum
Thickness:	7.0-mil (0.7 mm)
Reaction to fire (DIN 4102):	class 1

#### Head covers

Heat formed materials:	PS
------------------------	----

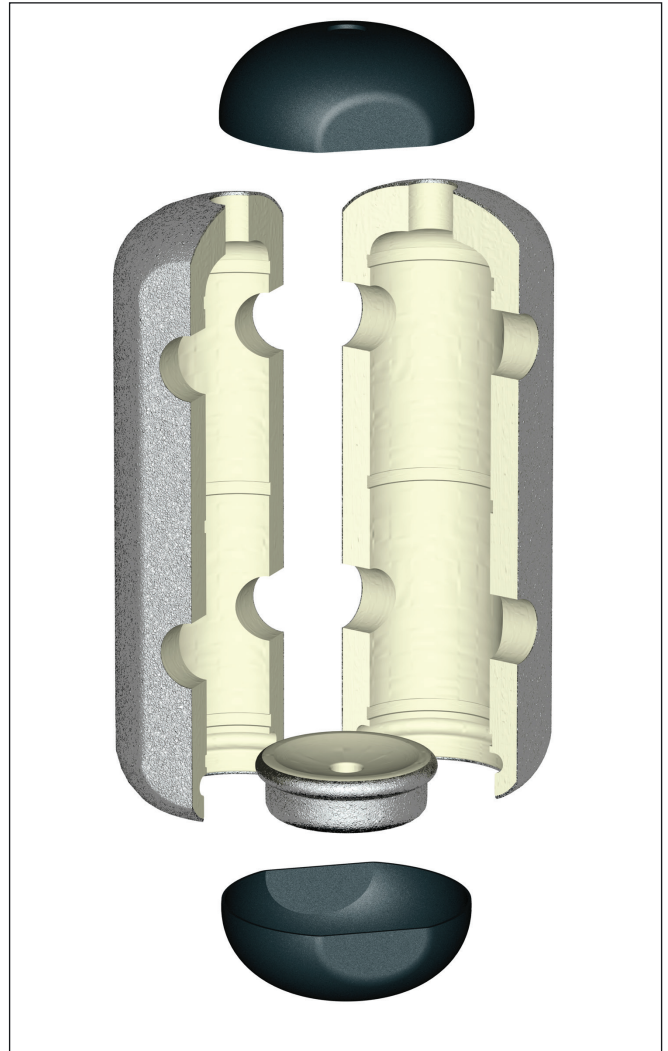

## Hydraulic characteristics

The SEP4™ should be sized according to the maximum flow rate of either the primary circuit, or secondary circuit, whichever is largest.

Size	1"	1¼"	1½"	2"	2"	2½"	3"	4"	5"	6"	8"	10"	12"	14"
gpm	11	18	26	37	60	80	124	247	300	484	792	1330	1850	2500
m <sup>3</sup> /h	2.5	4.0	6.0	8.5	13.6	18.2	28.2	56	68	110	180	302	420	568
l/s	0.7	1.1	1.6	2.3	3.8	5.0	7.8	15.6	19	30.5	50	84	117	158
Gallons	0.5	0.7	1.3	3.5	4.0	4.0	8.0	8.0	23	23	95	175	255	450
liters	2.0	2.6	5.0	13.2	15.1	15.1	30	30	87	87	360	662	965	1703

## Maintenance

### Union connection models

#### Dirt separation element

To perform maintenance simply use a 26 mm hexagon wrench to unscrew the dirt collection chamber, to which the inner dirt separation element mesh element is connected, for removal and for cleaning.

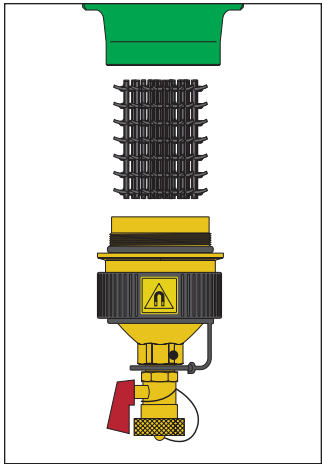

#### Air separation element

The automatic air release valve, located on the top of the unit, has a long chamber for the movement of the float. This feature prevents any debris present in the water from reaching the sealing seat.

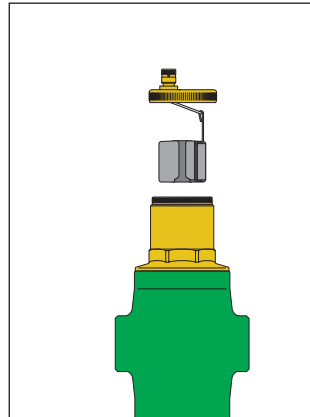

The moving parts that control the air venting are accessed simply by removing the upper cover.

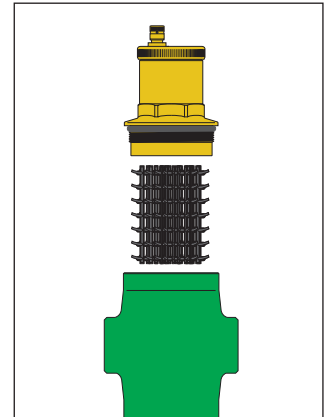

When cleaning, simply unscrew the portion of the body containing the automatic air vent valve. The inner air separation mesh element can be removed for cleaning.

## Application diagram

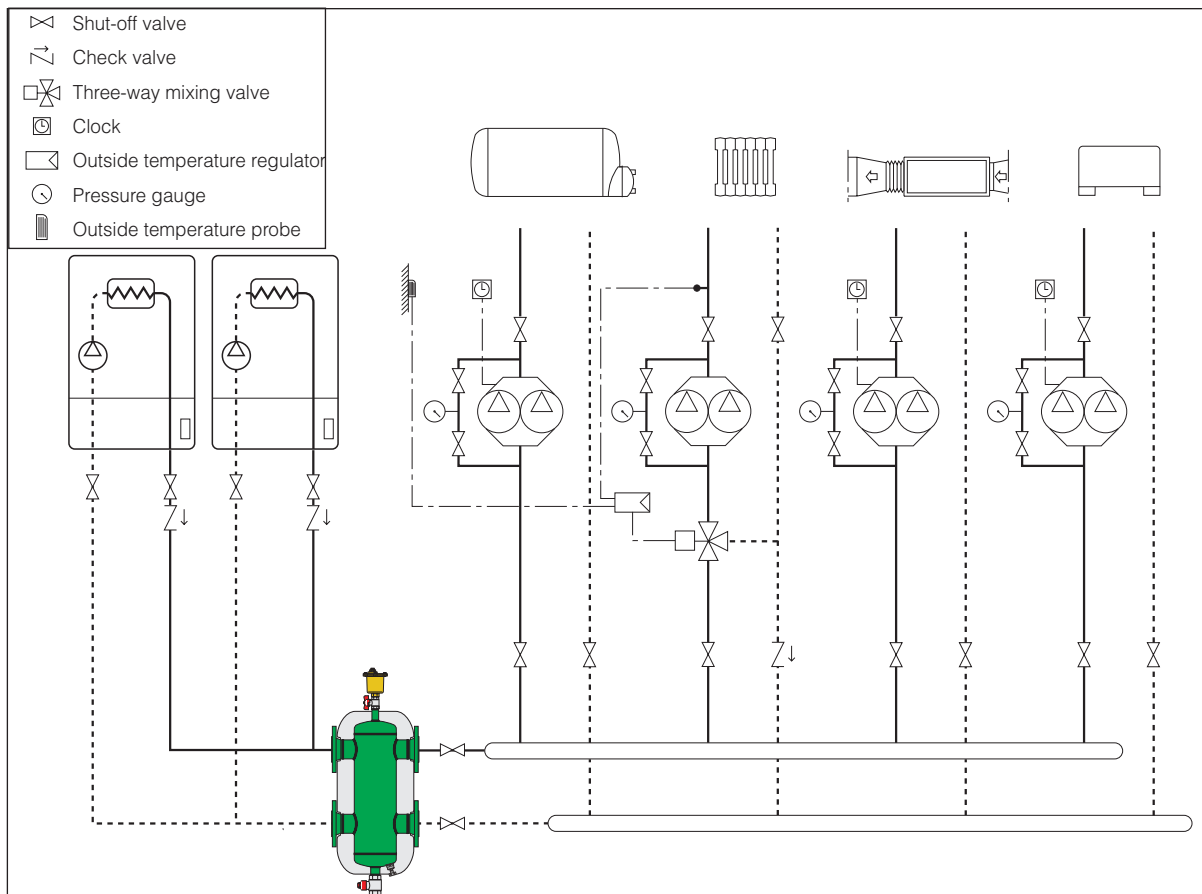

## Accessories



Temperature pocket well kit fits 1", 1-¼", 1-½" and 2" SEP4 5495 series separators, 1-¾" pocket length, inside thread 20 x 1.0 mm, ½" straight thread external thread. Includes pocket well, rubber grommet to hold sensor bulb in place, and sealing washer.

NA10425

## SPECIFICATION SUMMARY

### SEP4™ 5495 series with union connections

Combination hydraulic, air, dirt and magnetic separator. Sweat, NPT female and press connections with unions, 1", 1¼", 1½" and 2". Epoxy resin painted steel body. HDPE internal elements, removable for cleaning. Temperature range 32–210°F (0–100°C) with insulation or 32–230°F (0–110°C) without insulation. Water or glycol solution to 50% maximum. Maximum working pressure 150 psi (10 bar). External removable magnet belt, neodymium rare-earth. Air separation efficiency: 100% removal to microbubble level. Particle separation capacity: 5 µm (0.2 mil). Ferrous impurities separation efficiency: up to 100% removal. Supplied with code 59829 brass air vent with stainless steel float linkages and float guide pin, EPDM hydraulic seal and PP float and brass drain valve with hose connection. Pre-formed insulation shell is closed-cell expanded PE-X. Thermometer well pocket connection ½" straight female thread. Provide temperature pocket well kit, code NA10425.

### SEP4 5495 series with Flanged connections

Combination hydraulic, air, dirt and magnetic separator. ANSI B16.5 CLASS 150 RF flanged connections 2", 2½", 3", and 4". Epoxy resin painted steel body with brass drywell for external removable neodymium rare-earth magnet, code F0000435 for 2", 2½", code 49684A for 3" to 6", included. 300 series stainless steel internal coalescing mesh. Vessel working temperature range of 32–220°F (0–105°C) with insulation, 32–270°F (0–132°C) without insulation. Water or glycol solution to 50% maximum. Max. working pressure 150 psi (10 bar). Air separation efficiency: 100% removal to microbubble level. Particle separation capacity: µm (0.2 mil). Ferrous impurities separation efficiency: up to 100% removal. Supplied with: code 501502A automatic air vent with ¾" NPT female outlet connection and brass body VITON air vent seal and stainless steel air vent float. Code NA39589 brass body ¾" NPT female shut-off ball valve with T-handle for air vent. Code NA39753 lever-operated drain ball valve brass body with 1" NPT female connection. Rigid closed cell expanded polyurethane foam shell insulation with external embossed aluminium cover.

### SEP4 NA549\_M series with Flanged connections

Combination hydraulic, air, dirt and magnetic separator. ANSI B16.5 CLASS 150 RF flanged connections 2", 2½", 3", and 4". Epoxy resin painted steel body with brass drywell for external removable neodymium rare-earth magnet, code F0000435 for 2", 2½", code 49684A for 3" to 4", included. 300 series stainless steel internal coalescing mesh. Vessel working temperature range of 32–220°F (0–105°C) with insulation, 32–270°F (0–132°C) without insulation. Water or glycol solution to 50% maximum. Max. working pressure 150 psi (10 bar). Air separation efficiency: 100% removal to microbubble level. Particle separation capacity: µm (0.2 mil). Ferrous impurities separation efficiency: up to 100% removal. Supplied with: code 501502A automatic air vent with ¾" NPT female outlet connection and brass body VITON air vent seal and stainless steel air vent float. Code NA39589 brass body ¾" NPT female shut-off ball valve with T-handle for air vent. Code NA39753 lever-operated drain ball valve brass body with 1" NPT female connection. Rigid closed cell expanded polyurethane foam shell insulation with external embossed aluminium cover. The separator is designed and built in accordance Section VIII, Division 1 of the ASME Boiler and Pressure Vessel Code and tagged and registered with the National Board of Boiler and Pressure Vessel Inspector, and CRN registered, and stamped for 150 psi (10 bar) working pressure, with ASME U stamp.

### SEP4 NA549\_M series with Flanged connections

Combination hydraulic, air, dirt and magnetic separator. ANSI B16.5 CLASS 150 RF flanged connections 5", 6", 8", 10", 12" and 14". Epoxy resin painted steel body with brass drywell for external removable neodymium rare-earth magnet, (quantity one for 5" and 6" sizes-code 49684A, quantity three for 8" - 14" sizes-code F0000349) included. 300 series stainless steel internal coalescing mesh. Vessel working temperature range of 32–220°F (0–105°C) with insulation, 32–270°F (0–132°C) without insulation. Water or glycol solution to 50% maximum. Max. working pressure 150 psi (10 bar). Air separation efficiency: 100% removal to microbubble level. Particle separation capacity: µm (0.2 mil). Ferrous impurities separation efficiency: up to 100% removal. Supplied with: code 501502A automatic air vent with ¾" NPT female outlet connection and brass body VITON air vent seal and stainless steel air vent float. Code NA39589 brass body ¾" NPT female shut-off ball valve with T-handle for air vent. Lever-operated drain ball valve brass body with 1¼" NPT female connection for separator sizes 5" and 6" - code NA39588; 2" NPT female connection for separator sizes 8" - 14", code NA59600. For separator size 8" - 14" only thermometer pocket well on front center ¾" NPT female; and on inlet/outlet flanges ½" NPT female. The separator is designed and built in accordance Section VIII, Division 1 of the ASME Boiler and Pressure Vessel Code and tagged and registered with the National Board of Boiler and Pressure Vessel Inspector, and CRN registered (size 8" - 14" pending, contact Caleffi), and stamped for 150 psi (10 bar) working pressure, with ASME U stamp.

We reserve the right to change our products and their relevant technical data, contained in this publication, at any time and without prior notice.



Caleffi North America, Inc.  
3883 W. Milwaukee Road  
Milwaukee, WI 53208  
Tel: 414-238-2360 · Fax: 414-238-2366  
sales@caleffi.com · www.caleffi.com  
© Copyright 2019 Caleffi North America, Inc.