

AFRISO EURO-INDEX

Meß-, Regel-, Überwachungs-
geräte für Heizungstechnik,
Industrie und Umweltschutz
Lindenstraße 20
74363 Güglingen
Tel. ++49(0)7135-102-0
Fax ++49(0)7135-102-147
Internet: www.afriso.de
e-mail: info@afriso.de

Operating Instructions

Flow-Control 3/K-1

TÜV-tested: No. S50/97

Art.-Nr.: **69942**

- + Read before use!
- + Take note of all Safety Directions!
- + Retain for future use!

Issue: 30.07.2003
Id.-No.: 854.000.0351



1 Application

The single-pipe system for fuel oil burners may cause problems during suction operation in terms of the air that is released when the oil is removed from the tank. This air may result in burner malfunctions or burner lockout if the air forms large bubbles.

Suction operation of the single-pipe system requires a permanently active oil de-aerator.

When Flow-Control is installed with a single-pipe system, the excess return oil not fed through the nozzle is directed to Flow-Control where it is de-aerated. This air-free oil is then fed back to the pump via the suction pipe, which, in single-pipe operation, delivers only the amount of oil actually used by the nozzle.

The amount of air and the pipe resistance are reduced. The dimension of the suction pipe must be adapted to the single-pipe system.

2 Technical data

Pump connections	¼-NPT inner thread
Tank connection	¼-NPT inner thread
Nozzle capacity	max. 18.5 gph
Return oil pumped into Flow-Control	max. 37 gph
Oil flow	max. 50 gph
Separating capacity	up to 4 l/h
Ambient temperature	max. 140°F (60°C)
Operating temperature	max. 140°F (60°C)

Operating suction pressure (low air pressure)	max. 7.5 psi
Operating overpressure	max. 10 psi
Pressure test of pipe system	max. 85 psi
Dimensions	3.74"x3.74"x5.73" in (95x95x146mm)
Mounting position:	floatchamber pointing vertically to the top

3 Description and function

Flow-Control consists of a die-cast zinc body with the connections for the pipe from the tank, the pump suction pipe and the pump return pipe.

A float chamber is mounted to the zinc body of Flow-Control. It contains the float plus an additional safety float. The upper (safety) float supports and controls the de-aerator valve that is located on top of the housing.

The burner pump draws the fuel oil from the tank via the check valve in the bottom of the housing and delivers it to the nozzle. The excess oil not used by the nozzle is pumped into the float chamber via the Flow-Control pipe connection for the return pipe. While the oil level gradually increases in the float chamber, the oil is de-aerated.

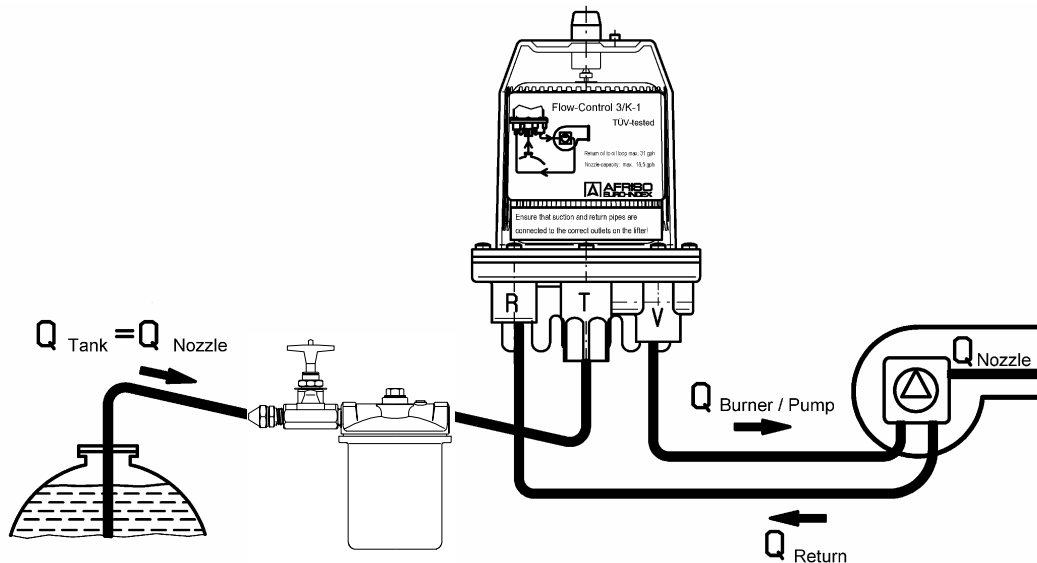

When the oil reaches a level of approx. 1 3/16" above the bottom, the float begins to operate and opens the bottom valve, thus delivering the oil collected in the float chamber to the suction pipe. During normal operation, the upper part of the housing is empty, the de-aeration hole is open and there is no pressure in the housing.

The de-aeration valve is equipped with a proven V ring lip seal. If the regular float does not operate, the rising oil activates the safety float that closes the de-aeration hole.

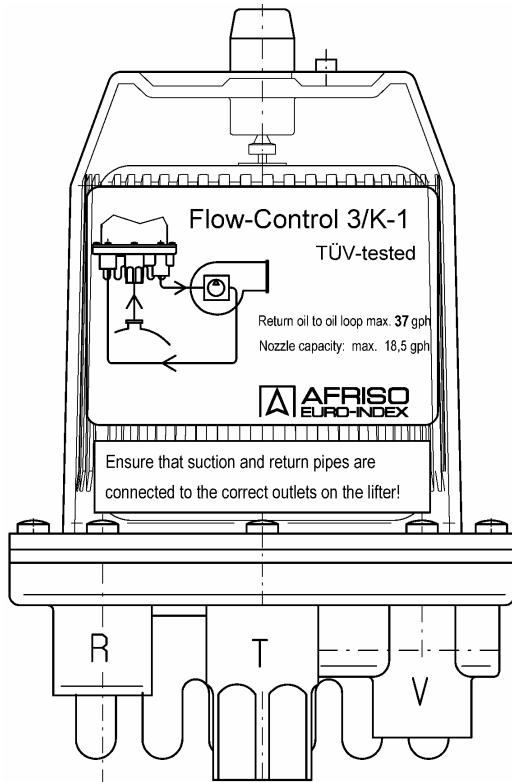

4 Installation instructions

Flow-Control is installed between the burner and the shut-off valve, close to the oil burner. However, Flow-Control must not be used in ambient temperatures greater than 140°F. Do not mount the unit in the vicinity of uninsulated burners, over burner opening flaps or next to chimney flues.

The float chamber must be mounted vertically, pointing to the top. Use oil lines as per local codes for connection to the oil pump. Please ensure that the pump is set for two-pipe operation (bypass plug installed) when mounting the unit. An oil filter

must be installed in the supply line in order to protect Flow-Control.

A 3/8" pipe is sufficient for most installations. In larger systems requiring 1/2" pipes (if the consumption is less than 5 1/4 gph), all parts of the pipes leading upwards should be calculated as suction height. If the suction pipes are larger than 1/2", this should be taken into consideration as well (even if the consumption amounts to more than 5 1/4 gph). Large pipes with low flow rates may cause gas accumulations, resulting in insufficient suction in the downward sections.

Flow-Control 3/K-1 must be mounted as shown in figures on the left.

Check valves between the Flow-Control and the tank must be removed. All pipework must be tested during installation.

Caution

1. Use only No. 2 oil or lighter.
2. Install the oil de-aerator in an upright position so it fits securely and cannot come loose.
3. A professional expert may only perform installation. Law or building codes may require inspection by local or federal authorities.
4. Never use the Flow-Control with pump pressure between tank and Flow-Control.
5. When the oil tank is positioned higher than the oil de-aerator, we strongly recommend the installation of a melt (fusible) valve or an OSV valve on the feed line from the tank. In case of fire, these valves will prevent oil from running out and intensifying the fire.
6. Never install a shut-off valve or other device, which can impede flow in the lines between the oil de-aerator and the oil pump.
7. The completed installation must be tested for correct function and fire security before starting.
8. Only one fuel unit per Flow-Control connection.
9. Bypass plug must be installed.

5 Right dimension of the suction tube

Standard values for the tube dimensioning:

Volume flow in the suction tube	Tubing size Copper
0 - 13 gph	5/16"
8 - 24 gph	3/8"
18 - 37 gph	1/2"

6 Notes

- When performing a pressure test of the suction line, you must not make the pressure connection to Flow-Control. The integrated check valve will not allow the pressure to be applied to the suction pipe. Therefore, it is not to be included in the pressure test.

7 Oil foam

If the amount of air reaching Flow-Control exceeds the maximum separating capacity (i.e. 4 l/h max), oil foam may be generated.

Possible reasons:

- leak in the suction pipe
- starting up (without separate suction pump)
- suction pipe too large

Note: In single-pipe mode, only the amount consumed by the burner is transported through the suction pipe!

8 The Flow-Control is completely filled with oil.

This can happen when there is pressure in the feed line (tank higher than burner), but it will not affect the function of the pump. By installing an Oil Safety Valve (OSV) on the feed line from the tank, the oil level will resume its normal level in the Flow-Control.

9 Optional accessory against oil smell in the house

To avoid nuisances odor through the deposited air (for example during the mounting in kitchens), onto the top of the flow control an insert can be screwed. The nipple is screwed onto the peg of the bonnet with the aid of a 19 mm open-ended wrench until the O ring presses against the flat surface of the bonnet. The other end of the PE hose is attached to the insert and/or to the return pipe connection of the draw-off system of the tank to be sure that the hose will be open in the future. The connection to the return pipe connection from the draw-off system can be made with a standard pneumatics screw joint.

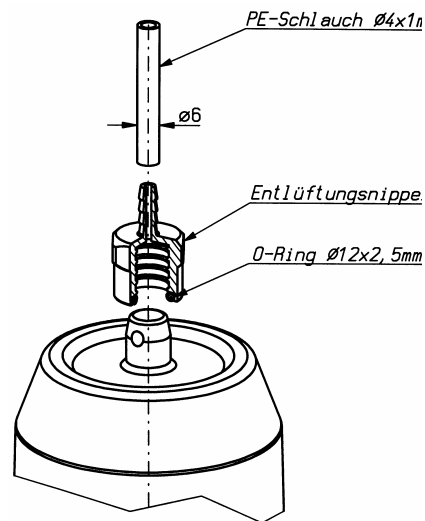

10 Parallel connection of two Flow-Control

The built-in check valve permits connection of several oil burners to the same feed line. In this case, the total oil consumption must be used when calculating this pipe resistance. For larger capacities, two or more Flow-Control can be connected in parallel (see picture).

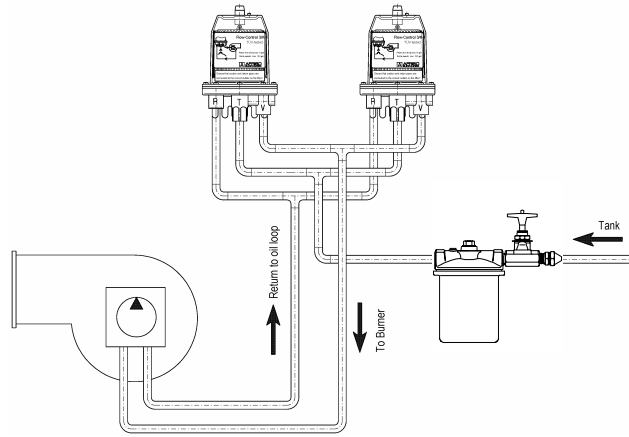

11 Reference

Example:

Install the Anti-siphon Valve as per manufacturers recommendations.

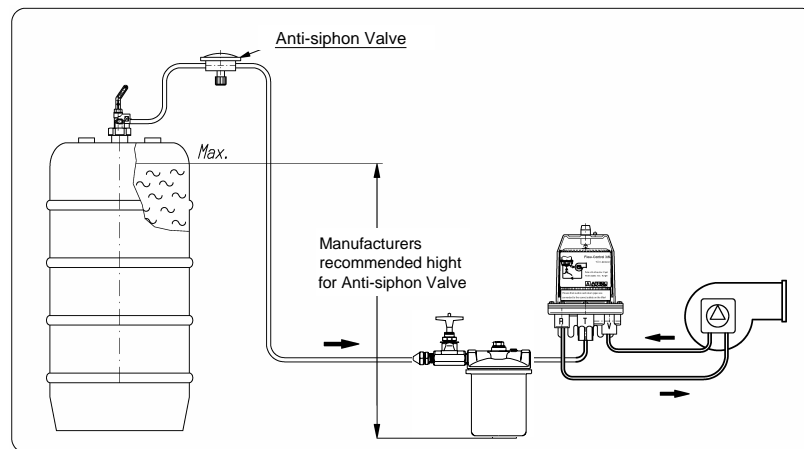

Burner should be installed a maximum of 15 feet above the bottom of the oil pickup tube.

