



MONARCH NOZZLES

Oil burner nozzles | Industrial Oil Nozzles | Water Nozzles



ATOMIZING NOZZLES | HOLLOW CONE NOZZLES | SOLID CONE NOZZLES | FLAT SPRAY NOZZLES



MONARCH NOZZLES

7249-B Browning Road
Pennsauken, NJ 08109

Email: hbeccari@monarchnozzles.com
Phone: 1-856-241-1500



MONARCH Nozzles

Monarch... Your first choice for spray nozzles. Time tested quality! Today and always!

MONARCH HISTORY

Since its founding in 1916 MONARCH Manufacturing produces spray nozzles and accessories for many different applications in industry and agriculture. In 1933, the export business tackled and has continued to represent an important part of our business. Meanwhile, there are general agencies abroad and distributors in many other countries.

MONARCH QUALITY

Because of product durability and consistently high quality MONARCH has acquired a reputation worldwide. An experienced staff ensures that each design and demand can be achieved.

MONARCH PROMISE

The wide range of nozzles is either as a finished product ready for immediate shipment or unwrought stock to be completed immediately to customer specifications. MONARCH is able to submit short term deals on special designs. The development department available to customers on new applications with words and deeds.



Monarch's plant in Philadelphia in the 1930s.

Imprint

Published
Publisher Details

01.08.2017

©MONARCH NOZZLES

7249-B Browning Road
Pennsauken, NJ 08109

Email: hbeccari@monarchnozzles.com
Phone: 1-856-241-1500



OVERVIEW

MONARCH PRODUCTS

MONARCH QUALITY, FAQ'S and ORDER INFORMATION	04
NOZZLE BASICS	05
FIND YOUR APPLICATION	06
OIL BURNER NOZZLES	08
Series PL, PLP, R, HV, AR, NS	08
HO	10
INDUSTRIAL OIL NOZZLES	12
BPS	12
C-169 / 170 -WA	14
C-202 Air Operated Nozzle	16
C-206 Air Operated Nozzle	17
D-41-H	18
E-180-H	20
AAMA test nozzles	22
B-25 large capacity AAMA Nozzle	22
WATER NOZZLES	24
629 / 631 non-clog (wide angle)	24
F-80-W.	26
H-261 (-CJ)	27
H-530	28
H-535	29
H-545	30
H-601 air operated	31
H-837 solid jet nozzles	32
MIDGET	33
M2P Plastic	34
CARBON BLACK NOZZLES	35
F-94	35
ACCESSORIES	36
AAMA Kit, Nozzle Remover, Nozzle Case, PVC Tee, Multiple Nozzle Adaptors, No Drip Strainer Check Valve, Pump Test kit	36



NOZZLE BASICS

FREQUENTLY ASKED QUESTIONS

QUALITY TESTING :..Each nozzle is individually spray tested for spray angle, quality and balance. All tests are made at 150 PSI or 10 bar pressure.

NOZZLE INTERCHANGE CHART

NOTE: the information can only be used as a guide to selecting the nearest comparable MONARCH Nozzle. No guarantee can be made that the nozzles indicated are exact equivalents in regard to either spray angle or spray pattern.

Nozzle Interchange Chart		
	Type	MONARCH EQUIVALENT
DELAVAN	A B W DEL-O-FLO CF	NS or PL R or PLP AR R or NS CC
HAGO	ES H SS P	R or AR NS or PL PLP R or PLP
STEINEN	H PH Q S SS	NS PL AR F PLP
DANFOSS	H B S	NS or PL AR PLP or R

WARRANTY

All Material is guaranteed to be free from defects in workmanship and material.

Parts believed to be defective should be returned with an authorized RGA from the factory. If our inspections confirms buyers claim, material will be either repaired or replaced, at our option, and credit issued for the shipping charges. Disassembly of the nozzle unit voids the implied warranty.

Monarch accepts no responsibility for defective workmanship or material other than the repair or replacement of the item under either express or implied warranty.



NOZZLE BASICS

EXPLANATION OF TERMS | Glossary

CONE SPRAY

Nozzles whose spray is emitted in a conical shape and a round cross section. Cone sprays have less impact than flat sprays and are therefore better suited for rinsing and wetting.

SOLID CONE SPRAY NOZZLES

Good all-round nozzle suitable for most burners.

HOLLOW CONE SPRAY NOZZLES

Cone Spray Nozzles in which the cross section distribution shows little or no droplets in the center and with most of the spray concentrated at the outer edge.

FLAT SPRAYS

Also known as fan sprays, these Nozzles produce either a flat or elliptical sheet of water. They are best suited for washing operations where high impact is desirable. The spray normally breaks into individual droplets a few inches from the orifice.

ATOMIZING NOZZLES

Produce a highly atomized hollow cone spray. Their light mist ranges from a fog that hangs in the air to slightly larger droplets that fall by gravity. They are most typically used for humidification and very light wetting.

JET NOZZLES

Produce a straight unbroken stream of water nominally referred to as a 0° spray angle. Depending on the piping set up, orifice size and water pressure, the stream may remain unbroken from a few inches up to 3 or 4 feet. For blasting and light cutting applications.

GPH

Gallons per hour (gallons per hour: 1 gallon = 3.7853 l). This size unit is always based on water flow. See the table for a given nozzle to determine the pressure of her flow.

SPRAY ANGLE

The included angle of the spray emitted from the Nozzle orifice. This excludes the light "fuzz" at the edge of some sprays, particularly those of low flow rates. Higher operating pressures usually tend to compress the

spray, thereby resulting in a narrower spray angle. Liquids with surface tensions lower than water will produce wider spray angles than those of water. See chart on page 16 for coverage data.

ORIFICE

The aperture through which the liquid exits the Nozzle. It meters the liquid and its contours produce the various spray angles. It is normally round but can be elliptical in the case of flat spray Nozzles. On most Nozzles the orifice is a highly polished surface. It should never be probed with any metal object. A wooden toothpick is the best tool for cleaning or unclogging an orifice

NOZZLE OPENING

The aperture through which the liquid exits the Nozzle. It measures the liquid and its contours produce the various spray angles. It is normally round but can be elliptical in the case of flat spray Nozzles. On most Nozzles the orifice is a highly polished surface. It should never be probed with any metal object. A wooden toothpick is the best tool for cleaning or unclogging an orifice.

PRESSURE

The force of the liquid entering the Nozzle expressed in PSI (pounds per square inch). In general, operating at higher pressures produces smaller droplets, narrower spray angles and more solid patterns. Conversely, lower pressures result in larger droplets, slightly wider angles and less dense distribution.

MINIMUM OPERATING PRESSURE

Lowest possible pressure at which the kinetic energy of the liquid is sufficient to produce a fully developed jet. Data flow in the nozzle tables indicate that value for water. He can be higher or lower if other fluids are used as water because it depends on the specific weight and Viscosity of the liquid.

NPT

National Pipe Thread (American standard pipe thread). This is a tapering thread that participates in the installation of self-

tightening. A thread seal as "pipe dope or Teflon tape is needed in order to seal properly.

CFM

Cubic feet per minute (cubic foot per minute). A unit of measurement describing the volume of gas (usually air) flowing to an air operated Nozzle.

SPRAY ATOMIZATION

A Spray Nozzle breaks up a flow of liquid into many small droplets. The efficiency, or results, of the spray process greatly depend on droplet size and distribution. Droplet size may range from a few to thousands of microns in diameter depending upon the liquid being sprayed, the pressure and Nozzle design. Nozzles do not generate droplets of equal size. There is usually a broad spectrum of droplet sizes within a spray. Larger droplets occur as nozzle capacity increases. Coarse atomization is often associated with narrow angles or straight streams. For a given nozzle, fineness of atomization may be improved by increasing pressure. The two important liquid parameters affecting atomization are viscosity and surface tension. Compared with viscosity, surface tension has a relatively minor affect.

SPRAY VELOCITY

The velocity of the spray leaving a Nozzle orifice depends upon the liquid pressure. The velocity is also determined by the design characteristics of the specific Nozzle. Solid stream and flat spray Nozzles will have, under equal conditions, higher velocities than wide angle, round cone Nozzles.

GPM

Gallons per minute (gallons per minute). The unit size for nozzles with a larger flow rate, based on water flow. See the table for a given nozzle to determine the pressure of her flow.

NOTE

Some of our Nozzles that are listed as solid cones can actually be made to produce a hollow cone spray although not specifically listed. If a particular Nozzle configuration suits your requirements but is the wrong

nominal spray pattern, let us know of your needs and we'll be glad to let you know if we can meet your need.

ORDERING INFORMATION

State quantity, Nozzle type, Nozzle number, spray angle, material, size and type pipe connection (Male or female) and either "tips only" or "complete" Nozzles. Nozzles type designations are shown in the upper corner of each page. (F-80, H-535, etc.).

WARRANTY

All material is guaranteed to be free from defects in workmanship and materials. Parts believed defective should be returned prepaid. If our inspection confirms buyer's claim, material will be either repaired or replaced, at our option, and credit issued for the shipping charges. Monarch accepts no responsibility for defective workmanship or material other than repair or replacement of the item under either express or implied warranty.

NOZZLE SERVICING

Nozzle orifices are highly polished surfaces which are easily damaged. Pins, needles or other sharp objects should never be used to clean an orifice. A sharpened wooden toothpick is suggested. For calcium build-up from alkaline water, it is suggested that the Nozzles be soaked overnight in inhibited muriatic acid or vinegar. This is usually sufficient to restore the Nozzle serviceability.



APPLICATIONS

MONARCH PRODUCTS



SPECIAL APPLICATIONS

We design and develop custom Nozzles with custom Spray Patterns for a wide range of applications. Feel free and **ask us for your special application!**

EXAMPLES

- Showers
- Tanning, Poultry Desinfection
- Grey water
- Cereal Flavoring + Nutrients
- Food Applications
- Bakery
- Icing
- Fillings
- Poultry growth
- Humidity control
- Powerstream generators
- Global supplier for GE

METHANOL INJECTION FOR RACECARS

Alcohol / Methan
Increase of horsepower and torque
Diesel Injection for trucks, RV, farm equipment

BUILDING TESTING

Curtain wall leakage
Spray rack coverage
Window Certification
Dust suppression

CLEANING

Car and Truck Washing
Carpet steaming
Manifold degreasing

HIGHWAY

Asphalt spraying
Line painting
Weed kill

CUSTOM DESIGNS

Reptile / Crocodile
Butterfly
Rain forest
Cool zones - amusement parks
Patio cooling
Insect repel
Special effects
Cooling towers
Snow making canons
Hog cooling
Automotive
Dust suppression
Fire halon spray

RECOMMENDED USAGES

These following applications are general recommendations. Consult factory for specific applications.

NOZZLE APPLICATIONS (right)

Sorted from A ... Z | A - Atomizing F - Flat Spray H - Hollow Cone S - Solide Cone



APPLICATIONS

MONARCH PRODUCTS

Application	Spray Pattern	Nozzle Type
Absorption Towers	S	B-25
Aerating	H H	629 / 631 B-8-A
Air Conditioning	A A	F-80 H-261
Air Purification	H	629 / 631
Air Washers	H	629 / 631
Asphalt Spreading	H H F	629 / 631 B-8-A H-545
Bottle Cleaning / Washing	F F F	H-535 H-545 F-94
Brine Spraying	S	B-25
Butcher Pork Cooling	A	Midget
Car Washing	F	F-133 / 134
Carbon Black Manufacturing	S	F-94
Cleaning (General Application) / Parts Cleaning / Washing	F F S	H-535 H-545-R H-837
Coil Defrosting (Snow and Ice Removal)	A A	F-80 H-261
Cooling Ponds	H S	B-8-A B-25
Cooling Tower	H S	629 / 631 B-25
Crop Spraying	F	F-96
Curtain Wall Testing	S A	B-25 H-261
Cutting	S	H-837
Dampening	A A	F-80 H-261
Degreasing	S H F F	H-837 629 / 631 H-535 H-545
Dish Washing	S F F	H-261-CJ H-535 H-545
Drying Towers	S	B-25
Evaporative Cooling	A A A	F-80 Midget H-261
Extrusion Cooling	A A A	F-80 H-261 Midget
Fertilizer Application	S	F-94
Flame Retardation	S S	B-25 H-530
Foam Control	S F	B-25 H-545
Food Processing	S A A	F-94 F-80 H-261
Freeze / Frost Protection / Prevention	A A A	F-80 H-261 Midget

Application	Spray Pattern	Nozzle Type
Gas Cooling	H S	629 / 631 B-25
Gas Pipe Testing	S A	B-25 H-261
Gas Scrubbing	S S	F-94 H-530
Gas Washer	S S	F-94 H-530
Gravel Laundry / Washing	H S	629 / 631 B-25
Greenhouse Air Humidification	A	Midget
Hog Cooling	A	Midget
Humidification	A A A S	F-80 H-261 Midget H-601
Insecticide Application	F	F-96
Metal Cleaning	S F F	H-837 H-535 H-545
Misting	A A A A S	F-80 H-261 F-97 Midget H-601
Moistening	A A	F-80 H-261
Paper Pulp Processing	H	B-8-A
Pesticide Application	F	F-96
Poultry Cooling (Atomization), Misting	A	Midget
Quenching	S S	H-530 B-25
Rinsing	A A F F	F-80 H-261 H-535 H-545
Roof & Rooftop Cooling	H	629 / 631
Salt Solution Spray	S	B-25
Soot-black Production	S	F-94
Swine Cooling	A	Midget
Tank Cleaning	F	H-545-R2
Ventilate	H	629 / 631
Water Atomization	A A A S	F-80 Midget H-261 H-601
Wax Spraying	A A	F-80 H-261
Weed Control	F H	F-96 629 / 631
Window Testing	S A	B-25 H-261



OIL BURNER NOZZLES

Atomizing Nozzle for a wide range of applications



OIL BURNER NOZZLE

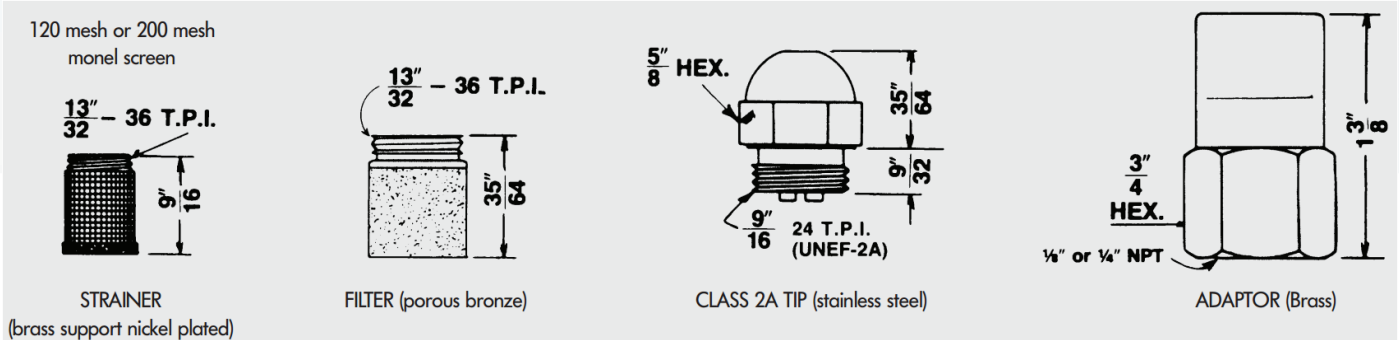

OIL BURNER NOZZLES

Monarch produces oil burner nozzles for all oils with viscosity to 5 mm²/s (cSt). Special nozzles can be used for oils with a viscosity up to 13 mm²/s (cSt).

All MONARCH nozzles are stamped with the following characteristics, subject to modification on adoption of CEN standards:

- the flow (in USGPH at 100 PSI = 6.895 bar), (soon, capacity at 10 bar and CEN references)
- spray angle
- letters to identify the series of spray patterns
- the reference MTD-92
- the MONARCH trade mark.

Each MONARCH MTD-92 nozzle is individually tested at several different production stages to assure perfect conformity with master nozzles of each series.

The spray patterns (i.e. hollowcone or solid cone) described below refer to the tests carried out with a 60° angle at a 75 mm distance from the nozzle orifice. In nozzles of a 60° spray angle or less, and for low flows in particular, the empty section of a hollow cone becomes smaller. The difference between hollow cone and solid cone practically disappears.

Solid Cone "R" Series: .40 to 3.50 USGPH

This is the series supplied regularly unless customer specifies otherwise. It is a good all-round nozzle suitable for most burners. Atomization of the oil is not quite as fine as with the "NS" series.

HollowCone "NS" Series: .50 to 2.00 USGPH

This Series works best on many burners due to its exceptionally fine atomization. Produces a quiet stable flame. Widely used in 80° and 90° on flame retention burners.

SpecialSolid Cone "AR" Series: .50 to 3.50 USGPH

This series has become widely used due to its success in obtaining quiet combustion in some flame retention head burners. Traditionally a "cure-all" replacement nozzle, it now is increasingly specified on original equipment.

Semi-SolidCone "PLP" Series: 2.25 to 100.00 USGPH

The standard nozzle for larger capacities. Fine atomization and "solid" spray pattern up to about 3.50 USGPH, gradually becoming more and more "hollow" in the larger sizes.

HollowCone "PL" Series: 2.25 to 50.00 USGPH

This series represents an extension of the "NS" type spray pattern to larger capacity sizes. Spray is not as finely atomized as the "PLP" series, but produces the best results in equipment specifying hollow cone nozzles.

NarrowSpray Angle "HV" Series: 1.65 to 60.00 USGPH

Used mostly for Semi-Industrial or Scotch Marine applications where narrow spray angle and high spray velocity is essential and some combustion noise is not objectionable.

Heavy OilNozzle "HO" Series: 1.25 to 100.00 USGPH

Designed for use on 70 SSU (approx. 13 centistokes) operating viscosity oil at operating pressures ranging from 200-450 PSIG (13.8 to 31 bar).

SPRAY PATTERNS



R

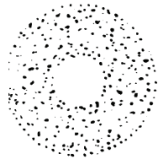

NS



AR



PLP



PL



HV



OIL BURNER NOZZLES

Atomizing Nozzle for a wide range of applications



OIL BURNER NOZZLE

Minimum Capacity: Gallons Per Hour							
Size	15	75	100	125	150	175	200
0,4	-	-	0,4	0,4	0,5	0,5	0,6
0,5	-	-	0,4	0,5	0,5	0,6	0,6
0,5	-	-	0,5	0,6	0,6	0,7	0,7
0,6	-	-	0,5	0,6	0,7	0,7	0,8
0,6	-	-	0,6	0,7	0,7	0,8	0,8
0,7	-	-	0,6	0,7	0,8	0,8	0,9
0,8	-	-	0,7	0,8	0,9	1,0	1,0
0,9	-	-	0,8	0,9	1,0	1,1	1,2
1,0	0,4	0,9	1,0	1,1	1,2	1,3	1,4
1,1	0,4	0,9	1,1	1,2	1,3	1,4	1,5
1,2	0,4	1,0	1,2	1,3	1,4	1,6	1,7
1,3	0,5	1,1	1,2	1,4	1,5	1,6	1,7
1,4	0,5	1,2	1,3	1,5	1,6	1,8	1,9
1,5	0,6	1,3	1,5	1,7	1,8	1,9	2,1
1,7	0,6	1,4	1,6	1,7	2,0	2,1	2,3
1,8	0,7	1,5	1,7	1,9	2,1	2,3	2,4
2,0	0,7	1,7	2,0	2,2	2,4	2,6	2,8
2,3	0,8	1,9	2,2	2,5	2,7	2,9	3,1
2,5	0,9	2,1	2,5	2,8	3,0	3,3	3,5
3,0	1,1	2,5	3,0	3,3	3,6	3,9	4,2
3,5	1,3	3,0	3,4	3,8	4,2	4,6	4,9
4,0	1,5	3,4	3,9	4,4	4,8	5,2	5,6
4,5	1,7	3,8	4,4	5,0	5,4	5,9	6,2
5,0	1,9	4,3	4,9	5,5	6,0	6,5	6,9
5,5	2,0	4,7	5,4	6,1	6,6	7,2	7,6
6,0	2,2	5,1	5,9	6,6	7,2	7,8	8,3
6,5	2,4	5,5	6,4	7,2	7,8	8,5	9,0
7,0	2,6	6,0	6,9	7,7	8,5	9,1	9,8
7,5	2,8	6,4	7,4	8,2	9,0	9,8	10,4
8,0	3,0	6,8	7,9	8,8	9,6	10,5	11,1
8,5	3,1	7,2	8,4	9,4	10,3	11,1	11,9
9,0	3,3	7,7	8,8	9,9	10,8	11,7	12,5
9,5	3,5	8,1	9,4	10,4	11,5	12,4	13,3
10,0	3,7	8,5	9,8	11,0	12,1	13,0	13,9
10,5	3,9	8,9	10,3	11,5	12,7	13,7	14,7
11,0	4,1	9,4	10,8	12,1	13,3	14,3	15,3

Minimum Capacity: Gallons Per Hour							
Size	15	75	100	125	150	175	200
11,5	4,3	9,8	11,3	12,6	13,9	15,0	16,0
12,0	4,4	10,3	11,8	13,2	14,5	15,7	16,7
12,5	4,6	10,7	12,3	13,7	15,1	16,3	17,4
13,0	4,8	11,1	12,8	14,3	15,7	16,9	18,1
13,5	5,0	11,5	13,3	14,8	16,3	17,6	18,9
14,0	5,2	11,9	13,8	15,4	16,9	18,2	19,5
14,5	5,4	12,4	14,3	15,9	17,5	18,9	20,2
15,0	5,6	12,8	14,8	16,5	18,1	19,5	20,9
15,5	5,8	13,2	15,3	17,1	18,6	20,2	21,5
16,0	5,9	13,6	15,8	17,6	19,2	20,9	22,3
17,0	6,2	14,3	16,7	18,7	20,5	22,2	23,8
17,5	6,5	14,8	17,2	19,3	21,1	22,8	24,4
18,0	6,7	15,3	17,7	19,9	21,6	23,4	25,0
19,0	7,1	16,3	18,7	20,9	23,0	24,8	26,6
19,5	7,2	16,6	19,2	21,5	23,5	25,4	27,2
20,0	7,4	17,1	19,7	22,0	24,1	26,0	27,8
20,5	7,6	17,5	20,2	22,5	24,8	26,7	28,5
21,0	7,8	17,9	20,6	23,0	25,4	27,4	29,3
21,5	8,0	18,3	21,2	23,6	26,0	28,0	29,9
22,0	8,2	18,7	21,6	24,2	26,5	28,6	30,6
23,0	8,5	19,7	22,6	25,3	27,7	30,0	32,0
24,0	8,9	20,5	23,6	26,4	28,9	31,3	33,5
25,0	9,3	21,4	24,5	27,5	30,1	32,3	34,8
28,0	10,4	23,8	27,6	30,8	33,7	36,4	39,0
29,0	10,8	24,7	28,5	31,9	35,0	37,7	40,4
30,0	11,1	25,6	29,5	33,1	36,2	39,1	41,8
35,0	13,0	29,8	34,5	38,5	42,2	45,6	48,7
40,0	14,9	34,1	39,4	44,0	48,2	52,2	55,6
45,0	16,7	38,4	44,3	49,7	54,3	58,6	62,7
50,0	18,5	42,6	49,2	55,0	60,3	65,1	69,6
55,0	20,5	46,9	54,1	60,5	66,3	71,6	76,5
60,0	22,4	51,2	59,0	65,9	72,3	78,1	82,7
70,0	26,1	59,6	66,3	77,0	84,3	91,0	97,4
80,0	29,8	68,1	78,7	88,0	96,5	104,3	111,7
90,0	33,5	76,6	88,6	99,3	108,7	117,3	125,5
100,0	37,3	85,1	98,4	110,1	120,6	130,2	139,2



HO

Oil burner Nozzle for higher viscosity oils



OIL BURNER NOZZLE

The HO series is offered to meet the requirement for Nozzles to be used on higher viscosity oils at elevated operating pressures. It is a redesignation of the PLO-HO, PL-HO and R-HO series to simplify specifications for ordering. These Nozzles (as with all Monarch Nozzles) are stamped with their nominal flow rate at 100 PSIG on #2 fuel oil and are available in capacity sizes from 1.00 through 100.0 GPH.

200 PSI: When regular light oil Nozzles are used on more viscous oil, their sprays tend to „flutter“, they produce a narrower spray angle and often develop streaks in the spray. Accordingly, the standard „HO“ Nozzles are specially tested for spray quality and rated for spray angle at a pressure of 200 PSIG (14 bars) on 70 SSU (13 Centistoke) operating viscosity oil. This special testing assures that the Nozzles will perform properly under heavy oil operating conditions. The spray angle stamped on the Nozzle is the nominal spray angle at 200 PSIG operating pressure.

430 PSI: For very high pressure operation, the HO Nozzles are also tested for spray angle and spray quality at 430 PSIG (30 bars) on 70 SSU operating viscosity oil. The special additional testing is necessary to be sure that no streaks, voids, or flutter appear in the spray at these pressures that would not appear at 200 PSIG. The spray angle stamped on the Nozzle is the nominal Spray Angle at 430 PSIG operating pressure.

The accompanying chart shows approximate flow rates when operating from 200 PSIG through 450 PSIG on 70 SSU operating viscosity oil, specific gravity .846. Note that the nominal flow rates stamped on the Nozzles are based on 100 PSIG using U.S. No. 2 fuel oil, subject to a flow tolerance of plus or minus 5%. Flow rates shown at 300 PSIG on 70 SSU operating viscosity oil are from actual tests. Flow rates at higher and lower pressures are rates predicted from the 300 PSIG data. Actual flow rates may vary, depending on exact operating conditions.

Nozzles for operation at 200 PSIG are available in 45°, 60° and 80° spray angles in sizes of 2.25 GPH up to, and including 45.00 GPH, and sizes of 50.00 GPH and up are available only in 60° and 80°. Nozzles for operation at 430 PSIG are available in 45°, 60° and 80° in sizes 1.00 GPH up to and including 45.00 GPH. Sizes of 50.00 GPH and up are available only in 80°.

Strainers are not included with Nozzles but 120 mesh Monel Strainers may be ordered separately. Strainers are specifically not recommended for use on sizes over 50.00 GPH, as restriction may occur.

MATERIAL

Models completely made of brass
416 SS would be available per request

PIPE CONNECTION

1/8 "NPT male

SPRAY ANGLES

"M": 80 °

"MW": 90 °, 120 °, 160 °

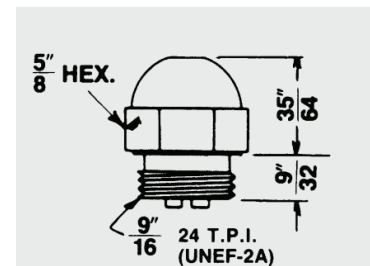

CAPACITIES & DIMENSIONS

Flow Rates

NOMINAL RATING #2 FUEL OIL*	U.S. Gallons Per Hour on 70 SSU Operatin Viscosity Oil Line Pressure (PSIG)						
	200	250	300	350	400	430	450
1.00	–	–	1.91	2.06	2.21	2.29	2.34
1.20	–	–	2.14	2.31	2.47	2.56	2.62
1.25	-	-	2.45	2.60	2.80	2.90	3.00
1.35	-	-	2.70	2.90	3.10	3.25	3.30
1.50	-	-	2.90	3.15	3.35	3.50	3.55
1.65	-	-	3.15	3.40	3.65	3.80	3.85
1.50	-	-	3.50	3.80	4.05	4.20	4.30
2.00	2.90	3.25	3.55	3.85	4.10	4.25	4.35
2.25	3.90	4.35	4.75	5.15	5.50	5.70	5.80
2.50	4.10	4.60	5.05	5.45	5.80	6.00	6.15
3.0	4.85	5.45	5.95	6.45	6.85	7.10	7.30
3.50	5.80	6.45	7.10	7.65	8.20	8.50	8.65
4.00	6.60	7.40	8.10	8.75	9.35	9.70	9.95
4.50	6.75	7.55	8.25	8.90	9.55	9.90	10.10
5.00	7.45	8.35	9.15	9.85	10.55	10.95	11.20
5.50	8.3	9.3	10.2	11.0	11.8	12.2	12.5
6.00	9.5	10.6	11.6	12.5	13.4	13.9	14.2
6.50	10.0	11.3	12.3	13.3	14.2	14.8	15.1
7.00	10.6	11.8	12.9	14.0	14.9	15.5	15.9
7.50	11.3	12.6	13.9	15.0	16.0	16.6	17.0
8.00	11.4	12.8	14.0	15.1	16.2	16.8	17.1
8.50	11.7	13.1	14.3	15.4	16.5	17.1	17.5
9.00	12.7	14.1	15.5	16.7	17.9	18.6	19.0
9.50	13.6	15.2	16.6	17.9	19.2	19.9	20.3
10.50	14.1	15.8	17.3	18.7	20.0	20.7	21.2
12.00	15.8	17.7	19.4	20.9	22.4	23.2	23.7
13.50	18.3	20.4	22.4	24.2	25.9	26.8	27.4
15.50	21.2	23.7	26.0	28.1	30.0	31.1	31.8
17.50	25.5	28.5	31.2	33.7	36.1	37.4	38.2
19.50	27.3	30.2	33.1	35.8	38.2	39.7	40.6
21.50	30.3	33.5	36.7	39.7	42.4	44.0	45.0
24.0	35.1	39.3	43.0	46.5	49.7	51.5	52.7
28.0	41.7	46.6	51.0	55.1	58.9	61.1	62.5
30.0	45.0	50.3	55.1	59.5	63.6	66.0	67.5
35.0	49.7	55.5	60.8	65.7	70.2	72.8	74.5
40.0	59.1	66.1	72.4	78.2	83.6	86.6	88.6
45.0	65.2	72.9	79.9	86.3	92.2	95.6	97.8
50.0	66.5	74.4	81.5	88.0	94.1	97.6	99.8
55.0	74.5	83.5	91.5	99.0	105.5	107.5	112.0
60.0	85.5	95.5	104.5	113.0	120.5	125.0	128.0
70.0	97.5	107.0	119.5	129.0	137.5	143.0	146.0
80.0	107.5	120.5	132.0	142.5	152.5	158.0	161.5
90.0	119.0	133.0	145.5	157.0	168.0	174.0	178.0
100.0	135.0	151.0	165.0	178.5	190.5	198.0	202.5

*Test Oil Specifications: U.S. No. 2 FUEL OIL: 4-36 SSU @ 100°F. 32-38 API Gravity @ 60°F
 Flow Tolerance: +/- 5% from stamped nominal rating @ 100 PSIG on U.S. No 2 Fuel Oil as specified at left



BPS BY-PASSING

By-passing nozzle



INDUSTRIAL OIL NOZZLE

The BPS nozzles produce variable orifice flow rates by by-passing fluid from the nozzle swirl chamber. The orifice flow is regulated by controlling the by-pass line pressure.

The nozzle tip and disc are made of the same heat resisting, high chrome grade of stainless steel used in our simplex or regular domestic oil burner nozzles. The combination locknut-strainer support is made of brass with a Monel strainer screen and a Viton „O” ring. Nozzle adaptors (bodies) and fittings are made of brass. Nozzles in all sizes are furnished only with strainers, 120 mesh Monel up to and including 13.50 GPH and 80 mesh on larger sizes.

The BPS nozzles are designed and tested for operation at 100 psi. on #2 fuel oil, with the capacity and spray angle stamped on the nozzles at these conditions. Both the capacity and spray angle rating are based on having the by-pass line closed. Spray angle widens 5°-10° with the by-pass wide open.

The chart shows the orifice flow rates at specific by-pass line pressures and also the maximum pressure in the by-pass line when the by-pass is closed.

The BPS nozzles can be supplied with spray angles as follows: 30° in capacities from 3.00 GPH up to and including 30.00 GPH; 45° in capacities from .75 GPH up to and including 35.00 GPH; 60° in all listed capacities, 80° in capacities from 1.50 GPH up to and including 35.00 GPH, and 90° from 10.50 GPH up to and including 24.00 GPH.

It is possible to operate standard BPS nozzles up to 250 psi. line pressure, and at this pressure they will handle up to 70 S.S.U. operating viscosity oil. The BPS nozzles can be specially tested for operation at line pressures of 300 psi or more at additional cost.

BY-PASS PRESSURES vs. ORIFICE FLOWS

Shown is a pressure-flow chart for the 6.00 GPH BPS nozzle operating at 100 psi. oil line pressure on #2 fuel oil. The total flow through the nozzle orifice and the by-pass line when the by-pass is completely open is considerably more than the rated capacity of the nozzle, per last column of chart above. For capacity sizes larger than those indicated as available, we refer you to the E-180-H.

DIMENSIONS

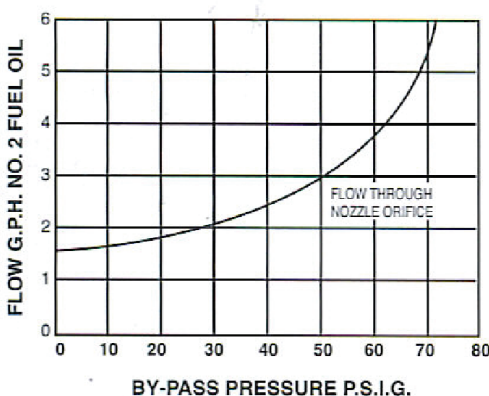
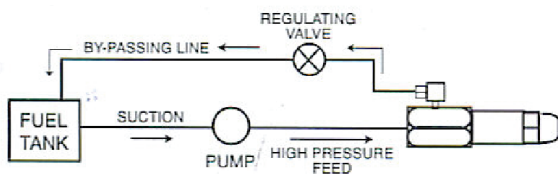

BY-PASSING NOZZLE ADAPTORS

The H-730-C by-passing nozzle adaptors are 2 1/16" long, made of 3/4" hexagon brass and are furnished with either 1/8" or 1/4" female N.P.T. oil inlet connections. They are equipped with a brass fitting on the side to accommodate 1/4" O.D. tubing for the by-pass line, and the distance between centers of the feed line and the by-pass line is 11/16". A dual by-passing adaptor, H-711, is also available to take two (2) BPS nozzles. Due to the necessity of combining inlet and by-passing flows of the two nozzles, the single inlet of the H-711 is 1/8" female N.P.T. located on the side of the adaptor and the single by-pass is 1/4" female N.P.T. located at the rear of the adaptor. The H-711 is made from 3/4" x 1 3/4" rectangular brass stock and is 2 1/8" long.

BPS BY-PASSING

By-passing nozzle

INDUSTRIAL OIL NOZZLE

CAPACITIES

Minimum Capacity: Gallons Per Hour						
Nozzle No.	Function Pressure – By Inch-pound limit				BY-PASS PRESSURE - BY-PASS CLOSED	TOTAL** FLOW: GPH TO NOZZLE BY-PASS OPEN
	By-Pass Pressure - PSIG					
	0	20	40	60		
.75	.20	.25	.75	-	40	.75
1.00	.40	.60	.95	-	42	1.20
1.50	.55	.75	1.25	-	47	1.80
2.00	1.00	1.20	1.75	-	48	2.45
2.50	.70	1.20	2.00	-	52	4.00
3.00	.95	1.35	2.20	-	52	4.00
3.50	1.10	1.55	2.25	3.50	60	4.50
4.00	1.25	1.50	2.30	3.45	65	5.00
4.50	1.55	1.70	2.35	3.80	68	5.70
5.00	1.75	1.95	2.70	4.65	62	5.85
5.50	1.70	2.00	2.80	5.50	60	6.70
6.00	1.60	1.85	2.50	3.75	72	8.00
6.50	1.75	2.05	2.85	3.90	73	8.90
7.00	1.55	1.90	3.15	4.65	59	8.95
7.50	2.10	2.50	3.20	4.30	55	9.50
8.00	1.90	2.10	3.05	4.30	58	10.25
9.00	2.10	2.40	3.60	5.20	70	12.00
9.50	1.90	2.30	3.67	5.35	68	12.50
10.50	2.25	2.65	4.10	5.80	70	13.50
12.00	2.55	3.00	4.80	7.20	69	15.00
13.50	3.00	3.45	6.25	9.95	68	18.15
15.50	3.40	3.60	5.15	7.75	70	19.80
17.50	3.90	4.25	6.65	9.85	71	23.50
19.50	3.80	4.30	6.70	10.45	73	27.50
21.50	4.65	5.15	7.65	11.85	75	30.30
24.00	5.40	6.25	8.40	14.95	72	33.50
28.00	5.75	7.10	13.00	23.05	67	46.60
30.00	5.50	7.35	13.40	23.00	70	50.50
35.00	7.05	10.10	19.35	31.75	65	52.00
40.00	9.45	14.50	24.00	39.95	63	54.50
45.00	14.50	19.35	31.30	45.00	60	59.50
50.00	17.80	24.20	38.70	-	-	63.00



C-169 / C-170 WA

Industrial Burner Nozzles for atomization



INDUSTRIAL OIL NOZZLE

The C-169-WA and C-170-WA nozzles are widely used on Industrial Burners using up to 21 psi air pressure for atomization, and oil pressure at least 2 psi higher (depending on oil flow rate desired). Excellent firing results can be obtained when these nozzles are used in combination with high velocity combustion air through properly designed Air Mixing Equipment to give the flame a rapid whirling motion.

Air and oil are fed into a common swirl chamber through separate openings to properly proportion the two, resulting in the oil being discharged in exceptionally fine spray ready for burning. Flow ratings in the table are on No. 2 fuel oil, but heavy oils can be handled satisfactorily provided they are preheated to bring the viscosity down to about 100 SSU. Flow rates shown are approximate maximums, and turndown ratios between 3 and 4 to 1 can be obtained by reducing air pressure to as low as 5 psi, keeping oil pressure always at least 2 psi higher than the air.

Best atomization is obtained with oil pressure 8 to 10 psi over the air pressure. Some Manufacturers operate at 15 psi constant air pressure and vary only the oil pressure for different flow rates and others modulate both air and oil pressures for maximum turndown. Air requirements depend on air and oil pressures used, as any particular flow rate can be produced by an infinite number of different air-oil pressure combinations. Curve charts showing oil flow rates and air consumption at different air and oil pressures are available upon request for each size nozzle.

DIMENSIONS

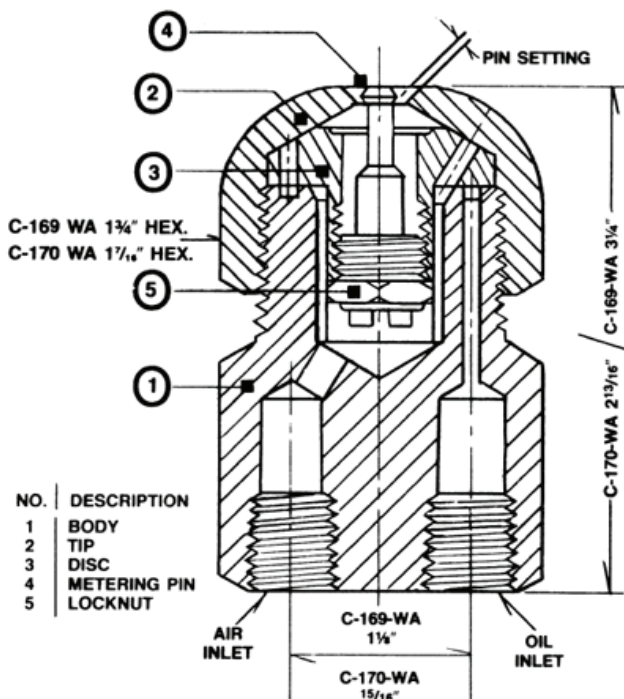

C-169-WA and C-170-WA nozzles are made of cold rolled steel and can be supplied with spray angles from 50° to 100° in 10° steps. 80° spray angle is considered the standard and will be furnished unless ordered otherwise. Weight: C-170-WA 1.2 lbs.; C-169-WA 2.0 lbs. Ordering: Specify quantity, figure number, capacity size and spray angle. Note: Oil pressure must be at least 2 PSI higher than air pressure. Refer to burner manufacturer's instructions. Preheating is recommended for higher viscosity oils.

MATERIAL

Cold rolled steel

PIPE CONNECTION

1 1/2" NPT

SPRAY ANGLES

80° standard

50° - 100°

C-169 / C-170 WA

Industrial Burner Nozzles for atomization

INDUSTRIAL OIL NOZZLE

CAPACITIES

Minimum Capacity: Gallons Per Hour				
FIG No	RATED GPH	NPT CONNECTIONS		PIN SETTING
		AIR	OIL	
C-170-WA	17	1/8"	1/8"	.020"
	30	1/8"	1/8"	.030"
C-169-WA	30	1/4"	1/4"	.030"
	40	1/4"	1/4"	.030"
	50	1/4"	1/4"	.040"
	60	1/4"	1/4"	.040"
	80	1/4"	1/4"	.040"
	100	1/4"	1/4"	.050"
	125	3/8	1/4"	.062"
	150	3/8"	1/4"	.062"
	200	3/8"	3/8"	.062"
	250	3/8"	3/8"	.062"



C-202

Air Operated Nozzle



INDUSTRIAL OIL NOZZLE

Monarch offers a superior line of nozzles including the C-202 Air Operated Nozzle. This series is widely used on industrial burners using up to 50 psi air pressure for atomization.

The C-202 nozzle is recommended for large capacity industrial applications such as airports, manufacturing facilities, universities and military applications. For excellent firing results, use the C-202 in combination with high velocity combustion air. C-202 nozzles are made of cold rolled steel and are precisely machined to combine air and oil into a common swirl chamber through separate openings to properly proportion the two. This results in the oil being discharged in exceptionally fine spray ready for burning. Flow ratings in the table are based on No. 2 fuel oil, but heavy oils can be handled satisfactorily provided they are preheated to bring the viscosity down to about 150 SSU.

Flow rates shown are determined by air and oil pressured and turndown ratios between 3 and 4 to 1 can be obtained by reducing air pressure to as low as 5 psi, keeping oil pressure always at least 2 psi higher than the air. Best atomization is obtained by regulating the air pressure. Some manufacturers operate at 15 psi constant air pressure and vary only the oil pressure for different flow rates and others modulate both air and oil pressures for maximum turn-down. Minimum air requirement depends on oil pressures used, as any particular flow rate can be produced by an infinite number of different air-oil pressure combinations. Curve charts showing oil flow rates and air consumption at different air and oil pressures are available upon request for each size nozzle.

The C-202 nozzles comes with angles of 60° or 80° spray angle but other specifications are available for custom.

MATERIAL

Cold rolled steel

PIPE CONNECTION

1/8" to 3/8" depending on size

SPRAY ANGLES

60° or 80°

other specifications are available on enquiry

CAPACITIES & DIMENSIONS

Minimum Capacity: Gallons Per Hour			
150 SSU	Capacity GPH	Air Pressure PSIG	Oil Pressure PSIG
A-50	33.0	14	10
	40.0	10	8
B-50	35.0	14	10
	42.0	10	8
C-50	67.0	14	10
	72.0	10	8
D-50	5.0	10	8
	20.0	10	10
E-50	11.0	14	10
	16.0	10	8
	29.0	10	10
F-50	70.0	14	10
	75.0	10	8
	100.0	10	10
150.0	50.0	52.5	65.0



C-206

Air Operated Nozzle



INDUSTRIAL OIL NOZZLE

Monarch offers a superior line of nozzles including the C-206 Air Operated Nozzles. This series is widely used on industrial burners using 30 psi for optimal atomization.

For excellent firing results use the C-206 in combination with high velocity combustion air. C-206 nozzles are made of cold rolled steel and are precisely machined to combine air and oil into a common swirl chamber through separate openings to properly proportion the two. This results in the oil being discharged in exceptionally fine spray ready for burning. Flow ratings in the table are based on No. 2 fuel oil, but heavy oils can be handled satisfactorily provided they are preheated to bring the viscosity down to about 100 SSU.

Flow rates shown are determined by air and oil pressures and turndown ratios between 3 and 4 to 1 can be obtained by reducing air pressure to as low as 5 psi, keeping oil pressure always at least 2 psi higher than the air. Best atomization is obtained by regulating the air pressure. Some manufacturers operate at 15 psi constant air pressure and vary only the oil pressure for different flow rates and others modulate both air and oil pressures for maximum turn-down. Minimum air requirement depends on oil pressures used, as any particular flow rate can be produced by an infinite number of different air-oil pressure combinations. Curve charts showing oil flow rates and air consumption at different air and oil pressures are available upon request for each size nozzle.

The C-206 nozzles come standard as a 60° spray angle but other specifications are available for custom requests. ORDERING: Specify quantity and figure number. Note: Oil pressure must be at least 2 PSI higher than air pressure. Refer to burner manufacturer's instructions.

MATERIAL

Cold rolled steel

PIPE CONNECTION

1/8" to 3/8" depending on size

SPRAY ANGLES

60°

CAPACITIES & DIMENSIONS

Minimum Capacity: Gallons Per Hour				
*TIP No.	*Disc No.	Capacity	Air Pressure PSIG	Oil Pressure PSIG
A-1	A-2	15.0	15 lbs.	14 lbs.
A-3	A-4	20.0	15 lbs.	12.5 lbs.
A-5	A-6	30.0	15 lbs.	12.15 lbs.
B-1	B-2	50.0	15 lbs.	12 lbs.
B-3	B-4	98.0	15 lbs.	12 lbs.
B-1	B-4	135.0	12 lbs.	12 lbs.
C-1	C-2	145.0	8 lbs.	8 lbs.

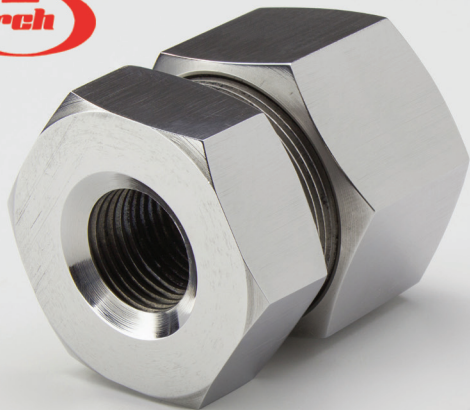

D-41

Atomizing Nozzle for a wide range of applications

INDUSTRIAL OIL NOZZLE

The Fig. D-41 direct pressure operated Industrial Oil Nozzle will spray oils having an operating viscosity as high as 100 SSU with liquid pressure of 200-250 psi., depending upon the capacity size—the smaller the capacity, the higher the pressure required. Will handle Bunker "C" oil if heated to about 180° to 200° with 200 psi pressure.

Tips and Discs are case hardened and lapped for proper seating and should not be transposed. Each matched Tip and Disc combination is identified by a letter stamped on each part so the customer can always determine mating parts.

Nozzles are always rated and stamped for capacity on No. 2 fuel oil at 100 psi. If order so specifies (and at a nominal extra charge), nozzles can be tested for spray angle and spray quality on either No. 2 or 100 SSU operating viscosity oil at pressures of either 200, 250 or 300 psi.* Flow rates in the table are based on No. 2 fuel oil of 34 SSU viscosity at 100°F. On 100 SSU viscosity oil, flow rates will increase about 10% over No. 2 oil rating.

*When so tested, the spray angle test pressure is stamped on the nozzles. If tested on 100 SSU oil, the nozzles are stamped "D-41-HO".

ORDERING:

Specify Quantity, Capacity Size, Pipe Size Connection (1/2" or 3/4" NPT), Spray Angle desired (Can be furnished in 10° steps from minimums shown in chart to 100° maximum), Operating Pressure available and whether to be tested on No. 2 oil or 100 SSU oil. If not otherwise specified, nozzles will be tested only on No. 2 oil at 100 psi.

MATERIAL

Please ask us for more information.

PIPE CONNECTION

1/2 " or 3/4 " NPT

SPRAY ANGLES

The spray patterns (i.e. hollow cone or solid cone) described below refer to the tests carried out with a 60° angle at a 75 mm distance from the nozzle orifice. In nozzles of a 60° spray angle or less, and for low flows in particular, the empty section of a hollow cone becomes smaller. The difference between hollow cone and solid cone practically disappears.

D-41

Atomizing Nozzle for a wide range of applications

DIMENSIONS & CAPACITIES

Minimum Capacity: Gallons Per Hour				
Rated GPH at 100 PSI	Operating Pressure			Min. Angle
	150	200	250	
12.0	14.5	17.0	19.0	50°
14.0	18.0	19.8	22.1	50°
17.0	20.5	24.0	26.8	50°
21.0	25.5	29.5	33.2	50°
24.5	30.0	34.5	38.5	50°
27.0	33.0	38.0	42.7	50°
30.0	36.5	42.5	48.5	50°
34.5	42.0	48.5	54.5	50°
40.0	49.0	56.6	63.5	50°
42.0	51.5	59.5	66.5	50°
45.0	55.0	63.5	71.5	50°
50.0	61.0	70.5	79.5	50°
55.0	67.0	78.0	87.0	50°
60.0	73.0	85.0	95.0	50°
65.0	80.0	92.5	103.0	50°
70.0	86.0	99.0	110.0	50°
78.0	95.5	110.0	123.0	50°
88.0	107.0	125.0	139.0	60°
95.0	116.0	135.0	150.0	60°
100.0	122.0	141.0	158.0	60°
107.0	131.0	151.0	169.0	60°
128.0	157.0	181.0	202.0	60°
140.0	172.0	196.0	222.0	70°
150.0	184.0	213.0	238.0	70°
163.0	200.0	231.0	257.0	70°
170.0	209.0	240.0	268.0	70°
175.0	215.0	248.0	276.0	70°
188.0	230.0	266.0	298.0	70°
200.0	245.0	284.0	317.0	70°
225.0	275.0	318.0	355.0	70°
237.0	290.0	333.0	373.0	80°
241.0	296.0	340.0	381.0	80°
250.0	305.0	353.0	395.0	80°
260.0	319.0	368.0	410.0	80°
280.0	342.0	395.0	455.0	80°
300.0	370.0	425.0	485.0	80°
313.0	389.0	443.0	505.0	80°
327.0	411.0	462.0	535.0	80°
360.0	436.0	510.0	565.0	80°
400.0	480.0	565.0	625.0	80°

INDUSTRIAL OIL NOZZLE



E-180

Variable flow nozzle

INDUSTRIAL OIL NOZZLE

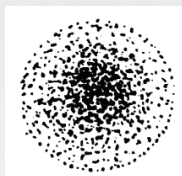
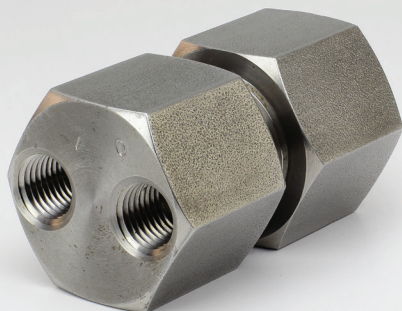

The E-180-H Nozzles is a large Industrial Nozzles in which the orifice flow is varied by by-passing or "bleeding" liquid from the Nozzle swirl chamber while the line pressure to the Nozzle remains constant. Capacity is varied between maximum and minimum by controlling the by-pass line pressure, and excellent firing results are obtained with turn-down ratios of 3 to 4 to 1.

The capacity and spray angle ratings are based on operating at 300 PSIG line pressure on 100 SSU operating viscosity oil with the by-pass line closed. Spray angles available are 40°, 50°, 60° and 80° and it should be noted that spray angles increase from 5° to 10° when the by-pass line is wide open. These Nozzles may be used on No. 2 fuel oil, but capacities and spray angles will be approximately 10% less than on 100 SSU oil. Oil of 100 SSU operating viscosity is typically obtained by preheating U.S. No.6 fuel oil to 175°F to 265°F with a norm of about 240°F.

Accompanying charts show flow through the orifice when the bypass pressures are at various points from open to closed. Note that the total flow to the Nozzle (when the by-pass line is wide open) can be almost 50% greater than the nominal capacity of the Nozzle and this must be taken into account when sizing pumps. Pressure-flow curves can be supplied for any specific capacity size, on request.

Nozzles are made of cold rolled steel, with tips and discs case hardened and individually lapped together as mated sets. Complete E-180-H Nozzles have a net weight of approximately 18-1/2 ounces. The tip and disc set have a net weight of approximately 2 ounces.

MATERIAL

Please ask us for further information.

PIPE CONNECTION

Please ask us for further information.

SPRAY ANGLES

60° or 80°

Other specifications are available on enquiry

CAPACITIES & DIMENSIONS

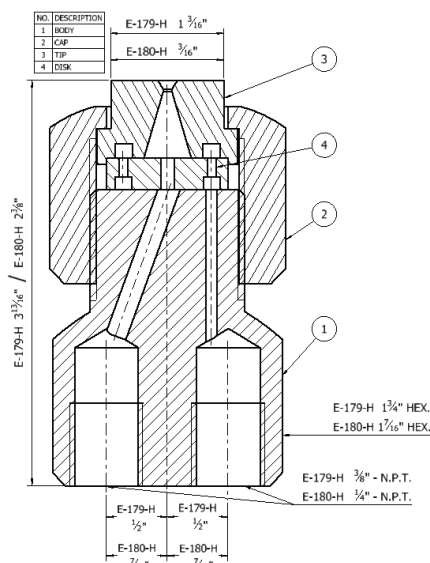

E-180

Variable flow nozzle

Minimum Capacity: Gallons Per Hour							
Nozzle No.	Function Pressure – By Inch-pound limit						
Nominal Capacity, GPH: BY-PASS CLOSED	By-Pass Pressure - PSIG					BY-PASS PRESSURE - BY-PASS CLOSED	TOTAL** FLOW: GPH TO NOZZLE BY-PASS OPEN
	0	50	100	150	200		
15.0	4.5	5.5	9.0	-	-	140	18.5
20.0	4.5	7.0	14.0	-	-	125	23.5
25.0	5.0	6.0	9.0	16.0	-	175	36.0
30.0	8.0	9.0	12.0	18.0	-	190	38.0
35.0	8.0	8.5	13.0	20.0	35.0	200	49.0
40.0	8.0	9.0	13.0	20.0	34.0	210	57.0
45.0	9.0	11.0	14.0	20.5	35.0	210	61.5
50.0	12.0	13.0	18.0	27.0	44.0	210	73.0
55.0	15.0	16.0	20.0	29.0	48.0	210	84.0
60.0	14.0	14.5	20.0	38.0	-	170	78.0
65.0	13.5	16.0	22.0	38.5	-	175	84.0
70.0	26.0	27.5	34.0	45.0	64.0	210	102.0
75.0	19.0	20.0	27.0	42.0	67.0	210	105.0
80.0	21.0	22.5	33.0	51.0	80.0	200	105.0
85.0	21.0	22.5	33.0	49.0	80.0	205	111.0
90.0	25.0	25.0	35.0	54.0	-	190	116.5
100.0	30.0	31.0	36.0	53.0	83.0	215	146.0
120.0	27.0	30.0	40.0	62.5	103.0	210	165.0
130.0	36.0	40.0	55.0	73.0	106.0	220	187.0
140.0	25.0	27.5	38.0	62.0	105.0	220	192.5
150.0	50.0	52.5	65.0	94.0	130.0	225	217.5



B-25 AAMA Kit

Large Capacity Nozzle



AAMA KIT NOZZLE

The B-25 Nozzles are of two piece construction with large tangential metering slots in the internal Disc to give a nonrestricted flow with a uniform "Solid" distribution. For special applications, a hollow cone spray can be produced from this same design. These Nozzles with high flow rates and coarser sprays are used in gas scrubbing, adsorption towers, brine spraying, and chemical and industrial processing.

MATERIAL

Brass is standard with 1/2" NPT. Also available in any machinable material on request.

PIPE CONNECTION

3/8", 1/2", 3/4",
1", 1 1/2", 2" NPT

SPRAY ANGLES

80° at 40 PSI

AAMA kit available

Water test kit includes:

- (1) B-25 6.030 W/1/2" FNPT
- (1) 3/4" Globe valve
- (1) 3/4" Garden hose adaptor
- (1) 0-60 PSI Pressure gauge
- (1) Case Fully assembled and ready to use!

Please ask for further information.



B-25 AAMA Kit

Large Capacity Nozzle

AAMA KIT NOZZLE

CAPACITIES & DIMENSIONS

B-25 Capacities: Gallons Per Minute											
Pipe Size	Nozzle No.*	Operating Pressure – Lbs. per Square Inch						Dimensions and Weights			
		5	10	20	40	80	100		Width	Hexagon	Weight (Oz.)
3/8"	2.5	.9	1.2	1.8	2.5	3.5	3.9	1 5/8"	7/8"	7/8	3 1/2
	3.0	1.1	1.5	2.1	3.0	4.2	4.7				
	3.5	1.2	1.7	2.5	3.5	4.9	5.5				
	4.0	1.4	2.0	2.8	4.0	5.7	6.3				
1/2"	4.5	1.6	2.2	3.2	4.5	6.3	7.1	2"	1 1/8"	1 1/8	7 1/2
	5.0	1.8	2.5	3.5	5.0	7.1	7.9				
	6.0	2.1	3.0	4.2	6.0	8.5	9.5				
1/2" or 3/4"	7.0	2.5	3.5	4.9	7.0	9.9	11.1				
	8.0	2.8	4.0	5.6	8.0	11.3	12.6				
3/4"	9.0	3.2	4.5	6.4	9.0	12.7	14.2	2 1/4"	1 3/8"	1 3/8	12
	10.0	3.5	5.0	7.1	10.0	14.1	15.8				
	12.0	4.2	6.0	8.5	12.0	17.0	19.0				
	15.0	5.3	7.5	10.6	15.0	21.2	23.7				
*"Nozzle No." is capacity in GPM @ 40 PSI water pressure 1" and larger are made from castings. 3/4" and smaller are made from bar stock.											
1"	17/64" ori.	4.2	6.0	8.4				2 7/16"	1 7/16"	1 5/8	12



629 / 631

Swirl Chamber Nozzle

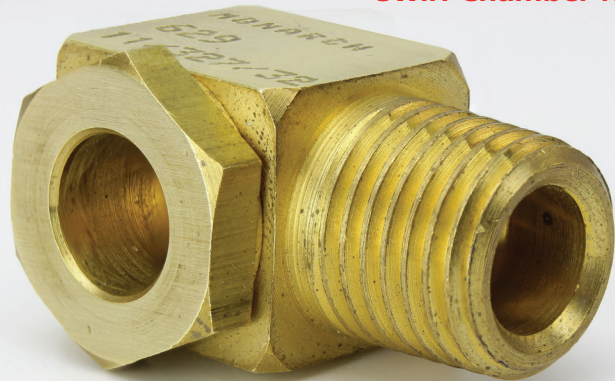

WATER NOZZLE

Because inside the nozzles 629 and 631 are no spacers, they are virtually nonclogging. Each foreign body for which the large tangential inflow permeable, is simply blown through the nozzle opening. The shape of the vortex chamber, both at End is conical, produces a uniform Hollow cone distribution. The atomization at a higher pressure and a larger spray angle is finer.

Typical applications include air-wash systems, ventilators, cooling towers, sparkling resolution, smoke and dust removal, gas cooling, waxing, degreasing and general industrial processing and agricultural applications.

MATERIAL

Brass and 303 stainless steel as standard.
Also available in hard rubber or any other material processed.

PIPE CONNECTION

629 (male) 1/8", 1/4" NPT
631 (male) 1/8", 1/4" NPT

SPRAY ANGLES

Standard: 80° at 40 PSI. jet with an opening of up to 1/8" available in 120°.

629 Dimensions						
Pipe Size	A	B	C	D	E	Weight (oz.)
1/8	9/10	9/10	5/8	1/2	1/2	1
1/4	11/10	11/10	13/16	5/8	5/6	2
3/8	3/4	3/4	15/16	3/4	3/4	3 1/4
631 Dimensions						
Pipe Size	A	B	C	D		Weight (oz.)
1/8	1 1/8	5/8	1/2	1/2		1
1/4	1 5/16	13/16	5/8	5/8		2
3/8	1 1/8	15/16	3/4	3/4		3 1/4
1/2	1 15/16	1 1/4	7/8	1		4 3/4
3/4	2 1/2	1 9/16	1 1/4	1 1/4		16
1	3	1 13/16	1 1/2	1 1/2		23

CAPACITIES & DIMENSIONS

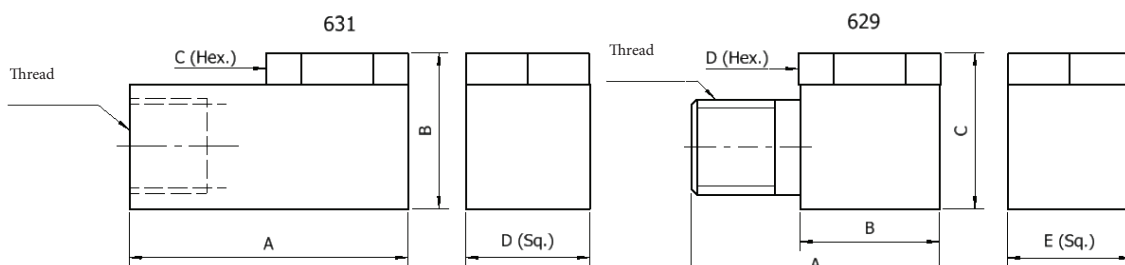

629 / 631

Swirl Chamber Nozzle

WATER NOZZLE

Capacities: Gallons Per Hour										
Pipe Size	Orifice	Lead	Operating Pressure: Lbs. Per Square Inch							
			5	10	20	30	40	60	80	100
1/8" or 1/4"	69	69	—	—	2.7	3.3	3.8	4.7	5.4	6.0
	61	61	—	—	4.2	5.1	5.9	7.2	8.3	9.2
	61	53	2.7	3.7	5.3	6.5	7.5	9.2	10.5	11.8
	53	53	4.0	5.7	8.2	10.0	11.5	14.1	16.3	18.2
	49	49	5.6	7.9	11.1	13.6	15.7	19.3	22.2	24.8
	3/32	3/32	9.6	13.5	19.2	23.4	27.0	33.0	38.4	42.9
	1/8	3/32	12.2	17.3	24.4	29.9	34.6	42.4	49.0	54.9
	1/8	7/64	14.6	20.6	29.1	35.7	41.0	50.4	58.4	65.1
	1/8	1/8	15.9	22.5	31.9	39.2	45.1	55.2	63.7	71.5
1/4 "	11/64	1/8	21.7	30.6	43.2	53.0	61.1	75.0	86.4	98.0
	3/16	5/32	30.5	43.2	61.1	74.9	86.4	107	122	136
	7/32	3/16	45.1	63.8	90.5	110	128	156	180	202
	13/64	13/64	54.6	77.8	108	134	155	191	217	246
	7/32	7/32	59.8	84.5	120	146	169	207	240	267
	9/32	7/32	88.4	125	177	217	250	306	354	395
	17/64	1/4	102	141	199	244	282	345	399	446
	17/64	17/64	122	173	245	300	346	424	489	547
	9/32	17/64	135	191	270	331	382	468	540	604
	19/64	9/32	143	203	287	352	406	497	574	642
3/8 "	11/32									
	3/16	3/16	35	49	69	85	98	120	138	155
	7/32	7/32	50	71	101	123	142	175	202	225
	1/4	1/4	71	101	142	175	202	246	284	319
	9/32	9/32	98	138	196	240	276	339	392	433
	6/16	9/32	124	176	249	305	352	431	498	557
	21/64	21/64	170	240	339	416	480	588	679	759
	11/32	21/64	180	255	361	442	510	625	721	806
	3/8	11/32	222	314	444	544	628	769	888	993
	13/32	11/32	254	360	509	624	720	882	1018	1138
1/2 "	7/16	11/32	266	378	535	655	756	926	1069	1195
	15/32	11/32	300	425	610	736	850	1041	1202	1344
	3/8	5/16	145	206	290	356	411	495	580	651
	3/8	3/8	182	258	365	448	516	634	730	816
	13/32	3/8	207	293	413	507	586	718	826	926
	7/16	3/8	226	321	453	555	641	787	905	1015
	15/32	3/8	245	346	496	600	691	848	975	1094
3/4 "	1/2	3/8	266	375	530	651	750	920	1062	1185
	7/16	7/16	235	332	471	576	665	815	941	1048
	9/16	7/16	321	455	644	790	910	1120	1285	1450
	9/16	1/2	350	495	700	858	989	1215	1395	1595
1 "	5/8	1/2	407	576	830	1018	1183	1440	1660	1860
	9/16	9/16	372	526	744	914	1051	1290	1490	1665
	5/8	9/16	422	597	845	1115	1193	1470	1690	1890
	5/8	5/8	510	720	1018	1250	1440	1760	2035	2280



F-80-W

Swirl Chamber Nozzle

WATER NOZZLE



The F-80 Hollow Cone Nozzles produce the finest possible breakup with direct pressure operation. No air or steam is required as the atomizing medium. While higher pressures produce finer droplet sizes, these Nozzles will operate satisfactory on water at pressures of 40 PSI or more. These nozzles are equipped with a 9/16" – 24" machine thread for mounting in either single or multiple adaptors.

MATERIAL

Brass and 416 Stainless Steel with 120 mesh Monel screen strainers. Also available in 303, 304 and 316*

PIPE CONNECTION

9/16" NPT

SPRAY ANGLES

30°, 45°, 60°, 80°, 90°. Sizes #3.0 to #9.5 available in 100°. All ratings are at 40 PSI. Capacities: 0.5 – 100.00 GPH on water.

CAPACITIES & DIMENSIONS

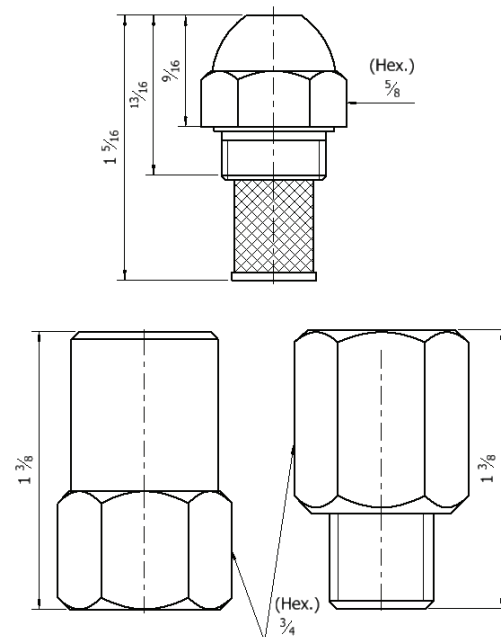



H-261(-CJ)

DIRECT PRESSURE ATOMIZING NOZZLE



WATER NOZZLE

The **H-261** direct pressure operated Nozzle produces a very fine hollow cone spray similar to the F-80 Nozzle. However, it has a 1/4" male NPT thread, so no adaptor is needed, and it can be connected directly to a 1/4" Tee. Material: All Brass, with 120 mesh Monel Strainer. Primary use is at snow cannons or spray racks.

The **H-261-CJ** is the same general construction as the H-261 Nozzle. This version includes a "Center Jet" through the middle of the swirler which produces a Solid Cone Spray and somewhat coarser atomization. It has proven extremely successful in commercial dish washers.

MATERIAL

Models completely made of brass

PIPE CONNECTION

1/8" NPT male

SPRAY ANGLES

30°, 45°, 60°, 80°, 90°.

Sizes #3.0 to #9.50 available in 100°.

H-261-CJ: 80°

All ratings are at 40 PSI.

DIMENSIONS

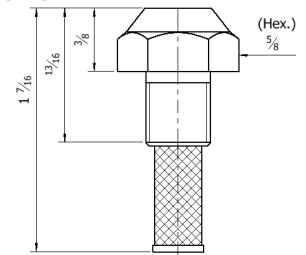

CAPACITIES

H-261 Capacities: Gallons Per Hour							
Nozzle No.	Operating Pressure: Lbs. Per Square Inch						Min. Oper. Pressure (PSI)
	40	60	80	100	200	100	
.75	—	.40	.50	.60	.65	.90	40
1.00	—	.45	.60	.65	.75	1.05	40
1.25	—	.50	.65	.75	.85	1.20	40
1.35	—	.55	.70	.80	.90	1.25	40
1.65	—	.75	.90	1.05	1.20	1.70	40
2.00	—	.95	1.15	1.30	1.50	2.10	35
2.50	—	1.15	1.40	1.60	1.80	2.55	30
3.00	1.00	1.25	1.55	1.80	2.00	2.85	25
3.50	1.30	1.65	2.00	2.30	2.60	3.65	25
4.00	1.50	1.90	2.35	2.70	3.00	4.25	20
4.50	1.90	2.40	2.95	3.40	3.80	5.40	20
5.00	2.20	2.80	3.40	3.95	4.40	6.20	20
5.50	2.40	3.05	3.70	4.30	4.80	6.80	15
6.00	2.60	3.30	4.05	4.65	5.30	7.50	15
6.50	2.80	3.55	4.35	5.00	5.60	7.90	15
7.00	3.00	3.80	4.65	5.35	6.00	8.50	15
7.50	3.20	4.05	4.95	5.75	6.40	9.05	10
8.50	3.50	4.45	5.40	6.25	7.00	9.90	10
9.50	3.80	4.80	5.90	6.80	7.60	10.75	10
10.50	4.10	5.20	6.35	7.35	8.20	11.60	10
12.00	4.80	6.05	7.45	8.60	9.60	13.60	10
13.50	5.45	6.90	8.45	9.75	10.90	15.40	10
15.50	6.35	8.00	9.85	11.40	12.70	18.00	10
17.50	7.20	9.10	11.20	12.90	14.40	20.40	10
19.50	8.80	11.10	13.60	15.70	17.60	24.90	10
21.50	10.50	13.30	16.30	18.80	21.00	29.70	10
24.00	11.80	14.90	18.30	21.20	23.60	33.30	10
30.00	15.00	19.00	23.20	26.90	30.00	42.40	10

H-261-CJ Capacities: Gallons Per Hour						
Nozzle No.*	Operating Pressure: Lbs. Per Square Inch					
	40	60	80	100	200	
25	40	60	80	100	200	
5.5	2.7	3.5	4.2	4.9	5.5	
7.0	3.5	4.4	5.4	6.2	7.0	
12.5	6.2	7.9	9.7	11.2	12.5	
14.5	7.2	9.3	11.2	13.0	14.5	
20.0	10.0	12.6	15.4	17.9	20.0	
22.5	11.2	14.2	17.4	20.2	22.5	
30.0	15.0	19.0	23.2	26.8	30.0	
37.0	18.5	23.4	28.6	33.1	37.0	
46.5	23.2	29.4	35.9	41.6	46.5	
60.0	30.0	38.0	46.4	53.6	60.0	
72.0	36.0	45.5	55.6	64.5	72.0	
84.0	42.0	53.1	65.0	75.2	84.0	
120	60.0	76.0	93.0	107	120	
133	66.5	84.1	103	119	133	
163	81.5	103	126	146	163	
180	90.0	114	139	161	180	
200	100	126	155	179	200	
8.50	3.50	4.45	5.40	6.25	7.00	
9.50	3.80	4.80	5.90	6.80	7.60	
10.50	4.10	5.20	6.35	7.35	8.20	
12.00	4.80	6.05	7.45	8.60	9.60	
13.50	5.45	6.90	8.45	9.75	10.90	
15.50	6.35	8.00	9.85	11.40	12.70	
17.50	7.20	9.10	11.20	12.90	14.40	
19.50	8.80	11.10	13.60	15.70	17.60	
21.50	10.50	13.30	16.30	18.80	21.00	
24.00	11.80	14.90	18.30	21.20	23.60	
30.00	15.00	19.00	23.20	26.90	30.00	



H-530

Nonclog Nozzle

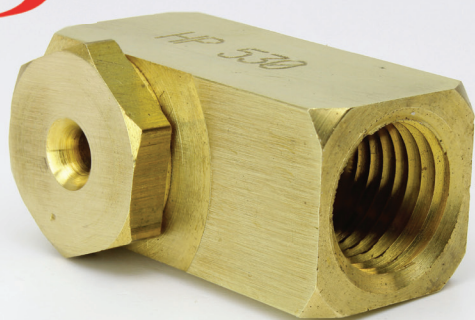

WATER NOZZLE

The H-530 is a simple Nozzle which is a variation of the nonclog principle. Nozzle consists of two parts, the Body which contains the inlet pipe connection and the orifice; and a Cap which forms the bottom of the Swirl Chamber. The solid cone spray is uniformly distributed over the entire area of coverage. Typically used where a right angle connection is required for gas scrubbing, rinsing, washing, quenching and dust control.

MATERIAL

Brass. Available as a special in any machinable material.

PIPE CONNECTION

1/4" NPT.

SPRAY ANGLES

80° at 40 PSI.

DIMENSIONS

CAPACITIES

Minimum Capacity: Gallons Per Minute								
Pipe Size	Nozzle No.*	Operating Pressure: Lbs. Per Square Inch						
		10	20	30	40	60	80	100
1/4 "	62	0.26	0.36	0.44	0.51	0.62	0.72	0.81
	78	0.38	0.58	0.70	0.83	1.0	1.2	1.3
	93	0.60	0.85	1.0	1.2	1.5	1.7	1.9
	104	0.75	1.0	1.3	1.5	1.8	2.1	2.4
	109	0.80	1.1	1.4	1.6	2.0	2.3	2.5
	140	1.0	1.5	1.8	2.1	2.6	3.0	3.3
	156	1.3	1.8	2.2	2.5	3.1	3.5	4.0
	171	1.4	2.0	2.5	2.9	3.6	4.1	4.6
	187	1.5	2.1	2.6	3.0	3.7	4.2	4.7
3/8 "	234	2.5	3.5	4.3	5.0	6.1	7.1	7.9
	250	3.3	4.7	5.8	6.7	8.2	9.4	10.6
1/2 "	281	4.2	5.9	7.2	8.3	10.2	11.8	13.2
3/4 "	312	5.3	7.5	9.1	10.6	13.0	15.0	16.7
	343	5.7	8.0	9.8	11.3	13.8	16.0	17.8
	375	6.6	9.3	11.4	13.2	16.2	18.6	20.8
	406	7.6	10.7	13.1	15.1	18.5	21.3	23.8

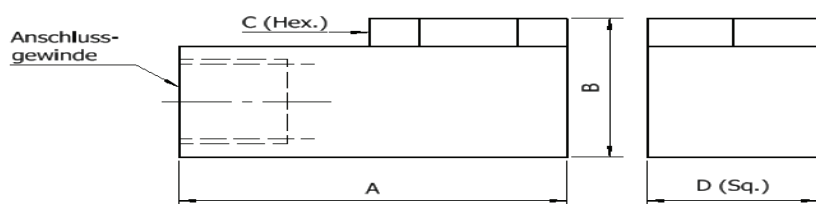

* „Nozzle No.“ is orifice diameter in thousandths of an inch



H-535

Atomizing Nozzle for a wide range of applications

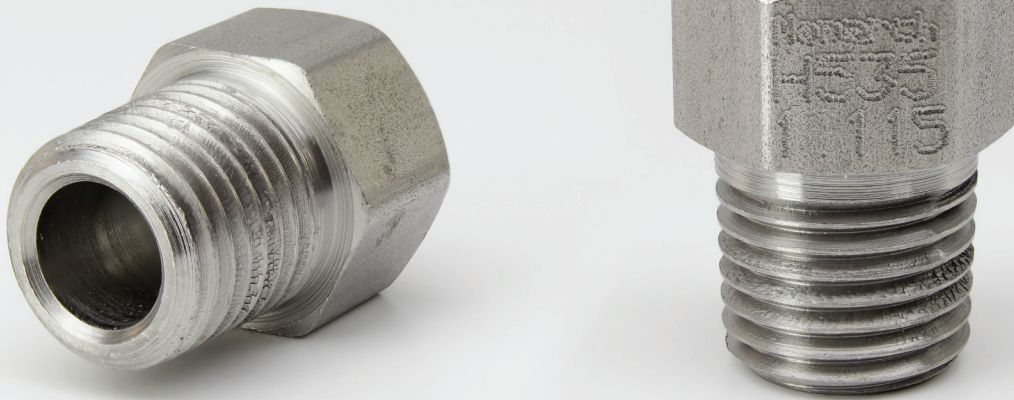

WATER NOZZLE

The H-535 is a simple, one-piece construction. The „V” notch milling and oval orifice produce a very thin, high velocity cutting sheet found to be ideal for car washes, commercial dish washers and other applications where spray velocity is important.

MATERIAL

Brass, 303 Stainless Steel. Other materials to order

PIPE CONNECTION

1/8" & 1/4" NPT.

SPRAY ANGLES

30° to 90° in 10° steps at 40 PSI.

DIMENSIONS

Pipe Size	Dimensions			Weight (oz.)
	A	B	C	
1/8	5/8	3/16	7/16	1/2
1/4	15/16	7/16	5/8	1

CAPACITIES

Minimum Capacity: Gallons Per Minute							
Nozzle No.*	Operating Pressure: Lbs. Per Square Inch						
	10	20	30	40	60	80	100
.20		.14	.17	.20	.25	.28	.32
.35		.24	.30	.35	.43	.49	.55
.40		.28	.34	.40	.49	.56	.63
.44		.31	.38	.44	.54	.62	.70
.50		.35	.43	.50	.62	.70	.79
.60	.30	.42	.52	.60	.73	.85	.95
.75	.37	.53	.65	.75	.93	1.1	1.2
.90	.45	.64	.78	.90	1.1	1.3	1.4
1.0	.50	.71	.86	1.0	1.2	1.4	1.6
1.3	.65	.92	1.1	1.3	1.6	1.8	2.1
1.5	.75	1.1	1.3	1.5	1.8	2.1	2.4
2.0	1.0	1.4	1.7	2.0	2.5	2.8	3.2
3.0	1.5	2.1	2.6	3.0	3.7	4.2	4.7
4.0	2.0	2.8	3.5	4.0	4.9	5.7	6.3

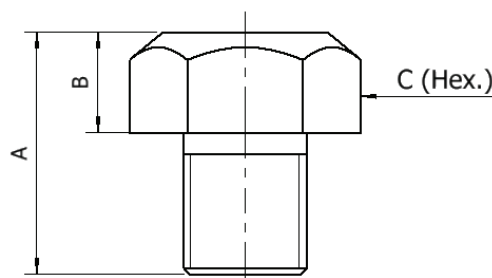



H-545

Atomizing Nozzle for a wide range of applications



WATER NOZZLE

The H-545 is our basic flat spray construction, with a „U“ notch milling and rectangular orifice. A “fat” sheet is produced that is useful for rinsing and washing. Car washes and parts washers commonly utilize these Nozzles.

MATERIAL

Brass and 303 Stainless Steel.
Other materials to order.

PIPE CONNECTION

1/8" to 3/4" NPT male

SPRAY ANGLES

50°, 60°, 70° or 80° at 40 PSI

DIMENSIONS

Dimensions				
Pipe Size	Dimensions			Weight (oz.)
	A	B	C	
1/8"	5/8"	3/16"	7/16"	1/2"
1/4"	15/16"	7/16"	5/8"	1"
3/8"	1"	7/16"	3/4"	1 1/2"
1/2"	1 7/32"	17/32"	7/8"	1 3/4"
3/4"	1 3/8"	8/16"	1 1/15"	4 1/2"

CAPACITIES

Minimum Capacity: Gallons Per Minute								
Pipe Size	Nozzle No.	Operating Pressure: Lbs. per Square Inch						
		10	20	30	40	60	80	100
1/8" or 1/4"	1.0	.50	.71	.86	1.0	1.2	1.4	1.6
	1.3	.65	.92	1.1	1.3	1.6	1.8	2.1
	1.5	.75	1.1	1.3	1.5	1.8	2.1	2.4
	2.0	1.0	1.4	1.7	2.0	2.5	2.8	3.2
	3.0	1.5	2.1	2.6	3.0	3.7	4.2	4.7
1/4"	4.0	2.0	2.8	3.5	4.0	4.9	5.7	6.3
	5.0	2.5	3.5	4.3	5.0	6.1	7.1	7.9
	5.5	2.8	3.9	4.8	5.5	6.8	7.8	8.7
	6.0	3.0	4.2	5.2	6.0	7.3	8.5	9.5
1/4" or 3/8"	7.0	3.5	4.9	6.1	7.0	8.6	9.9	11.1
	8.0	4.0	5.7	6.9	8.0	9.8	11.2	12.7
	9.0	4.5	6.4	7.8	9.0	11.1	12.7	14.3
3/8" or 1/2"	10	5.0	7.1	8.6	10.0	12.2	14.1	15.8
	12	6.0	8.5	10.4	12.0	14.7	17.0	19.0
1/2"	15	7.5	10.6	13.0	15.0	18.4	21.2	23.7
	20	10.0	14.1	17.3	20.0	24.5	28.3	31.6
3/4"	30	15.0	21.3	26.0	30.0	37.0	42.5	47.5
	40	20.0	28.4	34.8	40.0	49.0	56.5	63.5

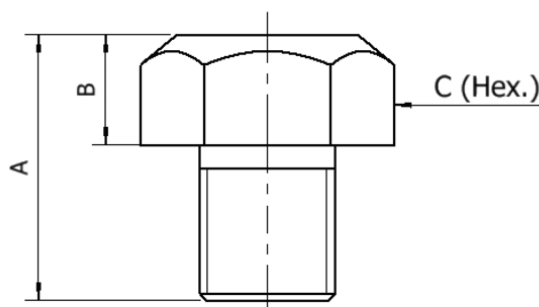



H-601

Air Operated Nozzle



WATER NOZZLE

The H-601 Nozzle is air or steam operated and produces an extremely fine, fog-like atomization. This aspirating Nozzle requires no liquid pressure whatever as the air pressure creates a suction in the liquid inlet which draws the liquid into the Nozzle. If air is readily available you can, therefore, eliminate the expense of a liquid pump. Increasing the lift distance decreases the flow rate. Due to the absence of small internal openings, this Nozzle can produce very low flow rates without risk of clogging.

The H-601 has an unrestricted orifice of $5/64$ " diameter. The H-601-C to H-601-G have, in addition, an internal disc with metering slots to produce extremely low flow rates but the openings are relatively low flow rates but the openings are H-601 Water Nozzles relatively large in comparison to these flow rates.

MATERIAL

Brass or 303 SS on demand. H-601-C to H-601-G Brass only.

CAPACITIES & DIMENSIONS

Please ask us for further information.

PIPE CONNECTION

Air inlet $1/4$ " NPT female, liquid inlet $1/8$ " NPT female

SPRAY ANGLES

45°

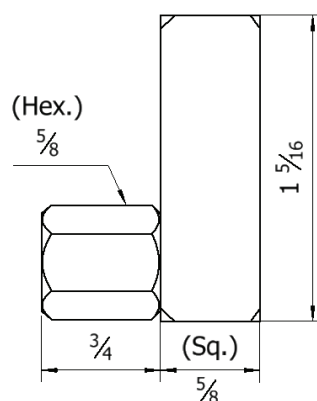



H-837

Solid Jet Nozzle

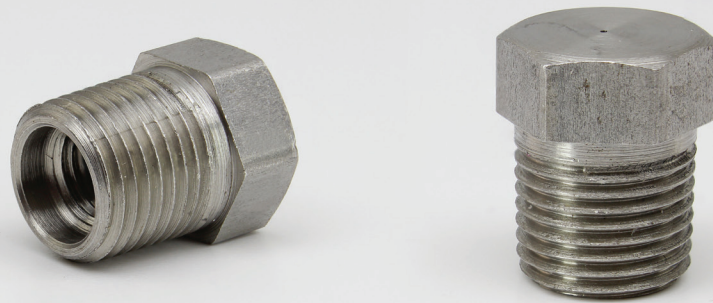

WATER NOZZLE

The H-837 Nozzles produce a solid unbroken stream with a defined jet length before breakup of the liquid occurs. Useful for cleaning and cutting operations. To maximize stream length, mounting close to tees should be avoided as the turbulence produced from "turning the corner" disrupts smooth stream.

MATERIAL

416 SS, 303 SS, 304 SS and 316 SS

CAPACITIES & DIMENSIONS

Please ask us for further information.

PIPE CONNECTION

1/8 " and 1/4 " NPT.

SPRAY ANGLES

0°

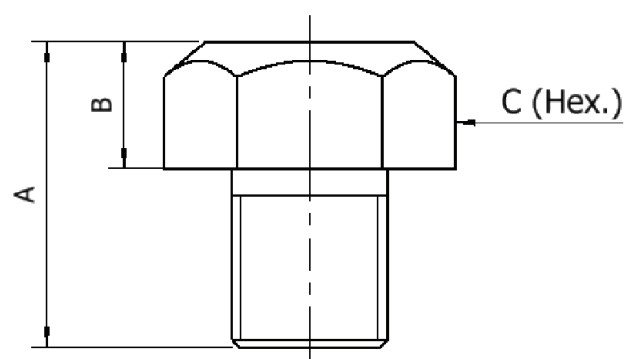



MIDGET

Atomizing Nozzle for a wide range of applications

WATER NOZZLE

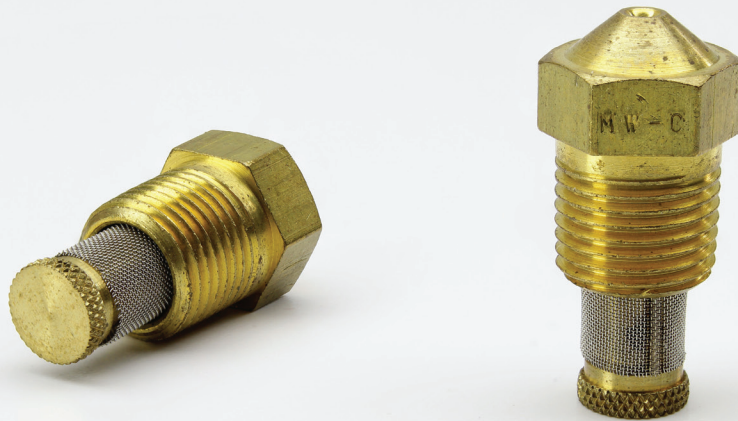

The "M" or "Midget" series is designed to meet the needs of a very small, efficient, inexpensive nozzle. They are particularly effective in applications where the mounting possibility is limited. Both models produce a very fine spray, but the "MW" is a little coarser than the "M". Both come standard with a 80-meshed strainer monel for easy cleaning.

The "M" nozzles are ideal for agricultural and industrial applications that require a similar fog atomizer and with low water consumption. They are often used for humidification in greenhouses and in the mist cooling for pigs and poultry.

The "MW" with a spray angle of 90 ° – 160 ° has many industrial applications where maximum coverage is required in a small space. It is often found in greenhouses for fogging and keeping the young plants wet.

Other sizes on enquiry.

MATERIAL

Models completely made of brass
416 SS would be available per request

PIPE CONNECTION

1/8 "NPT male

SPRAY ANGLES

"M": 80 °

"MW": 90 °, 120 °, 160 °

DIMENSIONS

CAPACITIES

Minimum Capacity: Gallons Per Hour						
Nozzle No.	Function Pressure – By Inch-pound limit					
	25	30	40	60	80	100
M-0.5	–	–	–	–	.45	.50
M-1	–	–	.63	.78	.90	1.00
M-2	1.00	1.10	1.30	1.50	1.80	2.00
M-3	1.50	1.60	1.90	2.30	2.70	3.00
M-5	2.50	2.70	3.20	3.90	4.50	5.00
MW-B	2.30	2.50	2.90	3.50	4.10	4.60
MW-C	3.20	3.50	4.10	4.90	5.70	6.40
MW-D	5.00	5.50	6.30	7.70	8.90	10.00
MW-E	7.20	8.00	9.20	11.20	13.00	14.50

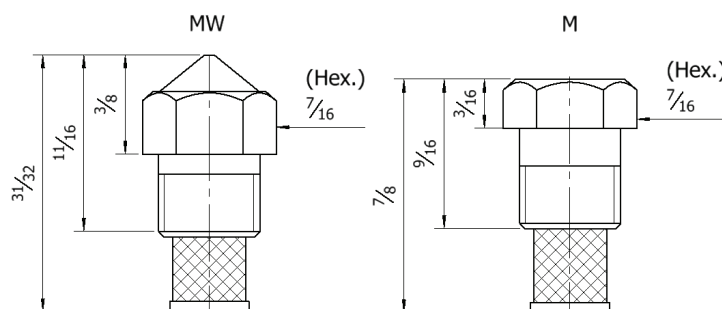



M2P

Plastic Nozzle



WATER NOZZLE

The "M" or "Midget" series is designed to meet the needs of a very small, efficient, inexpensive nozzle. They are particularly effective in applications where the mounting possibility is limited. Both models produce a very fine spray, but the "MW" is a little coarser than the "M". Both come standard with a 80-meshed strainer monel for easy cleaning.

The "M" nozzles are ideal for agricultural and industrial applications that require a similar fog atomizer and with low water consumption. They are often used for humidification in greenhouses and in the mist cooling for pigs and poultry.

Advantages of this nozzles:

- large filter surface
- plug filters for simple cleaning
- nozzle from durable work plastic
- favorable cost-performance ratio

Other sizes on enquiry.

MATERIAL

Durable work plastic

PIPE CONNECTION

1/8 "NPT male

SPRAY ANGLES

"M": 80 °

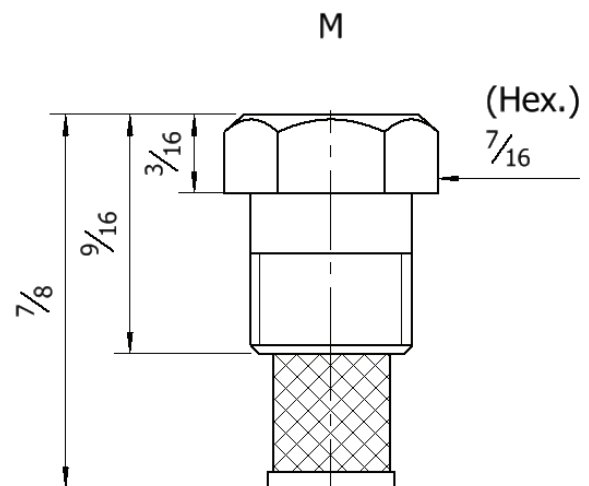

CAPACITIES & DIMENSIONS

Minimum Capacity: Gallons Per Hour						
Nozzle No.	Function Pressure – By Inch-pound limit					
	25	30	40	60	80	100
M-0.5	–	–	–	–	.45	.50
M-1	–	–	.63	.78	.90	1.00
M-2	1.00	1.10	1.30	1.50	1.80	2.00
M-3	1.50	1.60	1.90	2.30	2.70	3.00
M-5	2.50	2.70	3.20	3.90	4.50	5.00



F-94

Nozzle for carbon black production

CARBON BLACK NOZZLE



The F-94 Nozzle is available in a wide range of spray angles for many diverse applications. A unique spirally milled core or "disc" produces a high velocity spinning action that gives a solid cone distribution of medium atomization. The tip has a straight machine thread for use with a male or female adaptor with NPT connections. This Nozzle is particularly successful for dust suppression, industrial washers, coal washing and the production of carbon black.

MATERIAL

Standard in 416 Stainless Steel. Also available in 304 and 316 Stainless Steel

PIPE CONNECTION

1/4 "NPT male

SPRAY ANGLES

15°, 30°, 45°, 60°, 80° at 100 PSI

CAPACITIES & DIMENSIONS

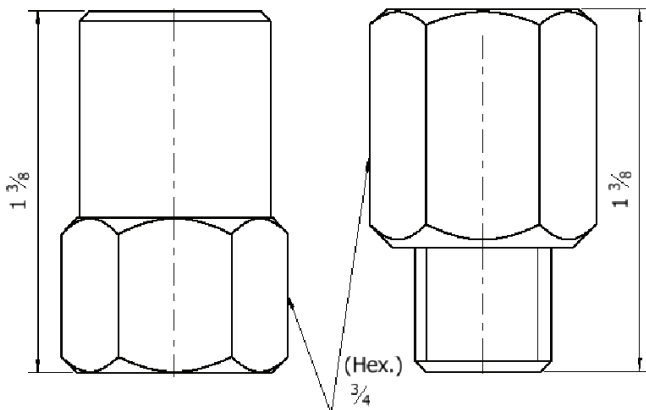
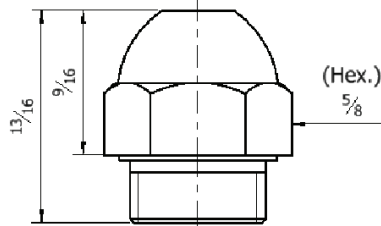

Minimum Capacity: Gallons Per Hour					
Nozzle No.*	Operating Pressure: Lbs. per Square Inch				
	25	40	60	80	100
12.0	6.0	7.6	9.2	10.7	12.0
15.5	7.8	9.8	12.0	13.9	15.5
17.5	8.8	11.1	13.6	15.7	17.5
19.5	9.8	12.3	15.1	17.4	19.5
24.0	12.0	15.2	18.6	21.4	24.0
30.0	15.0	18.9	23.2	26.8	30.0
35.0	17.5	22.1	27.1	31.3	35.0
37.0	18.5	23.4	28.7	33.1	37.0
40.0	20.0	25.2	31.0	35.8	40.0
45.0	22.5	28.4	34.9	40.3	45.0
50.0	25.0	31.5	38.7	44.8	50.0
60.0	30.0	37.9	46.4	53.7	60.0
72.0	36.0	45.5	55.6	64.4	72.0
88.0	44.0	55.6	68.0	78.6	88.0
100	50.0	63.1	77.4	89.5	100
120	60.0	75.8	92.4	107	120
137	68.5	86.6	106	122	137
150	75.0	95.0	116	134	150
175	87.5	111	135	156	175
200	100	126	155	178	200
250	125	158	193	224	250
300	150	189	232	268	300
400	200	253	310	358	400

* „Nozzle No.“ is capacity in GPH @ 100 PSI water pressure



ACCESSORIES

Kits & Nozzle Accessories for your needs

ACCESSORIES



MULTIPLE NOZZLE ADAPTORS



NOZZLE CASE



TEST KIT



NO DRIP



NOZZLE REMOVER



AAMA KIT

MORE INFORMATION

For further information feel free to contact us.



MONARCH NOZZLES

Oilburner nozzles | Industrial Nozzles | Water Nozzles

ATOMIZING NOZZLES | HOLLOW CONE NOZZLES | SOLID CONE NOZZLES | FLAT SPRAY NOZZLES

MONARCH NOZZLES

7249-B Browning Road
Pennsauken, NJ 08109

Email: hbeccari@monarchnozzles.com

Phone: 1-856-241-1500