

# FUJITSU



## STANDARD EFFICIENCY AIR HANDLER

### Features

- Versatile 4-way convertible design for upflow, downflow, horizontal left and horizontal right applications.
- Factory-installed indoor coil.
- Sturdy cabinet construction with 1.0 inch [25.4 mm] of foil faced insulation for excellent sound and insulating characteristics.
- Field-installed auxiliary electric heater kits provide exact heat for indoor comfort. Kits include circuit breakers which meet U.L. and cUL requirements for service disconnect.
- 1 1/2 ton [5.3 kW] through 5 ton [17.6 kW] models are between 42 1/2 to 55 1/2 inches [1080 to 1410 mm] tall and 22 inches [559 mm] deep.
- All models meet or exceed 330 to 400 CFM [156 to 189 L/s] per ton at .3 inches [.7 kPa] of external static pressure.
- Enhanced airflow up to .7" external static pressure.
- Evaporator is constructed of aluminum fins bonded to internally grooved aluminum tubing.
- Cabinet air leakage less than 2.0% at 1.0 inch H<sub>2</sub>O when tested in accordance with ASHRAE Standard 193.

### FH\*\*TPS SERIES

PSC Motor

Efficiencies: Up to 15 SEER

Manufactured for

**Fujitsu General America, Inc.**

Fairfield, NJ



## TABLE OF CONTENTS

Engineering Features .....	3
Model Number Identification .....	4
Dimensional Data.....	5
Airflow Directional Data .....	6
Airflow Performance Data .....	7-11
Electrical Data .....	15
Electrical Wiring .....	16
Limited Warranty .....	17

## Engineering Features

- The most compact unit design available, all standard heat air handler models only 42<sup>1</sup>/<sub>2</sub> to 55<sup>1</sup>/<sub>2</sub> inches [1079 to 1409 mm] high.
- Attractive pre-painted cabinet exterior.
- Rugged wall steel cabinet construction, designed for added strength and versatility.
- 1.0" foil faced insulation mechanically retained in blower compartment for excellent thermal and sound performance.
- Four leg blower motor mount.
- Blower housing with controls, motor and blower. Slide out design for service and maintenance convenience.
- Traditional open wire element design for heat applications.
- Field convertible for vertical downflow, horizontal left hand or right hand air supply.
- 3 combustible floor base accessories fit all model sizes when required for downflow installations on combustible floors.
- Indoor coil design provides low air side pressure drop, high performance and extremely compact size.
- Expansion valve on indoor coil provides for operation with air conditioning.
- Coils are constructed of aluminum fins bonded to internally grooved aluminum tubing.
- Coils are tested at the factory with an extensive refrigerant leak check.
- Coils have copper sweat refrigerant connections.
- Coils utilize chatleff metering device connections.
- Molded polymer corrosion resistant condensate drain pan is provided on all indoor coils.
- Supply duct flanges provided as standard on air handler cabinet.
- Provisions for field electrical, connections available from either side or top of the air handler cabinet.
- Connection point for high voltage wiring is inside the air handler cabinet. Low voltage connection is made on the outside of the air handler cabinet.
- Concentric knockouts are provided for power connection to cabinet. Installer may pull desired hole size up to 2 inches [51 mm] for 1<sup>1</sup>/<sub>2</sub> inch [38 mm] conduit.
- Front refrigerant and drain connections.

[ ] Designates Metric Conversions

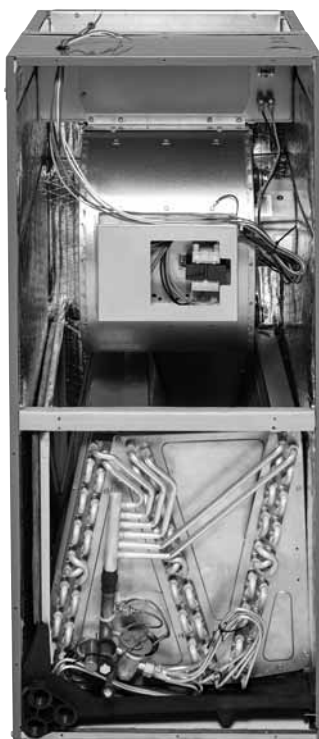

## Model Number Identification

<u>FH</u>	<u>18</u>	<u>17</u>	<u>T</u>	<u>P</u>	<u>S</u>	<u>V</u>	<u>95</u>	<u>00</u>	<u>N</u>	
Product	Capacity		Width	Metering Device	Motor	Speed	Volt	Efficiency	Heater	Communication
Air Handler	18 = 18,000	[5.28 kW]	17"	T = TEV	P = PSC	S = Single Stage	A = 115 1ph	S = Standard		N = Non-Communicating
FH = H Series	24 = 24,000	[7.03 kW]	21"				J = 208/230 1ph			
	30 = 30,000	[8.79 kW]	24"				D = 460 3ph			
	36 = 36,000	[10.55 kW]								
	42 = 42,000	[12.31 kW]								
	48 = 48,000	[14.07 kW]								
	60 = 60,000	[17.58 kW]								

[ ] Designates Metric Conversions

<i>Available Models at 115V A Voltage</i>
FH1817TPSASN
FH2417TPSASN
FH3017TPSASN
FH3617TPSASN
FH3617TPSJS
FH4221TPSASN
FH4821TPSASN

<i>Available Models at 218V J Voltage</i>
FH1817TPSJSN
FH2417TPSJSN
FH3017TPSJSN
FH3617TPSJSN
FH3621TPSJSN
FH4221TPSJSN
FH4821TPSJSN
FH4824TPSJSN
FH6024TPSJSN

<i>Available Models at D Voltage</i>
FH3617TPSDSN
FH3621TPSDSN
FH4221TPSDSN
FH4821TPSDSN
FH4824TPSDSN
FH6024TPSDSN

## Unit Dimensions

ELECTRICAL CONNECTIONS  
MAY EXIT TOP OR EITHER SIDE

HIGH VOLTAGE CONNECTION 7/8" [22.2 mm],  
1 3/32" [27.8 mm], 1 1/32" [50 mm] DIA. KNOCKOUTS.

LOW VOLTAGE CONNECTION  
5/8" [15.9 mm] AND 7/8" [22.2 mm] KNOCKOUT

AUXILIARY DRAIN CONNECTION  
3/4" [19.1 mm] FEMALE PIPE THREAD (NPT)  
HORIZONTAL APPLICATION ONLY

PRIMARY DRAIN CONNECTION  
3/4" [19.1 mm] FEMALE PIPE THREAD (NPT)

AUXILIARY DRAIN CONNECTION  
3/4" [19.1 mm] FEMALE PIPE THREAD (NPT)  
UPFLOW/DOWNFLOW APPLICATION ONLY

LIQUID LINE CONNECTION  
COPPER (SWEAT)

VAPOR LINE CONNECTION  
COPPER (SWEAT)

SUPPLY AIR ↑

NOTE: 24" CLEARANCE REQUIRED IN FRONT OF  
UNIT FOR FILTER AND COIL MAINTENANCE.

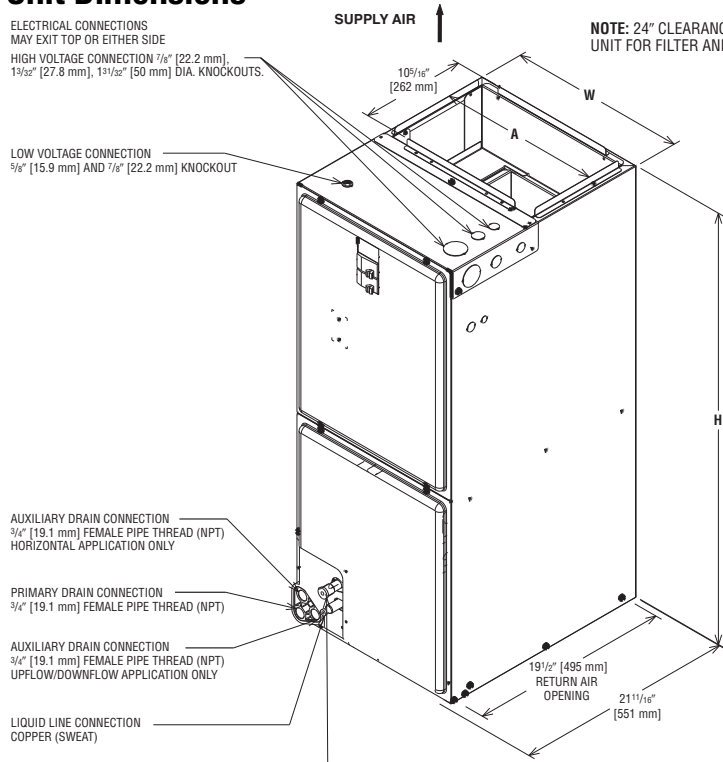

UPFLOW UNIT SHOWN:  
UNIT MAY BE INSTALLED UPFLOW, DOWNFLOW,  
HORIZONTAL RIGHT OR LEFT AIR SUPPLY.

HORIZONTAL ADAPTER KIT

VAPOR LINE  
CONNECTION

AUXILIARY HORIZONTAL  
DRAIN CONNECTION

PRIMARY DRAIN  
CONNECTION

LIQUID LINE  
CONNECTION

VERTICAL DRAIN PAN

AUXILIARY UPFLOW/DOWNFLOW  
DRAIN CONNECTION

## Return Air Opening Dimensions

Model Cabinet Size	Return Air Opening Width (Inches)	Return Air Opening Depth/Length (Inches)
17	15 7/8	19 3/4
21	19 3/8	19 3/4
24	22 7/8	19 3/4

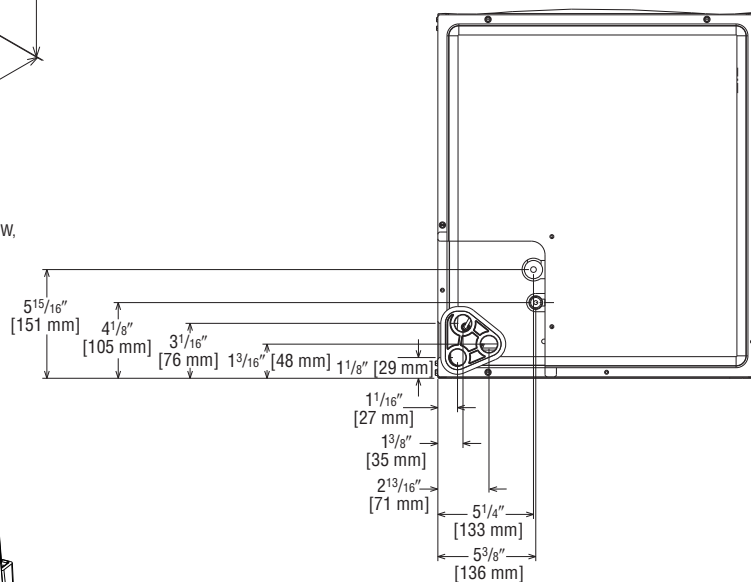

UPFLOW UNIT SHOWN:  
UNIT MAY BE INSTALLED UPFLOW,  
DOWNFLOW, HORIZONTAL RIGHT  
OR LEFT AIR SUPPLY.

[ ] Designates Metric Conversions

( ) Designates Unit with Double Coil Cabinet

## Unit Dimensions & Weights

Model Size FH**TPS	Refrigerant Connections Sweat (In.) [mm] ID		Unit Width "W" In. [mm]	Unit Height "H" In. [mm]	Supply Duct "A" In. [mm]	Air Flow CFM (Nom.) [L/s]		Unit Weight/Shipping Weight (Lbs.) [kg] Unit With Coil (Max. KW)
	Liquid	Vapor				Lo	Hi	
1817/2417	3/8 [9.53]	3/4 [19.05]	17 1/2 [445]	42 1/2 [1080]	16 [406]	600 [283]	800 [378]	81/95 [37/43]
3017/3617	3/8 [9.53]	3/4 [19.05]	17 1/2 [445]	42 1/2 [1080]	16 [406]	1000 [472]	1200 [566]	90/104 [41/47]
3621	3/8 [9.53]	7/8 [22.23]	21 [533]	42 1/2 [1080]	19 1/2 [495]	1200 [566]	—	109/124 [49/56]
4221/4821	3/8 [9.53]	7/8 [22.23]	21 [533]	50 1/2 [1282]	19 1/2 [495]	1400 [661]	1600 [755]	130/146 [59/66]
4824	3/8 [9.53]	7/8 [22.23]	24 1/2 [622]	50 1/2 [1282]	23 [584]	1600 [755]	—	143/161 [65/73]
6024	3/8 [9.53]	7/8 [22.23]	24 1/2 [622]	55 1/2 [1410]	23 [584]	—	1800 [850]	164/181 [75/82]

\*Maximum dehumidification airflow.

## Airflow Directional Data

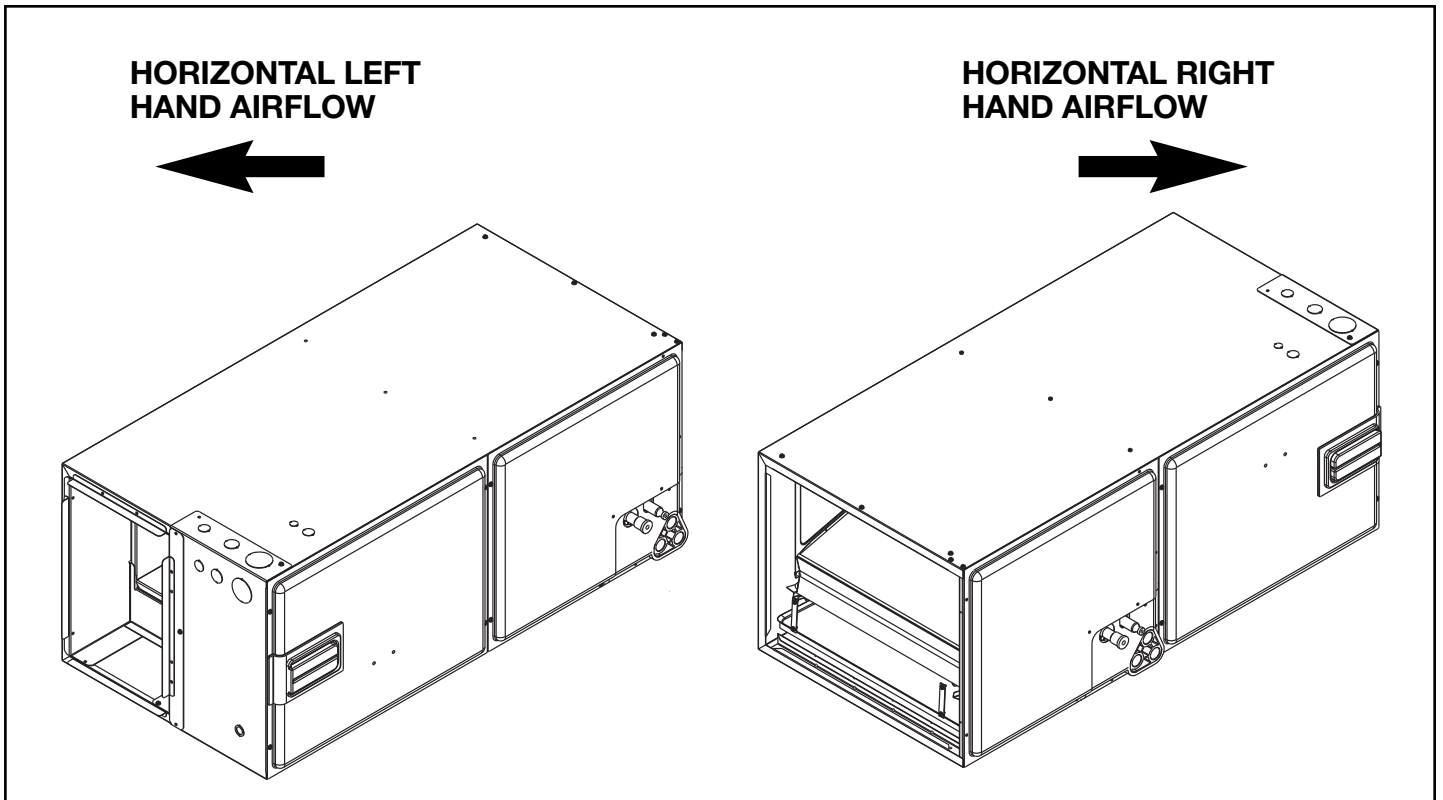
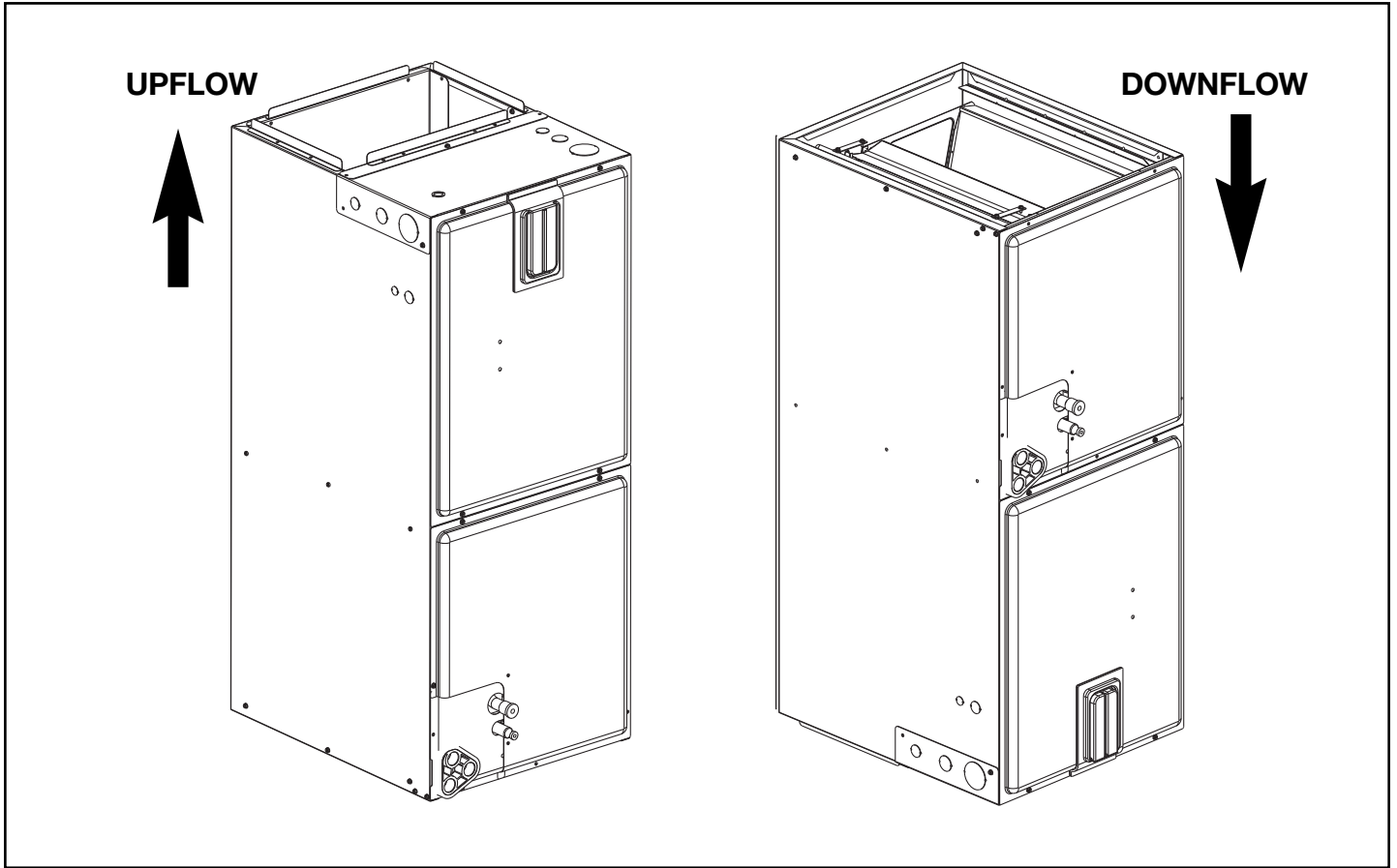

## Airflow Performance

**Airflow performance data is based on cooling performance with a coil and no filter in place.** Select performance table for appropriate unit size, voltage and number of electric heaters to be used. Make sure external static applied to unit allows operation within the minimum and maximum limits shown in table

below for both cooling and electric heat operation. For optimum blower performance, operate the unit in the .3 [8 mm] to .7 inches [18 mm] W.C. external static range. Units with coils should be applied with a minimum of .1 inch [3 mm] W.C. external static range.

## Airflow Operating Limits

Model Cabinet Width	17		17/21		21		24	
Cooling BTUH x 1,000 Cooling Tons Nominal	-18 1.5	-24 2	-30 2.5	-36 3	-42 3.5	-48 4	-48 4	-60 5
Heat Pump or Air Conditioning Maximum Heat/Cool CFM [L/s] (37.5 CFM [18 L/s]/1,000 BTUH) (450 CFM [212 L/s]/Ton Nominal)	675 [319]	900 [425]	1125 [531]	1350 [637]	1575 [743]	1800 [850]	1800 [850]	1930 [911]
Heat Pump or Air Conditioning Nominal Heat/Cool CFM [L/s] (33.3 CFM [16 L/s]/1,000 BTUH) (400 CFM [189 L/s]/Ton Nominal)	600 [283]	800 [378]	1000 [472]	1200 [566]	1400 [661]	1600 [755]	1600 [755]	1800 [850]
Heat Pump or Air Conditioning Minimum Heat/Cool CFM [L/s] (30.0 CFM [14 L/s]/1,200 BTUH) (360 CFM [170 L/s]/Ton Nominal)	540 [255]	720 [340]	900 [425]	1080 [510]	1260 [595]	1440 [680]	1440 [680]	1620 [765]
Maximum kW Electric Heating & Minimum Electric Heat CFM [L/s]	13 487 [230]	13 617 [291]	18 814 [384]	18 1054 [497]	20 1171 [553]	25 1502 [709]	25 1502 [709]	30 1666 [786]
Maximum Electric Heat Rise °F [°C]	80 [26.7]	63 [17.2]	66 [18.9]	51 [10.6]	49 [9.4]	50 [10]	50 [10]	54 [12.2]

[ ] Designates Metric Conversions

## 115V/208V/480V Airflow Performance Data—FH\*\*TPS (PSC Motor)

Model No. FH**TPS	Motor Speed from Factory	Manufacturer Recommended Air-Flow Range (Min/Max) CFM	Blower Size/ Motor HP [W] # of Speed	Motor Speed	PSC CFM [L/s] Air Delivery/RPM/Watts—115V/208V/480V Volts							
					External Static Pressure—Inches W.C. [kPa]							
					0.1 [.02]	0.2 [.05]	0.3 [.07]	0.4 [.10]	0.5 [.12]	0.6 [.15]	0.7 [.17]	
1817 No Heater	High 240V	517/711 CFM [244/336 L/s]	10x6 1/5 HP [149] 2 Speed	Low	CFM	668 [315]	637 [301]	595 [281]	560 [264]	517 [244]	—	—
					RPM	541	596	657	706	761	—	—
					Watts	180	171	166	161	109	—	—
				High	CFM	—	—	—	—	711 [336]	662 [312]	614 [290]
					RPM	—	—	—	—	812	853	890
					Watts	—	—	—	—	243	227	210
1817 with 13 kW Heater	High 240V	487/661 CFM [230/312 L/s]	10x6 1/5 HP [149] 2 Speed	Low	CFM	638 [301]	607 [286]	565 [267]	530 [250]	487 [230]	—	—
					RPM	571	626	687	736	791	—	—
					Watts	171	162	157	152	146	—	—
				High	CFM	—	—	—	—	661 [312]	612 [289]	564 [266]
					RPM	—	—	—	—	837	878	915
					Watts	—	—	—	—	232	216	199
2417 No Heater	High 240V	647/888 CFM [305/419 L/s]	10x6 1/5 HP [149] 2 Speed	Low	CFM	817 [386]	779 [368]	757 [357]	693 [327]	647 [305]	—	—
					RPM	616	667	715	770	808	—	—
					Watts	239	230	221	206	205	—	—
				High	CFM	—	—	—	—	888 [419]	828 [391]	774 [365]
					RPM	—	—	—	—	875	908	958
					Watts	—	—	—	—	331	313	301
2417 with 13 kW Heater	High 240V	617/838 CFM [291/395 L/s]	10x6 1/5 HP [149] 2 Speed	Low	CFM	787 [371]	749 [353]	727 [343]	663 [313]	617 [291]	—	—
					RPM	646	697	745	800	838	—	—
					Watts	230	221	212	197	187	—	—
				High	CFM	—	—	—	—	838 [395]	778 [367]	724 [342]
					RPM	—	—	—	—	900	933	983
					Watts	—	—	—	—	320	302	290
3017 No Heater	High 240V	864/1004 CFM [408/474 L/s]	10x8 1/4 HP [186] 2 Speed	Low	CFM	1022 [482]	987 [466]	940 [444]	903 [426]	864 [408]	—	—
					RPM	700	754	794	633	870	—	—
					Watts	344	313	302	309	288	—	—
				High	CFM	—	—	—	—	1004 [474]	951 [449]	883 [417]
					RPM	—	—	—	—	924	953	975
					Watts	—	—	—	—	364	352	344
3017 with 18 kW Heater	High 240V	814/904 CFM [384/427 L/s]	10x8 1/4 HP [186] 2 Speed	Low	CFM	972 [459]	937 [442]	890 [420]	853 [403]	814 [384]	—	—
					RPM	750	804	844	883	920	—	—
					Watts	324	293	282	274	268	—	—
				High	CFM	—	—	—	—	904 [427]	851 [402]	783 [370]
					RPM	—	—	—	—	949	978	1000
					Watts	—	—	—	—	334	322	314
3617/ 3621 No Heater	High	1104/1248 CFM [521/589 L/s]	10x8 1/3 HP [249] 2 Speed	Low	CFM	1201 [567]	1170 [552]	1141 [538]	1104 [521]	1062 [501]	—	—
					RPM	833	872	909	951	965	—	—
					Watts	462	427	406	396	385	—	—
				High	CFM	—	—	—	—	1194 [563]	1134 [535]	1078 [509]
					RPM	—	—	—	—	1024	1042	1060
					Watts	—	—	—	—	475	454	417

- Notes:
- All 208/240V PSC motors have voltage taps for 208 and 240 volts.
  - All 208/240V PSC motors are shipped on high speed and 240 volts.
  - If the application external static is less than 0.5" WC, adjust the motor speed to the low static speed as described below:
    - Unplug the black motor wire off the relay on the control board and plug in the red motor wire.
    - Replace the cap on the black motor wire.
  - Voltage change (208/240V motors):
    - Move the orange lead to transformer 208V tap from 240V tap. Replace the wire cap on 240V tap.
    - Unplug the purple motor wire off the transformer and plug in the yellow motor wire.
    - Replace the cap on the purple motor wire.
  - The above airflow table lists the airflow information for air handlers without heater and air handler with maximum heater allowed for each model.
  - The following formula can be used to calculate the approximate airflow, if a smaller (N kW) than the maximum heater kit is installed.  
 Approximate Airflow = Airflow without heater - (Airflow without heater - Airflow with maximum heater) x (N kW/maximum heater kW)

[ ] Designates Metric Conversions



## 115V/208V/480V Airflow Performance Data—FH\*\*TPS (PSC Motor)

Model No. FH**TPS	Motor Speed from Factory	Manufacturer Recommended Air-Flow Range (Min/Max) CFM	Blower Size/ Motor HP [W] # of Speed	Motor Speed	PSC CFM [L/s] Air Delivery/RPM/Watts—115/208/480V Volts							
					External Static Pressure—Inches W.C. [kPa]							
					0.1 [.02]	0.2 [.05]	0.3 [.07]	0.4 [.10]	0.5 [.12]	0.6 [.15]	0.7 [.17]	
3617/ 3621 with 18 kW Heater	High	1054/1148 CFM [497/542 L/s]	10x8 1/3 HP [249] 2 Speed	Low	CFM	1151 [543]	1120 [529]	1091 [515]	1054 [497]	1012 [478]	—	—
					RPM	883	922	959	1001	1015	—	—
					Watts	442	407	386	376	365	—	—
				High	CFM	—	—	—	—	1094 [516]	1034 [488]	978 [462]
					RPM	—	—	—	—	1049	1067	1085
					Watts	—	—	—	—	445	424	387
4221 No Heater	High	1241/1537 CFM [580/725 L/s]	10x10 1/2 HP [373] 2 Speed	Low	CFM	1493 [705]	1449 [684]	1363 [643]	1287 [607]	1211 [571]	—	—
					RPM	822	858	885	931	958	—	—
					Watts	540	519	506	484	459	—	—
				High	CFM	—	—	—	—	1514 [714]	1411 [666]	1315 [621]
					RPM	—	—	—	—	1061	1069	1078
					Watts	—	—	—	—	710	702	677
4221 with 20 kW Heater	High	1225/1500 CFM [538/667 L/s]	10x10 1/2 HP [373] 2 Speed	Low	CFM	1423 [672]	1379 [651]	1293 [610]	1217 [574]	1141 [538]	—	—
					RPM	870	882	925	957	992	—	—
					Watts	514	508	490	461	431	—	—
				High	CFM	—	—	—	—	1414 [667]	1311 [619]	1215 [573]
					RPM	—	—	—	—	1067	1080	1094
					Watts	—	—	—	—	700	678	665
4821/ 4824 No Heater	High	1395/1824 CFM [658/861 L/s]	10x10 3/4 HP [559] 2 Speed	Low	CFM	1488 [702]	1419 [670]	1466 [692]	1430 [675]	1395 [658]	—	—
					RPM	812	861	912	943	973	—	—
					Watts	554	545	526	508	491	—	—
				High	CFM	—	—	—	—	1824 [861]	1767 [834]	1653 [780]
					RPM	—	—	—	—	1102	1112	1121
					Watts	—	—	—	—	871	830	770
4821/ 4824 with 25 kW Heater	High	1225/1500 CFM [695/796 L/s]	10x10 3/4 HP [559] 2 Speed	Low	CFM	1418 [669]	1349 [637]	1396 [659]	1360 [642]	1325 [625]	—	—
					RPM	862	899	935	965	995	—	—
					Watts	534	525	506	488	471	—	—
				High	CFM	—	—	—	—	1724 [814]	1667 [787]	1553 [733]
					RPM	—	—	—	—	1116	1119	1130
					Watts	—	—	—	—	810	780	730
6024 No Heater	High	1766/1965 CFM [833/927 L/s]	11x11 3/4 HP [559] 2 Speed	Low	CFM	1866 [881]	1833 [865]	1806 [852]	1772 [836]	1710 [807]	—	—
					RPM	764	803	824	856	886	—	—
					Watts	778	756	733	715	701	—	—
				High	CFM	—	—	—	—	1967 [928]	1916 [904]	1863 [879]
					RPM	—	—	—	—	948	959	991
					Watts	—	—	—	—	850	827	816
6024 with 30 kW Heater	High	1225/1500 CFM [695/796 L/s]	11x11 3/4 HP [559] 2 Speed	Low	CFM	1796 [848]	1763 [832]	1736 [819]	1702 [803]	1640 [774]	—	—
					RPM	828	860	878	890	1001	—	—
					Watts	735	718	705	695	678	—	—
				High	CFM	—	—	—	—	1867 [881]	1816 [857]	1763 [832]
					RPM	—	—	—	—	989	1005	1020
					Watts	—	—	—	—	818	795	780

- Notes:
- All 208/240V PSC motors have voltage taps for 208 and 240 volts.
  - All 208/240V PSC motors are shipped on high speed and 240 volts.
  - All 115V PSC motors are shipped on high speed.
  - If the application external static is less than 0.5" WC, adjust the motor speed to the low static speed as described below:
    - Unplug the black motor wire off the relay on the control board and plug in the red motor wire.
    - Replace the cap on the black motor wire.
  - Voltage change (208/240V motors):
    - Move the orange lead to transformer 208V tap from 240V tap.
    - Replace the wire cap on 240V tap.
    - Unplug the purple motor wire off the transformer and plug in the yellow motor wire.
    - Replace the cap on the purple motor wire.
  - All 480V PSC motors are shipped on high speed.
  - If the application external static is less than 0.5" WC, adjust the motor speed to the low static speed as described below for 3-ton through 4-ton air handlers.

- Unplug the black motor wire off the relay and remove the cap from the red motor wire.
- Plug the red motor wire to the relay and connect the black motor wire with the yellow motor wire.
- For 5-ton air handler, unplug the black motor wire off the relay and plug in the red motor wire, then cap the black motor wire. There is no yellow motor wire on 5-ton air handler.

**WARNING:** Do not connect red motor wire with yellow motor wire in any circumstance on 480V PSC motors. Connecting red motor wire with yellow motor wire will result in permanent motor damage.

- The above airflow table lists the airflow information for air handlers without heater and air handler with maximum heater allowed for each model.
- The following formula can be used to calculate the approximate airflow, if a smaller (N kW) than the maximum heater kit is installed. Approximate Airflow = Airflow without heater - (Airflow without heater - Airflow with maximum heater) x (N kW/maximum heater kW)

[ ] Designates Metric Conversions

## 240V Airflow Performance Data—FH\*\*TPS (PSC Motor)

Model No. FH**TPS	Motor Speed from Factory	Manufacturer Recommended Air-Flow Range (Min/Max) CFM	Blower Size/ Motor HP [W] # of Speed	Motor Speed	PSC CFM [L/s] Air Delivery/RPM/Watts—240 Volts							
					External Static Pressure—Inches W.C. [kPa]							
					0.1 [.02]	0.2 [.05]	0.3 [.07]	0.4 [.10]	0.5 [.12]	0.6 [.15]	0.7 [.17]	
1817 No Heater	High	523/705 CFM [247/333 L/s]	10x6 1/5 HP [149] 2 Speed	Low	CFM	681 [321]	636 [300]	606 [286]	567 [268]	523 [247]	—	—
					RPM	541	601	670	714	768	—	—
					Watts	193	181	173	164	157	—	—
				High	CFM	—	—	—	—	705 [333]	650 [307]	599 [283]
					RPM	—	—	—	—	815	861	989
					Watts	—	—	—	—	239	227	204
1817 with 13 kW Heater	High	487/661 CFM [230/312 L/s]	10x6 1/5 HP [149] 2 Speed	Low	CFM	651 [307]	606 [286]	576 [272]	537 [253]	493 [233]	—	—
					RPM	571	631	700	744	798	—	—
					Watts	184	172	164	155	148	—	—
				High	CFM	—	—	—	—	655 [309]	600 [283]	549 [259]
					RPM	—	—	—	—	840	886	1014
					Watts	—	—	—	—	228	216	193
2417 No Heater	High	647/888 CFM [305/419 L/s]	10x6 1/5 HP [149] 2 Speed	Low	CFM	875 [413]	806 [380]	787 [371]	739 [349]	682 [322]	—	—
					RPM	648	700	745	794	827	—	—
					Watts	259	255	243	234	227	—	—
				High	CFM	—	—	—	—	897 [423]	851 [402]	765 [361]
					RPM	—	—	—	—	906	925	955
					Watts	—	—	—	—	332	318	306
2417 with 13 kW Heater	High	617/838 CFM [291/395 L/s]	10x6 1/5 HP [149] 2 Speed	Low	CFM	845 [399]	776 [366]	757 [357]	709 [335]	652 [308]	—	—
					RPM	678	730	775	824	857	—	—
					Watts	250	246	234	225	218	—	—
				High	CFM	—	—	—	—	847 [400]	801 [378]	715 [337]
					RPM	—	—	—	—	931	950	980
					Watts	—	—	—	—	321	307	295
3017 No Heater	High	864/1004 CFM [408/474 L/s]	10x8 1/4 HP [186] 2 Speed	Low	CFM	1038 [490]	1010 [477]	976 [461]	925 [437]	883 [417]	—	—
					RPM	721	771	799	848	880	—	—
					Watts	325	314	303	290	286	—	—
				High	CFM	—	—	—	—	1015 [479]	963 [454]	890 [420]
					RPM	—	—	—	—	928	955	974
					Watts	—	—	—	—	356	341	329
3017 with 18 kW Heater	High	814/904 CFM [384/427 L/s]	10x8 1/4 HP [186] 2 Speed	Low	CFM	988 [466]	960 [453]	926 [437]	875 [413]	833 [393]	—	—
					RPM	771	821	849	898	930	—	—
					Watts	305	294	283	270	266	—	—
				High	CFM	—	—	—	—	915 [432]	863 [407]	790 [373]
					RPM	—	—	—	—	953	980	999
					Watts	—	—	—	—	326	311	299
3617/ 3621 No Heater	High 240V	1104/1248 CFM [521/589 L/s]	10x8 1/3 HP [249] 2 Speed	Low	CFM	1229 [580]	1201 [567]	1170 [552]	1141 [538]	1104 [521]	—	—
					RPM	788	833	872	909	951	—	—
					Watts	466	462	427	406	395	—	—
				High	CFM	—	—	—	—	1248 [589]	1194 [563]	1133 [535]
					RPM	—	—	—	—	1008	1028	1042
					Watts	—	—	—	—	488	475	454

- Notes:
- All 208/240V PSC motors have voltage taps for 208 and 240 volts.
  - All 208/240V PSC motors are shipped on high speed and 240 volts.
  - All 115V PSC motors are shipped on high speed.
  - If the application external static is less than 0.5" WC, adjust the motor speed to the low static speed as described below:
    - Unplug the black motor wire off the relay on the control board and plug in the red motor wire.
    - Replace the cap on the black motor wire.
  - Voltage change (208/240V motors):
    - Move the orange lead to transformer 208V tap from 240V tap.
    - Replace the wire cap on 240V tap.
    - Unplug the purple motor wire off the transformer and plug in the yellow motor wire.
    - Replace the cap on the purple motor wire.
  - All 480V PSC motors are shipped on high speed.
  - If the application external static is less than 0.5" WC, adjust the motor speed to the low static speed as described below for 3-ton through 4-ton air handlers.

- Unplug the black motor wire off the relay and remove the cap from the red motor wire.
- Plug the red motor wire to the relay and connect the black motor wire with the yellow motor wire.
- For 5-ton air handler, unplug the black motor wire off the relay and plug in the red motor wire, then cap the black motor wire. There is no yellow motor wire on 5-ton air handler.

**WARNING:** Do not connect red motor wire with yellow motor wire in any circumstance on 480V PSC motors. Connecting red motor wire with yellow motor wire will result in permanent motor damage.

• The above airflow table lists the airflow information for air handlers without heater and air handler with maximum heater allowed for each model.

• The following formula can be used to calculate the approximate airflow, if a smaller (N kW) than the maximum heater kit is installed. Approximate Airflow = Airflow without heater - (Airflow without heater - Airflow with maximum heater) x (N kW/maximum heater kW)

[ ] Designates Metric Conversions

## 240V Airflow Performance Data—FH\*\*TPS (PSC Motor)

Model No. FH**TPS	Motor Speed from Factory	Manufacturer Recommended Air-Flow Range (Min/Max) CFM	Blower Size/ Motor HP [W] # of Speed	Motor Speed	PSC CFM [L/s] Air Delivery/RPM/Watts—240 Volts							
					External Static Pressure—Inches W.C. [kPa]							
					0.1 [.02]	0.2 [.05]	0.3 [.07]	0.4 [.10]	0.5 [.12]	0.6 [.15]	0.7 [.17]	
3617/ 3621 with 18 kW Heater	High 240V	1054/1148 CFM [497/542 L/s]	10x8 1/3 HP [249] 2 Speed	Low	CFM	1179 [556]	1151 [543]	1120 [529]	1091 [515]	1054 [497]	—	—
					RPM	838	883	922	959	1001	—	—
					Watts	446	442	407	386	375	—	—
				High	CFM	—	—	—	—	1148 [542]	1094 [516]	1033 [487]
					RPM	—	—	—	—	1033	1053	1067
					Watts	—	—	—	—	458	445	424
4221 No Heater	High 240V	1241/1537 CFM [586/725 L/s]	10x10 1/2 HP [373] 2 Speed	Low	CFM	1526 [720]	1474 [696]	1427 [673]	1307 [617]	1241 [586]	—	—
					RPM	834	870	902	948	968	—	—
					Watts	560	549	535	476	462	—	—
				High	CFM	—	—	—	—	1537 [725]	1418 [669]	1334 [630]
					RPM	—	—	—	—	1072	1077	1085
					Watts	—	—	—	—	860	835	820
4221 with 20 kW Heater	High 240V	1225/1500 CFM [553/678 L/s]	10x10 1/2 HP [373] 2 Speed	Low	CFM	1456 [687]	1404 [663]	1357 [640]	1237 [584]	1171 [553]	—	—
					RPM	886	906	925	959	992	—	—
					Watts	542	524	505	468	431	—	—
				High	CFM	—	—	—	—	1437 [678]	1318 [622]	1234 [582]
					RPM	—	—	—	—	1080	1090	1105
					Watts	—	—	—	—	840	800	785
4821/ 4824 No Heater	High 240V	1455/1787 CFM [687/843 L/s]	10x10 3/4 HP [559] 2 Speed	Low	CFM	1560 [736]	1550 [731]	1543 [728]	1510 [713]	1455 [687]	—	—
					RPM	807	840	914	941	989	—	—
					Watts	601	589	553	541	507	—	—
				High	CFM	—	—	—	—	1787 [843]	1679 [792]	1575 [743]
					RPM	—	—	—	—	1089	1098	1110
					Watts	—	—	—	—	695	665	630
4821/ 4824 with 25 kW Heater	High 240V	1225/1500 CFM [709/814 L/s]	10x10 3/4 HP [559] 2 Speed	Low	CFM	1490 [703]	1480 [698]	1473 [695]	1440 [680]	1385 [654]	—	—
					RPM	857	897	937	974	1011	—	—
					Watts	581	569	533	521	487	—	—
				High	CFM	—	—	—	—	1687 [796]	1579 [745]	1475 [696]
					RPM	—	—	—	—	1095	1107	1120
					Watts	—	—	—	—	670	635	615
6024 No Heater	High 240V	1766/1965 CFM [833/927 L/s]	11x11 3/4 HP [559] 2 Speed	Low	CFM	1944 [917]	1912 [902]	1860 [878]	1813 [856]	1766 [833]	—	—
					RPM	764	803	838	865	889	—	—
					Watts	779	763	747	729	708	—	—
				High	CFM	—	—	—	—	1965 [927]	1908 [900]	1854 [875]
					RPM	—	—	—	—	943	967	977
					Watts	—	—	—	—	828	799	795
6024 with 30 kW Heater	High 240V	1225/1500 CFM [709/814 L/s]	11x11 3/4 HP [559] 2 Speed	Low	CFM	1844 [870]	1812 [855]	1760 [831]	1713 [808]	1666 [786]	—	—
					RPM	839	865	890	913	935	—	—
					Watts	745	729	713	696	678	—	—
				High	CFM	—	—	—	—	1865 [880]	1808 [853]	1754 [828]
					RPM	—	—	—	—	987	1001	1014
					Watts	—	—	—	—	788	766	744

- Notes:
- All 208/240V PSC motors have voltage taps for 208 and 240 volts.
  - All 208/240V PSC motors are shipped on high speed and 240 volts.
  - If the application external static is less than 0.5" WC, adjust the motor speed to the low static speed as described below:
    - Unplug the black motor wire off the relay on the control board and plug in the red motor wire.
    - Replace the cap on the black motor wire.
  - Voltage change (208/240V motors):
    - Move the orange lead to transformer 208V tap from 240V tap. Replace the wire cap on 240V tap.
    - Unplug the purple motor wire off the transformer and plug in the yellow motor wire.
    - Replace the cap on the purple motor wire.
  - The above airflow table lists the airflow information for air handlers without heater and air handler with maximum heater allowed for each model.
  - The following formula can be used to calculate the approximate airflow, if a smaller (N kW) than the maximum heater kit is installed.  
Approximate Airflow = Airflow without heater - (Airflow without heater - Airflow with maximum heater) x (N kW/maximum heater kW)

[ ] Designates Metric Conversions

## Electrical Data – Blower Motor Only – No Electric Heat

Model FH**TPS	Voltage	Application Phase*	Hertz	HP [W]	RPM	Speeds	Circuit Amps.	Minimum Circuit Ampacity	Maximum Circuit Protector
1817	115	1	60	1/5 [149]	1075	2	2.3	3.0	15
2417				1/5 [149]	1075	2	3.8	5.0	15
3017				1/4 [186]	1075	2	4.7	6.0	15
3617				1/3 [249]	1075	2	6.1	8.0	15
4221				1/2 [373]	1075	2	7.9	10.0	15
4821				3/4 [559]	1075	2	8.4	11.0	15
1817	208/240	1 & 3	60	1/5 [149]	1075	2	1.7	3.0	15
2417				1/5 [149]	1075	2	1.7	3.0	15
3017				1/4 [186]	1075	2	2.5	4.0	15
3617/3621				1/3 [249]	1075	2	2.5	4.0	15
4221				1/2 [373]	1075	2	5.2	7.0	15
4821/4824				3/4 [559]	1075	2	5.2	7.0	15
6024	208/240	3	60	3/4 [559]	1075	2	5.2	7.0	15
3617	480	3	60	1/3 [249]	1075	2	1.4	2.0	15
4221				1/3 [249]	1075	2	2.1	3.0	15
4821/4824				3/4 [559]	1075	2	2.2	3.0	15
6024	480	3	60	3/4 [559]	1075	2	2.2	3.0	15

\* Blower motors are all single phase motors.

[ ] Designates Metric Conversions

## Electrical Data – With Electric Heat

Installation of the U.L. Listed original equipment manufacturer provided heater kits listed in the following table is recommended for all auxiliary heating requirements.

Air Handler Model FH**TPS	Heater Model No.	Heater kW (208/240V) (480V)	PH/HZ	No. Elements kW Per	Type Supply Circuit Single Circuit Multiple	Circuit Amps.	Motor Ampacity	Minimum Circuit Ampacity	Maximum Circuit Protection
1817/2417	RXBH-1724?03J	2.25/3.0	1/60	1 - 3.0	SINGLE	10.8/12.5	1.7	16/18	20/20
	RXBH-1724?05J	3.6/4.8	1/60	1 - 4.8	SINGLE	17.3/20.0	1.7	24/28	25/30
	RXBH-1724?07J	5.4/7.2	1/60	2 - 3.6	SINGLE	26.0/30.0	1.7	35/40	35/40
	RXBH-1724?10J	7.2/9.6	1/60	2 - 4.8	SINGLE	34.6/40.0	1.7	46/53	50/60
	RXBH-1724A13J	9.4/12.5	1/60	3-4.17	SINGLE	45.1/52.1	1.7	59/68	60/70
	RXBH-1724A13J	3.1/4.2	1/60	1-4.17	MULTIPLE CKT 1	15./17.4	1.7	21/24	25/25
		6.3/8.3	1/60	2-4.17	MULTIPLE CKT 2	30.1/34.7	0.0	38/44	40/45
	RXBH-1724A07C	5.4/7.2	3/60	3 - 2.4	SINGLE	15.0/17.3	1.7	21/24	25/25
	RXBH-1724A10C	7.2/9.6	3/60	3 - 3.2	SINGLE	20.0/23.1	1.7	28/31	30/35
RXBH-1724A13C	9.4/12.5	3/60	3-4.17	SINGLE	26.1/30.1	1.7	35/40	35/40	
3017/3617	RXBH-1724?03J	2.25/3.0	1/60	1 - 3.0	SINGLE	10.8/12.5	2.5	17/19	20/20
	RXBH-1724?05J	3.6/4.8	1/60	1 - 4.8	SINGLE	17.3/20.0	2.5	25/29	25/30
	RXBH-1724?07J	5.4/7.2	1/60	2 - 3.6	SINGLE	26.0/30.0	2.5	36/41	40/45
	RXBH-1724?10J	7.2/9.6	1/60	2 - 4.8	SINGLE	34.6/40.0	2.5	47/54	50/60
	RXBH-1724A13J	9.4/12.5	1/60	3-4.17	SINGLE	45.1/52.1	2.5	60/69	60/70
	RXBH-1724A13J	3.1/4.2	1/60	1-4.17	MULTIPLE CKT 1	15.0/17.4	2.5	22/25	25/25
		6.3/8.3	1/60	2-4.17	MULTIPLE CKT 2	30.1/34.7	0.0	38/44	40/45
	RXBH-1724A15J	10.8/14.4	1/60	3-4.8	SINGLE	51.9/60.0	2.5	68/79	70/80
	RXBH-1724A15J	3.6/4.8	1/60	1 - 4.8	MULTIPLE CKT 1	17.3/20.0	2.5	25/29	25/30
		7.2/9.6	1/60	2 - 4.8	MULTIPLE CKT 2	34.6/40.0	0.0	44/50	45/50
	RXBH-1724A18J	12.8/17	1/60	3-5.68	SINGLE	61.6/70.8	2.5	81/92	90/100
	RXBH-1724A18J	4.3/5.7	1/60	1 - 5.68	MULTIPLE CKT 1	20.5/23.6	2.5	29/33	30/35
		8.7/11.3	1/60	2 - 5.68	MULTIPLE CKT 2	41.1/47.2	0.0	52/59	60/60
	RXBH-1724A07C	5.4/7.2	3/60	3 - 2.4	SINGLE	15.0/17.3	2.5	22/25	25/25
	RXBH-1724A10C	7.2/9.6	3/60	3 - 3.2	SINGLE	20.0/23.1	2.5	29/32	30/35
	RXBH-1724A13C	9.4/12.5	3/60	3-4.17	SINGLE	26.1/30.1	2.5	36/41	40/45
	RXBH-1724A15C	10.8/14.4	3/60	3 - 4.8	SINGLE	30.0/34.6	2.5	41/47	45/50
	RXBH-1724A18C	12.8/17.0	3/60	3-5.68	SINGLE	35.5/41.0	2.5	48.55	50/60
	RXBH-17A07D	7.2	3/60	2-3.6	SINGLE	8.7	1.4	13	15
	RXBH-17A10D	9.6	3/60	3-3.2	SINGLE	11.6	1.4	17	20
RXBH-17A15D	14.4	3/60	3-4.8	SINGLE	17.3	1.4	24	25	
RXBH-17A18D	17	3/60	3-5.68	SINGLE	20.4	1.4	28	30	
3621	RXBH-1724?05J	3.6/4.8	1/60	1 - 4.8	SINGLE	17.3/20.0	2.5	25/29	25/30
	RXBH-1724?07J	5.4/7.2	1/60	2 - 3.6	SINGLE	26.0/30.0	2.5	36/41	40/45
	RXBH-1724?10J	7.2/9.6	1/60	2 - 4.8	SINGLE	34.6/40.0	2.5	47/54	50/60
	RXBH-1724A13J	9.4/12.5	1/60	3-4.17	SINGLE	45.1/52.1	2.5	60/69	60/70
	RXBH-1724A13J	3.1/4.2	1/60	1-4.17	MULTIPLE CKT 1	15.0/17.4	2.5	22/25	25/25
		6.3/8.3	1/60	2-4.17	MULTIPLE CKT 2	30.1/34.7	0.0	38/44	40/45
	RXBH-1724A15J	10.8/14.4	1/60	3-4.8	SINGLE	51.9/60.0	2.5	68/79	70/80
	RXBH-1724A15J	3.6/4.8	1/60	1 - 4.8	MULTIPLE CKT 1	17.3/20.0	2.5	25/29	25/30
		7.2/9.6	1/60	2 - 4.8	MULTIPLE CKT 2	34.6/40.0	0.0	44/50	45/50
RXBH-1724A18J	12.8/17	1/60	3-5.68	SINGLE	61.6/70.8	2.5	81/92	90/100	

- Supply circuit protective devices may be fuses or “HACR” type circuit breakers.
- Largest motor load is included in single circuit and multiple circuit 1.
- If non-standard fuse size is specified, use next size larger standard fuse size.
- J Voltage (230V) single phase air handler is designed to be used with single or three phase 230 volt electric heaters. In the case of connecting 3-phase power to the air handler terminal block without the heater, bring only two leads to the terminal block cap, insulate and fully secure the third lead.

[ ] Designates Metric Conversions

## Electrical Data – With Electric Heat (Cont.)

Installation of the U.L. Listed original equipment manufacturer provided heater kits listed in the following table is recommended for all auxiliary heating requirements.

Air Handler Model FH**TPS	Heater Model No.	Heater kW (208/240V) (480V)	PH/HZ	No. Elements kW Per	Type Supply Circuit Single Circuit Multiple	Circuit Amps.	Motor Ampacity	Minimum Circuit Ampacity	Maximum Circuit Protection
3621	RXBH-1724A18J	4.3/5.7	1/60	1 - 5.68	MULTIPLE CKT 1	20.5/23.6	2.5	29/33	30/35
		8.7/11.3	1/60	2 - 5.86	MULTIPLE CKT 2	41.1/47.2	0.0	52/59	60/60
	RXBH-1724A07C	5.4/7.2	3/60	3 - 2.4	SINGLE	15.0/17.3	2.5	22/25	25/25
	RXBH-1724A10C	7.2/9.6	3/60	3 - 3.2	SINGLE	20.0/23.1	2.5	29/32	30/35
	RXBH-1724A13C	9.4/12.5	3/60	3-4.17	SINGLE	26.1/30.1	2.5	36/41	40/45
	RXBH-1724A15C	10.8/14.4	3/60	3 - 4.8	SINGLE	30.0/34.6	2.5	41/47	45/50
	RXBH-1724A18C	12.8/17.0	3/60	3-5.68	SINGLE	35.5/41.0	2.5	48.55	50/60
	RXBH-17A07D	7.2	3/60	2-3.6	SINGLE	8.7	1.4	13	15
	RXBH-17A10D	9.6	3/60	3-3.2	SINGLE	11.6	1.4	17	20
	RXBH-17A15D	14.4	3/60	3-4.8	SINGLE	17.3	1.4	24	25
RXBH-17A18D	17	3/60	3-5.68	SINGLE	20.4	1.4	28	30	
4221/ 4821 4824	RXBH-1724?05J	3.6/4.8	1/60	1 - 4.8	SINGLE	17.3/20.0	5.2	29/32	30/35
	RXBH-1724?07J	5.4/7.2	1/60	2 - 3.6	SINGLE	26.0/30.0	5.2	39/44	40/45
	RXBH-1724?10J	7.2/9.6	1/60	2 - 4.8	SINGLE	34.6/40.0	5.2	50/57	50/60
	RXBH-1724A15J	10.8/14.4	1/60	3-4.8	SINGLE	51.9/60.0	5.2	72/82	80/90
	RXBH-1724A15J	3.6/4.8	1/60	1 - 4.8	MULTIPLE CKT 1	17.3/20.0	5.2	29/32	30/35
		7.2/9.6	1/60	2 - 4.8	MULTIPLE CKT 2	34.6/40.0	0.0	44/50	45/50
	RXBH-1724A18J	12.8/17	1/60	3-5.68	SINGLE	61.6/70.8	5.2	84/95	90/100
	RXBH-1724A18J	4.3/5.7	1/60	1 - 5.68	MULTIPLE CKT 1	20.5/23.6	5.2	33/36	35/40
		8.7/11.3	1/60	2 - 5.86	MULTIPLE CKT 2	41.1/47.2	0.0	52/59	60/60
	RXBH-24A20J	14.4/19.2	1/60	4-4.8	SINGLE	69.2/80	5.2	93/107	100/110
	RXBH-24A20J	7.2/9.6	1/60	2 - 4.8	MULTIPLE CKT 1	34.6/40.0	5.2	50/57	50/60
		7.2/9.6	1/60	2 - 4.8	MULTIPLE CKT 2	34.6/40.0	0.0	44/50	45/50
	RXBH-24A25J (4-ton only)	18.0/24.0	1/60	6-4.0	SINGLE	86.4/99.9	5.2	115/132	125/150
	RXBH-24A25J	6.0/8.0	1/60	2-4.0	MULTIPLE CKT 1	28.8/33.3	5.2	43/49	45/50
		6.0/8.0	1/60	2-4.0	MULTIPLE CKT 2	28.8/33.3	0.0	36/42	40/45
		6.0/8.0	1/60	2-4.0	MULTIPLE CKT 3	28.8/33.3	0.0	36/42	40/45
	RXBH-1724A07C	5.4/7.2	3/60	3 - 2.4	SINGLE	15.0/17.3	5.2	26/29	30/30
	RXBH-1724A10C	7.2/9.6	3/60	3 - 3.2	SINGLE	20.0/23.1	5.2	32/36	35/40
	RXBH-1724A15C	10.8/14.4	3/60	3 - 4.8	SINGLE	30.0/34.6	5.2	44/50	45/50
	RXBH-1724A18C	12.8/17.0	3/60	3-2.84	SINGLE	35.6/41.0	5.2	51/58	60/60
	RXBH-1724A18C	4.3/5.7	3/60	3 - 2.84	MULTIPLE CKT 1	17.8/20.5	5.2	29/33	30/35
		8.7/11.3	3/60	3 - 2.84	MULTIPLE CKT 2	17.8/20.5	0.0	23/26	25/30
	RXBH-24A20C	7.2-9.6	3/60	3-3.2	SINGLE	40.0/46.2	5.2	57/65	60/70
	RXBH-24A20C	7.2/9.6	3/60	3 - 3.2	MULTIPLE CKT 1	20.0/23.1	5.2	32/36	35/40
		7.2/9.6	3/60	3 - 3.2	MULTIPLE CKT 2	20.0/23.1	0.0	25/29	25/30
	RXBH-24A25C (4-ton only)	18.0/24.0	3/60	6-4.0	SINGLE	50.0/57.8	5.2	69/79	70/80
	RXBH-24A25C (4-ton only)	9.0/12.0	3/60	3-4.0	MULTIPLE CKT 1	25.0/28.9	5.2	38/43	40/45
		9.0/12.0	3/60	3-4.0	MULTIPLE CKT 2	25.0/28.9	0.0	32/37	35/40
	RXBH-24A07D	7.2	3/60	2-3.6	SINGLE	8.7	2.2	14	15
	RXBH-24A10D	9.6	3/60	3-3.2	SINGLE	11.6	2.2	18	20
RXBH-24A15D	14.4	3/60	3-4.8	SINGLE	17.3	2.2	25	25	

- Supply circuit protective devices may be fuses or "HACR" type circuit breakers.
- Largest motor load is included in single circuit and multiple circuit 1.
- If non-standard fuse size is specified, use next size larger standard fuse size.
- J Voltage (230V) single phase air handler is designed to be used with single or three phase 230 volt electric heaters. In the case of connecting 3-phase power to the air handler terminal block without the heater, bring only two leads to the terminal block cap, insulate and fully secure the third lead.

[ ] Designates Metric Conversions

## Electrical Data – With Electric Heat (Cont.)

Installation of the U.L. Listed original equipment manufacturer provided heater kits listed in the following table is recommended for all auxiliary heating requirements.

Air Handler Model FH**TPS	Heater Model No.	Heater kW (208/240V) (480V)	PH/HZ	No. Elements kW Per	Type Supply Circuit Single Circuit Multiple	Circuit Amps.	Motor Ampacity	Minimum Circuit Ampacity	Maximum Circuit Protection
4221/ 4821/ 4824	RXBH-24A18D	17.0	3/60	3-5.68	SINGLE	20.4	2.2	29	30
	RXBH-24A20D	19.2	3/60	6-3.2	SINGLE	23.2	2.2	32	35
	RXBH-24A25D (4-ton only)	24.0	3/60	6-4.0	SINGLE	28.8	2.2	39	40
6024	RXBH-1724?05J	3.6/4.8	1/60	1 - 4.8	SINGLE	17.3/20.0	5.2	29/32	30/35
	RXBH-1724?07J	5.4/7.2	1/60	2 - 3.6	SINGLE	26.0/30.0	5.2	39/44	40/45
	RXBH-1724?10J	7.2/9.6	1/60	2 - 4.8	SINGLE	34.6/40.0	5.2	50/57	50/60
	RXBH-1724A15J	10.8/14.4	1/60	3-4.8	SINGLE	51.9/60.0	5.2	72/82	80/90
	RXBH-1724A15J	3.6/4.8	1/60	1 - 4.8	MULTIPLE CKT 1	17.3/20.0	5.2	29/32	30/35
		7.2/9.6	1/60	2 - 4.8	MULTIPLE CKT 2	34.6/40.0	0.0	44/50	45/50
	RXBH-1724A18J	12.8/17	1/60	3-5.68	SINGLE	61.6/70.8	5.2	84/95	90/100
	RXBH-1724A18J	4.3/5.7	1/60	1 - 5.68	MULTIPLE CKT 1	20.5/23.6	5.2	33/36	35/40
		8.7/11.3	1/60	2 - 5.86	MULTIPLE CKT 2	41.1/47.2	0.0	52/59	60/60
	RXBH-24A20J	14.4/19.2	1/60	4-4.8	SINGLE	69.2/80	5.2	93/107	100/110
	RXBH-24A20J	7.2/9.6	1/60	2 - 4.8	MULTIPLE CKT 1	34.6/40.0	5.2	50/57	50/60
		7.2/9.6	1/60	2 - 4.8	MULTIPLE CKT 2	34.6/40.0	0.0	44/50	45/50
	RXBH-24A25J	18.0/24.0	1/60	6-4.0	SINGLE	86.4/99.9	5.2	115/132	125/150
	RXBH-24A25J	6.0/8.0	1/60	2-4.0	MULTIPLE CKT 1	28.8/33.3	5.2	43/49	45/50
		6.0/8.0	1/60	2-4.0	MULTIPLE CKT 2	28.8/33.3	0.0	36/42	40/45
		6.0/8.0	1/60	2-4.0	MULTIPLE CKT 3	28.8/33.3	0.0	36/42	40/45
	RXBH-24A30J	21.6/28.8	1/60	6-4.8	SINGLE	103.8/120	5.2	137/157	150/175
	RXBH-24A30J	7.2/9.6	1/60	2-4.8	MULTIPLE CKT 1	34.6/40.0	5.2	50/57	50/60
		7.2/9.6	1/60	2-4.8	MULTIPLE CKT 2	34.6/40.0	0.0	44/50	45/50
		7.2/9.6	1/60	2-4.8	MULTIPLE CKT 3	34.6/40.0	0.0	44/50	45/50
	RXBH-1724A07C	5.4/7.2	3/60	3 - 2.4	SINGLE	15.0/17.3	5.2	26/29	30/30
	RXBH-1724A10C	7.2/9.6	3/60	3 - 3.2	SINGLE	20.0/23.1	5.2	32/36	35/40
	RXBH-1724A15C	10.8/14.4	3/60	3 - 4.8	SINGLE	30.0/34.6	5.2	44/50	45/50
	RXBH-1724A18C	12.8/17.0	3/60	3-2.84	SINGLE	35.6/41.0	5.2	51/58	60/60
	RXBH-1724A18C	6.4/8.5	3/60	3 - 2.84	MULTIPLE CKT 1	17.8/20.5	5.2	29/33	30/35
		6.4/8.5	3/60	3 - 2.84	MULTIPLE CKT 2	17.8/20.5	0.0	23/26	25/30
	RXBH-24A20C	7.2-9.6	3/60	3-3.2	SINGLE	40.0/46.2	5.2	57/65	60/70
	RXBH-24A20C	7.2/9.6	3/60	3 - 3.2	MULTIPLE CKT 1	20.0/23.1	5.2	32/36	35/40
		7.2/9.6	3/60	3 - 3.2	MULTIPLE CKT 2	20.0/23.1	0.0	25/29	25/30
	RXBH-24A25C	18.0/24.0	3/60	6-4.0	SINGLE	50.0/57.8	5.2	69/79	70/80
	RXBH-24A25C	9.0/12.0	3/60	3-4.0	MULTIPLE CKT 1	25.0/28.9	5.2	38/43	40/45
		9.0/12.0	3/60	3-4.0	MULTIPLE CKT 2	25.0/28.9	0.0	32/37	35/40
	RXBH-24A07D	7.2	3/60	2-3.6	SINGLE	8.7	2.2	14	15
RXBH-24A10D	9.6	3/60	3-3.2	SINGLE	11.6	2.2	18	20	
RXBH-24A15D	14.4	3/60	3-4.8	SINGLE	17.3	2.2	25	25	
RXBH-24A18D	17.0	3/60	3-5.68	SINGLE	20.4	2.2	29	30	
RXBH-24A20D	19.2	3/60	6-3.2	SINGLE	23.2	2.2	32	35	
RXBH-24A25D	24.0	3/60	6-4.0	SINGLE	28.8	2.2	39	40	
RXBH-24A30D	28.8	3/60	6-4.8	SINGLE	34.6	2.2	46	50	

- Supply circuit protective devices may be fuses or "HACR" type circuit breakers.
- Largest motor load is included in single circuit and multiple circuit 1.
- If non-standard fuse size is specified, use next size larger standard fuse size.
- J Voltage (230V) single phase air handler is designed to be used with single or three phase 230 volt electric heaters. In the case of connecting 3-phase power to the air handler terminal block without the heater, bring only two leads to the terminal block cap, insulate and fully secure the third lead.

[ ] Designates Metric Conversions

## Electrical Wiring

### Power Wiring

- Field wiring must comply with the National Electrical Code (C.E.C. in Canada) and any applicable local ordinance.
- Supply wiring must be 75°C minimum copper conductors only.
- See electrical data for product Ampacity rating and Circuit Protector requirement.

## Accessories

### • Combustible Floor Base RXHB-

Model Cabinet Size	Combustible Floor Base Model Number
17	RXHB-17
21	RXHB-21
24	RXHB-24

- **Jumper Bar Kit 3 Ckt. to 1 Ckt. RXBJ-A31** is used to convert single phase multiple three circuit units to a single supply circuit. Kit includes cover and screw for line side terminals.
- **Jumper Bar Kit 2 Ckt. to 1 Ckt. RXBJ-A21** is used to convert single phase multiple two circuit units to a single supply circuit. Kit includes cover and screw for line side terminals.
- **Note:** No jumper bar kit is available to convert three phase multiple two circuit units to a single supply circuit.

### • Auxiliary Horizontal Overflow Pan Accessory RXBM-

Nominal Cooling Capacity-Tons	Auxiliary Horizontal Overflow Pan Accessory Model Number
1 <sup>1</sup> / <sub>2</sub> - 3	RXBM-AC48
3 <sup>1</sup> / <sub>2</sub> - 5	RXBM-AC61

### • External Filter Rack RXHF-B17, B21, B24

Model Cabinet Size	Filter Size In. [mm]	Part Number*	A	B
17	16 x 20 [406 x 508]	RXHF-B17	16.90	20.77
21	20 x 20 [508 x 508]	RXHF-B21	20.40	20.77
24	25 x 20 [635 x 508]	RXHF-B24	25.00	21.04

\*Accommodates 1" filter

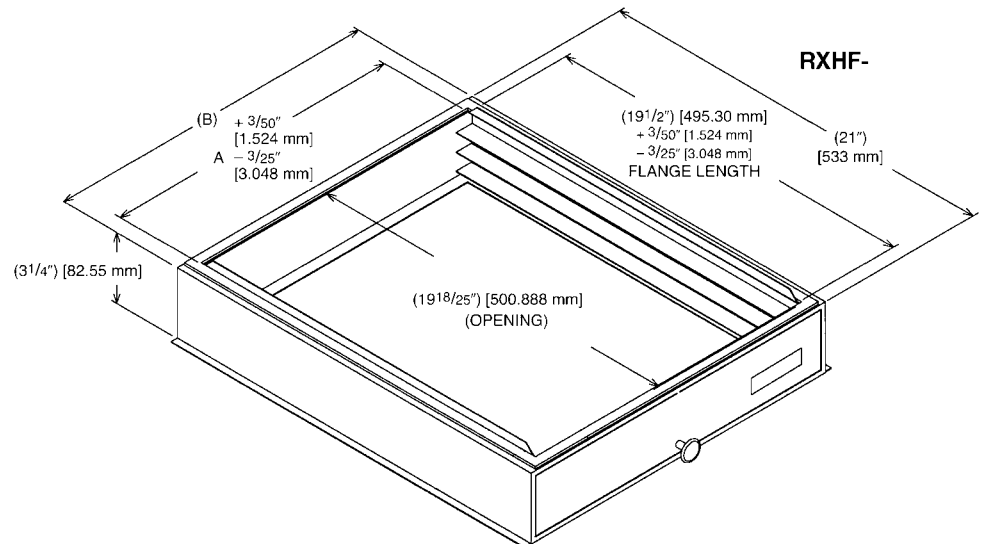
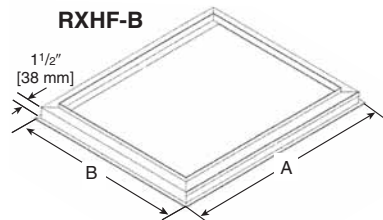

### Grounding

- This product must be sufficiently grounded in accordance with National Electrical Code (C.E.C. in Canada) and any applicable local ordinance.
- A grounding lug is provided.

### • Auxiliary Electric Heater Kits RXBH-

Heater Kits include circuit breakers which meet UL and cUL requirements for service disconnect. See the Electric Heat Electrical Data in this specification sheet for specific Heater Kit Model numbers.

### • Horizontal Adapter Kit RXHH-

This horizontal adapter kit is used to convert Upflow/Downflow only models to horizontal flow. See the following table to order proper horizontal adapter kit.

Coil Model	Horizontal Adapter Kit Model Number (Single Qty.)	Horizontal Adapter Kit Model Number (10-Pack Qty.)
2414	RXHH-A01	RXHH-A01 x 10
2417	RXHH-A02	RXHH-A02 x 10
3617/3621	RXHH-A03	RXHH-A03 x 10
3821/4821/4824	RXHH-A04	RXHH-A04 x 10
6024	RXHH-A05	RXHH-A05 x 10

### • External Filter Base RXHF-

Model Cabinet Size	Filter Size In. [mm]	Part Number*	A	B
17	16 x 20 [406 x 508]	RXHF-17	15.70	17.5
21	20 x 20 [508 x 508]	RXHF-21	19.20	21.0
24	25 x 20 [635 x 508]	RXHF-24	22.70	25.5

\*Accommodates 1" or 2" filter

[ ] Designates Metric Conversions



**GENERAL TERMS OF LIMITED WARRANTY\***

*Fujitsu General America, Inc.* will furnish a replacement for any part of this product which fails in normal use and service within the applicable periods stated, in accordance with the terms of the limited warranty.

Conditional Parts (Registration Required) .....Ten (10) Years

**\*For complete details of the Limited and Conditional Warranties, including applicable terms and conditions, contact your local contractor or the Manufacturer for a copy of the product warranty certificate.**





---

**Before proceeding with installation, refer to installation instructions packaged with each model, as well as complying with all Federal, State, Provincial, and Local codes, regulations, and practices.**

---

*"In keeping with its policy of continuous progress and product improvement, the right is reserved to make changes without notice."*