

# DUST FREE® ACTIVE Total Home Air Purification

## Installation & Operation Manual

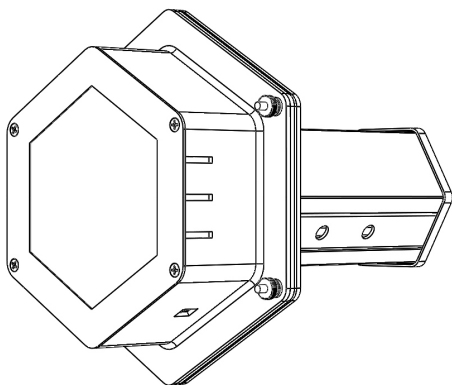

This manual covers the following models:

DF ACTIVE 6" - #13070

DF ACTIVE 12" - #13071

### GENERAL

This device is designed to be installed into an existing HVAC system for improved indoor air quality.

### BEFORE INSTALLING

- Read all instructions carefully. Failure to do so could damage the equipment or cause harm to yourself or others.
- Acknowledge all warnings.
- Only qualified technicians should perform the installation.

### INCLUDED INSIDE BOX

- Active Air Purifier System
- 24V power supply
- Core
- UV-C lamp
- 40VA transformer
- Mounting plate
- Mounting hardware
- Installation instructions

## SPECIFICATIONS

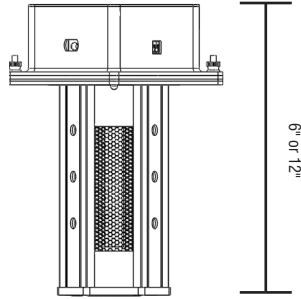
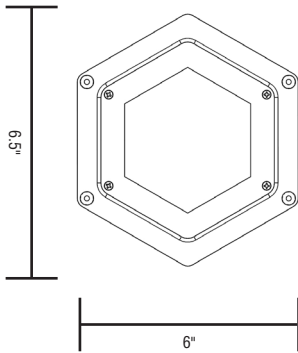

### DUST FREE® ACTIVE 6"

**Dimensions:**

Power Module: 6.5"H x 6"W x 6"L

Mounting Plate: 8"H x 8"W

**Electrical:** 24V (Expanded range ballast: 20V-32V), 50/60Hz, 1.4A. 3000V surge protection.

**Weight:** 3lbs

**Humidity:** Water resistant lamp.

**Lamp Life:** 18,000-hour.

**Warranty:** 7-year on power module. 2-year on lamp.

### DUST FREE® ACTIVE 12"

**Dimensions:**

Power Module: 6.5"H x 6"W x 12"L

Mounting Plate: 8"H x 8"W

**Electrical:** 24V (Expanded range ballast: 20V-32V), 50/60Hz, 1.4A. 3000V surge protection.

**Weight:** 3lbs

**Humidity:** Water resistant lamp.

**Lamp Life:** 18,000-hour.

**Warranty:** 7-year on power module. 2-year on lamp.



U.S. Patent Nos. 5,334,347, 5,817,276, 6,245,293, 6,267,924, 6,280,686, 6,313,470, 6,627,000, 6,539,727, 6,932,494, 6,550,257.



**NOTICE**

**Qualified Technicians Only.**

*This device must be installed in compliance with all national and local electrical and mechanical codes. Failure to do so will void Dust Free® Warranty.*

## UV INSTALLATION NOTES

This device is meant only to be installed in the duct portion of the HVAC system.

The duct work around the installation area should be clean and dry to insure proper adhesion of the gasket materials and any tape used.

An approximate 4" opening will need to be cut into the existing duct work to install the device properly.

## AIRFLOW ORIENTATION

Be sure to orient the device for proper airflow through the core. Proper airflow direction is indicated by an arrow on the tip of the core. (See Fig. 2)

## 24V ELECTRICAL REQUIREMENTS

Connect black and white wires to a dedicated 40VA transformer.

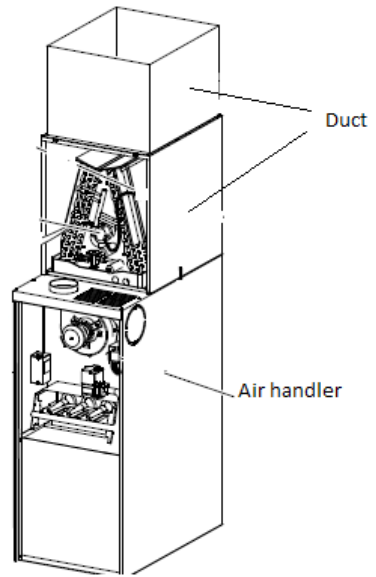

Fig. 1 HVAC system.

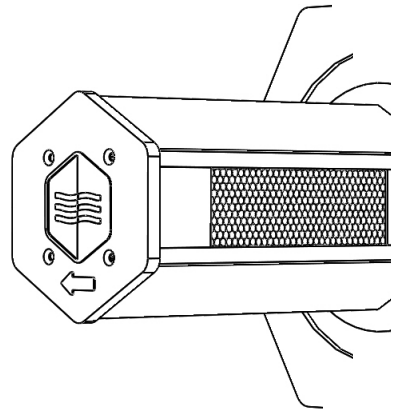

Fig. 2 Orient device in proper airflow direction as indicated.



### **WARNING**

**Electric Shock Hazard.**  
**Can cause injury or death.**

*Electrical wiring of the unit to the HVAC system should be done by a licensed HVAC technician or electrical installer.*



### **WARNING**

**UV Light Hazard.**  
**Can cause serious eye and skin damage.**

*Do not look at UV-C light. Wear UV-C eye and skin protection.*

## METAL DUCTWORK INSTALLATION

- Locate a suitable area of the duct for installation. Minimum 8" area.
- If needed, cut away insulation to expose metal duct.
- Mark location for 4" opening using the included mounting plate as a template.
- Cut opening for the device.
- Remove the backing from the mounting plate gasket, center mounting plate over opening, and press onto the duct. The adhesive gasket will hold the mounting plate in place.
- Secure the mounting plate using self-tapping screws.
- Insert device into opening and secure with knurled nuts.  
**Note: Be sure airflow will pass in the proper direction as indicated by the arrow on the top of the core. (See fig.2)**
- Connect to proper power and test operation. The operation indicator light on the face of the device should be on.

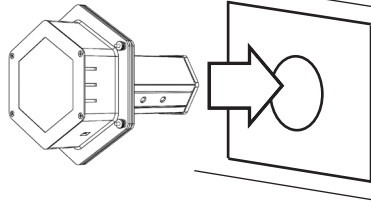

Fig. 3 Cut opening in duct, attach mounting plate, and install device.

## FIBERGLASS DUCTWORK NOTE

For fiberglass ductwork installations use 3" toggle bolts to attach mounting plate.

## MAINTENANCE/UV LAMP INDICATOR

For optimal performance, replace the device core and UV-C lamp every 2 years, even if the UV-C lamp appears to be operating normally.

The operation indicator on the face of the device should glow during normal operation. If the indicator does not glow and the unit has power, the device core should be replaced.

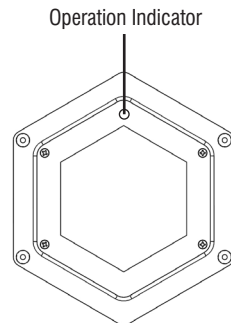

Fig. 4 Operation indicator.

**! WARNING**  
**Electric Shock Hazard.**  
 Can cause injury or death.  
 Electrical wiring of the unit to the HVAC system should be done by a licensed HVAC technician or electrical installer.

**! WARNING**  
**UV Light Hazard.**  
 Can cause serious eye and skin damage.  
 Do not look at UV-C light. Wear UV-C eye and skin protection

## CHANGING THE CORE OR UV-C LAMP

- Disconnect the device from power.
- Removed the knurled nuts securing the device and remove the device from the core.
- Remove the screws securing the core.
- Remove the core from the device and dispose of properly. **Note: If only changing the UV-C lamp, detach lamp from device and dispose of properly.**
- Secure the new core or new UV-C lamp to the device.
- Reverse the previous steps to return the device to operation.

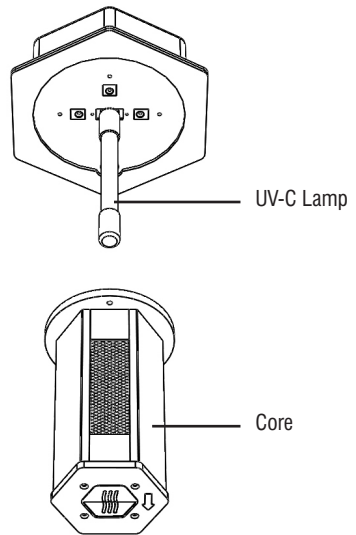

Fig. 5 Replace core and UV-C lamp every 2 years.

## DISPOSAL OF CORE/UV-C LAMP

Dispose of spent core and UV-C lamp at your local recycling center. You may also send your spent core and UV-C lamp, in the same container you received your replacement, to:

### Dust Free® Reclamation

1112 Industrial Drive  
 Royse City, TX 75189

**! WARNING**  
**Mercury Hazard. Do Not Break.**  
*UV-C lamp contains a small amount of Mercury. May cause redness or irritation. Manage in accordance with disposal laws. [www.lamprecycle.org](http://www.lamprecycle.org)*

**! WARNING**  
**Electric Shock Hazard.**  
**Can cause injury or death.**  
*Electrical wiring of the unit to the HVAC system should be done by a licensed HVAC technician or electrical installer.*

**! WARNING**  
**UV Light Hazard.**  
**Can cause serious eye and skin damage.**  
*Do not look at UV-C light. Wear UV-C eye and skin protection*

## WARRANTY

Dust Free LP warrants this DF Active air purifier to be free from defects in materials and workmanship under normal use and service, for a period of seven (7) years from the date of purchase. This warranty does not cover UV-C lamp(s), which carry a two (2) year warranty from the date of installation.

This warranty does not cover cosmetic damage, damage due to acts of God, damage as a result of handling or shipment, negligence, misuse, connection to improper voltage, improper maintenance, or abuse. This warranty is void if defect(s) result from failure to have this unit installed by a qualified, properly licensed, heating and air conditioning contractor in compliance with all local building and construction codes.

Dust Free LP's exclusive obligation under this warranty shall be to supply, without charge, a replacement for any covered component of the DF Active air purifier which is found to be defective within the parameters defined herein. Dust Free LP reserves the right to replace or repair the defective part or component.

DUST FREE LP SHALL NOT BE LIABLE FOR ANY LOSS OR DAMAGE OF ANY KIND, INCLUDING ANY INCIDENTAL OR CONSEQUENTIAL DAMAGES RESULTING, DIRECTLY OR INDIRECTLY, FROM ANY BREACH OF WARRANTY, EXPRESS OR IMPLIED, OR ANY OTHER FAILURE OF THIS PRODUCT. (Some states do not allow the exclusion or limitation of incidental or consequential damages, so this limitation may not apply to you.) THE WARRANTIES SET FORTH HEREIN ARE EXCLUSIVE AND DUST FREE LP EXPRESSLY DISCLAIMS ALL OTHER WARRANTIES, WHETHER WRITTEN OR ORAL, IMPLIED OR STATUTORY, INCLUDING BUT NOT LIMITED TO ANY WARRANTIES OF MERCHANTABILITY, WORKMANSHIP, OR FITNESS FOR A PARTICULAR USE. If the limited warranty is void due to failure to use a qualified contractor all disclaimers of implied warranties shall be effective upon installation.

How to make a warranty claim or have questions answered:

Should you have a warranty claim or questions about the warranty policy, contact the distributor or dealer from which you purchased the product. Proof of original purchase and proof of identity that the original purchasing party is filing the claim is required in order to initiate a warranty claim. Defective parts must be returned no later than thirty (30) days after the failure to the installing contractor together with the model number, serial number, and date of installation. All service and removal must be performed by a licensed HVAC contractor. You must pay shipping charges and all other costs of warranty service. Warranty is only valid the United States and Canada.

THIS WARRANTY SHALL NOT OBLIGATE THE MANUFACTURER FOR ANY LABOR COSTS AND SHALL NOT APPLY TO DEFECTS IN WORKMANSHIP OR MATERIALS FURNISHED BY THE INSTALLING CONTRACTOR AS CONTRASTED TO DEFECTS IN THE GERMICIDAL LIGHT ITSELF.

NOTE: Do not return any products or parts to the factory without a factory issued Return Authorization number issued by the Dust Free LP customer service department.

In the event you have any questions concerning the use and care of this product or this warranty which have not been answered to your satisfaction by the distributor or dealer, please call or write the factory.

Dust Free®

PO Box 519, 1112 Industrial Park Drive  
Royse City, TX 75189  
1-972-635-9564  
[www.dustfree.com](http://www.dustfree.com)